

**THE REGISTRY OF PATENTS
SINGAPORE**

**THE PATENTS ACT
(CHAPTER 221)**

CERTIFICATE OF GRANT OF PATENT

In accordance with section 35 of the Patents Act, it is hereby certified that a patent having the following P-No. 42557[WO 96/17956] had been granted in respect of an invention having the following particulars:

Title : METHOD OF DETECTION OF NUCLEIC ACIDS
WITH A SPECIFIC SEQUENCE COMPOSITION

Application No. : 9702681-9

Date of Filing : 07 December 1995

Priority Data : 09 December 1994 - PATENT APPLICATION NO.
08/353,476(UNITED STATES OF AMERICA)

Name of Inventor(s) : WEININGER, SUSAN; WEININGER, ARTHUR, M

Name(s)
and Address(es) of
Proprietor(s) of Patent : THE GENE POOL, INC
SUITE 392, 300 QUEEN ANNE AVENUE NORTH,
SEATTLE, WASHINGTON 98109-4599,
WASHINGTON, UNITED STATES OF AMERICA

Date of Grant : 19 December 1997

Dated this 19th day of December 1997.

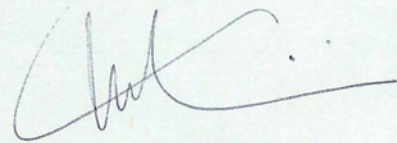

Anne Loo Voon Voon (Ms)
Acting Registrar of Patents,
Singapore.





9702681-9-

INTERNATIONAL APPLICATION PUBLISHED UNDER THE PATENT COOPERATION TREATY (PCT)

<p>(51) International Patent Classification ⁶ : C12Q 1/68</p>	<p>A2</p>	<p>(11) International Publication Number: WO 96/17956 (43) International Publication Date: 13 June 1996 (13.06.96)</p>
--	-----------	---

(21) International Application Number: PCT/US95/15944
 (22) International Filing Date: 7 December 1995 (07.12.95)
 (30) Priority Data:
 08/353,476 9 December 1994 (09.12.94) US
 (71) Applicant (for all designated States except US): THE GENE POOL, INC. [US/US]; Suite 392, 300 Queen Anne Avenue North, Seattle, WA 98109-4599 (US).
 (72) Inventors; and
 (75) Inventors/Applicants (for US only): WEININGER, Susan [US/US]; Suite 392, 300 Queen Anne Avenue North, Seattle, WA 98109-4599 (US). WEININGER, Arthur, M. [US/US]; Suite 392, 300 Queen Anne Avenue North, Seattle, WA 98109-4599 (US).
 (74) Agents: BENCEN, Gerard, H. et al.; Saliwanchik & Saliwanchik, Suite A-1, 2421 N.W. 41st Street, Gainesville, FL 32606-6669 (US).

(81) Designated States: AL, AM, AU, BB, BG, BR, BY, CA, CN, CZ, EE, FI, GE, HU, IS, JP, KG, KP, KR, KZ, LK, LR, LT, LV, MD, MG, MK, MN, MX, NO, NZ, PL, RO, RU, SG, SI, SK, TJ, TM, TT, UA, US, UZ, VN, European patent (AT, BE, CH, DE, DK, ES, FR, GB, GR, IE, IT, LU, MC, NL, PT, SE), OAPI patent (BF, BJ, CF, CG, CI, CM, GA, GN, ML, MR, NE, SN, TD, TG), ARIPO patent (KE, LS, MW, SD, SZ, UG).

Published

Without international search report and to be republished upon receipt of that report.

(54) Title: METHOD OF DETECTION OF NUCLEIC ACIDS WITH A SPECIFIC SEQUENCE COMPOSITION

(57) Abstract

This invention is a novel method for detecting and localizing specific nucleic acid sequences in a sample with a high degree of sensitivity and specificity. The method and novel compositions used in the method involve the use of Probe Nucleic Acids, the production of nucleic acid binding regions and the use of nucleic acid Target Binding Assemblies to detect and localize specific Target Nucleic Acids. The detection and localization of the Target Nucleic Acid is accomplished even in the presence of nucleic acids which have similar sequences. The method provides for a high degree of amplification of the signal produced by each specific binding event. In particular, methods and compositions are presented for the detection of HIV and HPV nucleic acid in samples. These methods and compositions find use in diagnosis of disease, genetic monitoring, forensics, and analysis of nucleic acid mixtures. Some of the novel compositions used in the detection method are useful in preventing or treating pathogenic conditions.

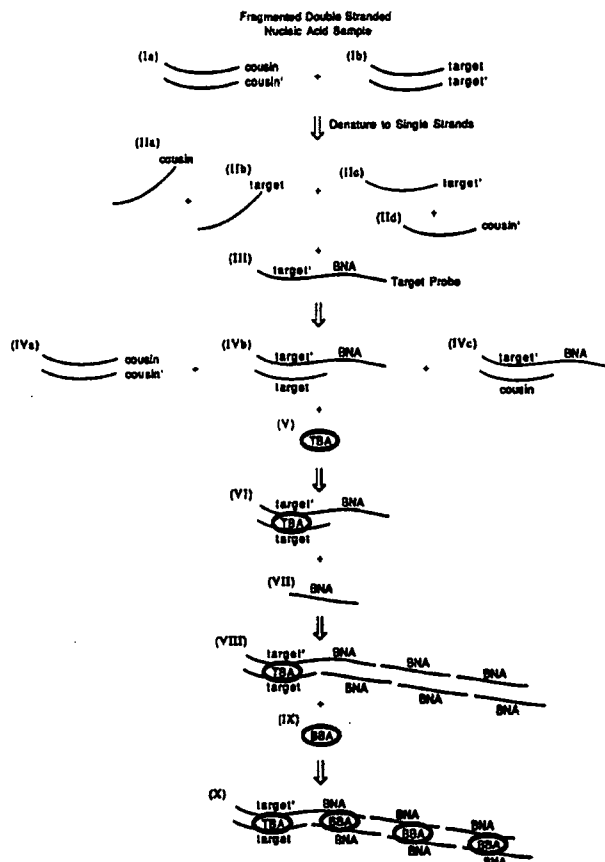

FOR THE PURPOSES OF INFORMATION ONLY

Codes used to identify States party to the PCT on the front pages of pamphlets publishing international applications under the PCT.

AT	Austria	GB	United Kingdom	MR	Mauritania
AU	Australia	GE	Georgia	MW	Malawi
BB	Barbados	GN	Guinea	NE	Niger
BE	Belgium	GR	Greece	NL	Netherlands
BF	Burkina Faso	HU	Hungary	NO	Norway
BG	Bulgaria	IE	Ireland	NZ	New Zealand
BJ	Benin	IT	Italy	PL	Poland
BR	Brazil	JP	Japan	PT	Portugal
BY	Belarus	KE	Kenya	RO	Romania
CA	Canada	KG	Kyrgystan	RU	Russian Federation
CF	Central African Republic	KP	Democratic People's Republic of Korea	SD	Sudan
CG	Congo	KR	Republic of Korea	SE	Sweden
CH	Switzerland	KZ	Kazakhstan	SI	Slovenia
CI	Côte d'Ivoire	LI	Liechtenstein	SK	Slovakia
CM	Cameroon	LK	Sri Lanka	SN	Senegal
CN	China	LU	Luxembourg	TD	Chad
CS	Czechoslovakia	LV	Latvia	TG	Togo
CZ	Czech Republic	MC	Monaco	TJ	Tajikistan
DE	Germany	MD	Republic of Moldova	TT	Trinidad and Tobago
DK	Denmark	MG	Madagascar	UA	Ukraine
ES	Spain	ML	Mali	US	United States of America
FI	Finland	MN	Mongolia	UZ	Uzbekistan
FR	France			VN	Viet Nam
GA	Gabon				

3702681-9

DESCRIPTIONMETHOD OF DETECTION OF NUCLEIC ACIDS
WITH A SPECIFIC SEQUENCE COMPOSITION

5

Background of the Invention1. Field of the Invention

10 This invention provides a method and compositions for use in binding, detecting, and amplifying the detection of specific Target Nucleic Acid sequences in a sample with fidelity and accuracy, even in the presence of closely related but different nucleic acids. The binding may involve the chaperoning and assembly of specific molecules into Target Binding Assemblies which specifically bind Target Binding Regions formed by the hybridization of Probe Nucleic Acids and Target Nucleic Acid sequences. The amplifying may involve the chaperoning and/or assembly of specific molecules into Booster Binding Assemblies which specifically bind Booster Binding Regions formed by the hybridization of Booster Nucleic Acids with Probe Nucleic Acids, Target Nucleic Acids, or other Booster Nucleic Acids. A method, and compositions, involving Hairpin Nucleic Acids is also provided to enable control of the size of specifically or non-specifically elongated Booster Nucleic Acids and Booster Binding Assemblies used in the amplification. The detecting involves providing one or more detectable labels, including radioactive, light- or fluorescent-emitting, enzymatic, or other detectable or signal-generating molecules, in association with the Probe Nucleic Acid, the Target Binding Assembly, the Booster Nucleic Acid, the Booster Binding Assembly, or the Hairpin Nucleic Acid. A method is presented for isolating nucleic acid fragments from an organism which has TBA component binding sites in order to create a probe nucleic acid and a TBA which is unique for that fragment and/or organism. Therapeutic and prophylactic uses of the Target Binding Assemblies and compositions for such use are also provided.

25

2. Background and Description of Related Art

30

There are an increasing number of cases in which it is important to be able to detect nucleic acids containing a specific sequence, hereinafter named Target Nucleic Acids (TNAs), in a sample. It is desirable to be able to detect the TNAs with the smallest number of processing steps, with the simplest components and to the exclusion of other similar but different nucleic acids, hereinafter named Cousin Nucleic Acids (CNAs). It is desirable to be able to detect specific TNAs to the

exclusion of any and all CNAs in the detection sample without the necessity of amplification or other post-detection processing.

5 There are numerous methods which use immobilized or tagged nucleic acids as probes for TNAs. However, using known methods, it is difficult to discriminate between a TNA bound to the Probe Nucleic Acid (PNA) as opposed to a CNA bound to the PNA. For example, one or more base mismatches between the PNA and a CNA can still result in a CNA-PNA hybridization which is almost indistinguishable from a TNA-PNA hybridization. Thus, hybridization alone is not an optimal indicator that a PNA has hybridized to a unique TNA.

10 There are many situations in which a PNA would be used to try to determine whether a TNA was present in a sample which may contain CNAs. Hybridization of the PNA to any CNA in this situation would limit the diagnostic value that the PNA might have for the detection of a TNA, absent additional verification. Furthermore, it is desirable to be able to detect and localize TNAs with low copy numbers in samples which may contain many copies of CNAs, without the necessity of creating additional copies of the TNA. It would also be desirable to be able to confirm the presence of CNAs, independent of the TNAs, without the necessity of separating the CNAs and TNAs in the sample.

15 Furthermore, it would be desirable to be able to amplify the signal of even a low frequency hybridization of a particular TNA-PNA. For this purpose, a method of polymerizing multiple copies of a label, hereinafter referred to as a Booster Nucleic Acid (BNA) onto the TNA-PNA would be desirable.

20 The instant invention provides methods and compositions for achieving the foregoing desired objectives. As revealed by the following review, the instant compositions and methods have not been reported or suggested in the art. A general and comprehensive review of the state of art of nucleic acid detection is provided in Keller, H., M.M. Manak (1989) *DNA Probes*, Stockton Press.

25 A method has been reported for detecting base pair mismatches by chemical means in order to determine whether a PNA has hybridized to a CNA rather than to a TNA. In U.S. Patent No. 4,794,075 to Ford *et al.*, a method for distinguishing fragments of DNA which contain single base mismatches from their perfectly paired homologs is discussed. Single stranded regions within a duplex fragment are modified with carbodiimide, which reacts with unpaired guanine (G) and thymine (T) residues in DNA. Linear duplex DNA molecules do not react, while DNA molecules with single base mismatches react quantitatively. Following reaction with carbodiimide, the DNA molecules are fractionated on high percentage polyacrylamide gels such that modified and unmodified fragments can be distinguished. Ford *et al.* applied this technique in order to locate and purify DNA sequence differences responsible for phenotype variation and inherited disease.

30

Although this method is useful for following variations in genetic material, it has a large number of steps, it requires costly components, and it does not offer a direct means of determining whether a PNA has hybridized to the TNA exclusive of CNAs in the sample.

5 There have been some attempts to assure that at least a portion of the hybridization between the PNA and another nucleic acid is complementary. One method involves the monitoring of transcription products which are produced if the PNA hybridizes to a nucleic acid sufficiently to be transcribed from a promoter site contained in the probe. U.S. Patent No. 5,215,899 to Dattagupta discloses how specific nucleic acid sequences are amplified through the use of a hairpin probe which, upon hybridization with and ligation to a target sequence, is capable of being transcribed. The probe
10 comprises a single stranded self-complementary sequence which, under hybridizing conditions, forms a hairpin structure having a functional promoter region, and further comprises a single stranded probe sequence extending from the 3' end of the hairpin sequence. Upon hybridization with a target sequence complementary to the probe sequence and ligation of the 3' end of the hybridized target sequence to the 5' end of the hairpin probe, the target sequence is rendered transcribable in the presence of a suitable RNA polymerase and appropriate ribonucleoside triphosphates (rNTPs).
15 Amplification is accomplished by hybridizing the desired TNA sequence with the probe, ligating the TNA to the PNA, adding the RNA polymerase and the rNTPs to the separated hybrids, and allowing transcription to proceed until a desired amount of RNA transcription product has accumulated. That method generally and specifically involves the use of hairpin DNA formed with a single stranded unpaired end to anneal a target sequence. When the target sequence is bound, the production of
20 RNA transcription products is enabled. Thus, the method involves the detection of secondary transcription products rather than the use of a nucleic acid binding assembly to directly immobilize and/or localize a target sequence. A CNA could easily bind to the probe, and the lack of complementarity would not necessarily interfere with the formation of a CNA-PNA hybrid which could then support the production of unwanted transcription products.
25

A CNA bound to the PNA might be detected if the lack of complementarity interferes with the susceptibility of the hybrid CNA-PNA pair to be cut by a restriction endonuclease. In U.S. Patent No. 5,118,605 to Urdea and U.S. Patent No. 4,775,619 to Urdea, novel methods for assaying a nucleic acid analyte were provided, which employ polynucleotides having oligonucleotide
30 sequences substantially homologous to a sequence of interest in the analyte, where the presence or absence of hybridization at a predetermined stringency provides for the release of a label from a support. Various techniques are employed for binding a label to a support, whereupon cleavage of either a single or double strand, a label may be released from a support, and the release of the label can be detected as indicative of the presence of a particular polynucleotide sequence in a sample.

However, this technique has the shortcoming that a CNA-PNA pair could be cut by the restriction endonuclease, even if there is a mismatch, so long as the mismatch was outside of the endonuclease recognition region. This would lead to failure of the assay to identify a CNA-PNA hybrid.

Another method uses a branched DNA probe to detect nucleic acids. U.S. Patent No. 5,124,246 to Urdea *et al.* discloses linear or branched oligonucleotide multimers useful as amplifiers in biochemical assays which comprise (1) at least one first single-stranded oligonucleotide unit (PNA) that is complementary to a single-stranded oligonucleotide sequence of interest (TNA), and (2) a multiplicity of second single-stranded, oligonucleotide units that are complementary to a single-stranded labeled oligonucleotide. Although amplified sandwich nucleic acid hybridizations and immunoassays using the multimers are described, the method has the limitation that PNA-CNA hybridization could occur and would result in production of unwanted signal.

In addition to methods for identification of TNAs, methods have been disclosed for the amplification of this DNA. In U.S. Patent No. 5,200,314 to Urdea, an analyte polynucleotide strand having an analyte sequence (TNA) is detected within a sample containing polynucleotides by contacting the analyte polynucleotide with a capture probe (PNA) under hybridizing conditions, where the capture probe has a first binding partner specific for the TNA, and a second binding sequence specific for a solid phase third binding partner. The resulting duplex is then immobilized by specific binding between the binding partners, and non-bound polynucleotides are separated from the bound species. The analyte polynucleotide is optionally displaced from the solid phase, then amplified by PCR. The PCR primers each have a polynucleotide region capable of hybridizing to a region of the analyte polynucleotide, and at least one of the primers further has an additional binding partner capable of binding a solid-phase binding partner. The amplified product is then separated from the reaction mixture by specific binding between the binding partners, and the amplified product is detected. Although it is possible to confirm (by PCR) that a particular nucleic acid has hybridized with the PNA, confirmation is expensive and involves multiple steps.

As for reports that involve the interaction of a double stranded nucleic acid and a DNA-binding protein, a method has been described whereby a sequence of immobilized DNA which contains binding sites for a single protein is used to purify that protein. U.S. Patent No. 5,122,600 to Kawaguchi *et al.* discloses a DNA-immobilized microsphere comprising DNA chains having base sequences which specifically bind a particular protein, and a carrier having a particle size of not more than 50 μm and not less than 0.01 μm which does not adsorb any protein, said carrier and said DNA chains being bound to each other by a chemical bond, and a process for purifying a protein using said microsphere. As this is a purification method for a protein, it does not disclose a method of detection

of a TNA nor a method whereby more than one protein is bound to a double stranded nucleic acid for the purposes of detection and localization of specific TNA sequences.

In EP 0 453 301, a method for detecting a polynucleotide target sequence in a sample was described wherein sequences in a TNA are detected by hybridizing a first and a second PNA to the TNA. Each of said first and second PNAs contained a pre-formed duplex sequence, or a duplex that is formed through chain extension, capable of binding a nucleotide sequence specific binding protein. A method for binding a nucleotide specific binding protein to a duplex formed between a TNA and a PNA only upon formation of a duplex between the PNA and TNA is neither disclosed nor suggested.

In U.S. Patent No. 4,556,643, a method was disclosed for the non-radioactive detection of specific nucleotide sequences in a sample which involved hybridization of a probe containing DNA binding protein specific sequences. However, this disclosure neither taught nor suggested a method for binding a nucleotide specific binding protein to a duplex formed between a TNA and a PNA only upon formation of a duplex between sequences present in the PNA and sequences present in the TNA.

Brief Summary of the Invention

Disclosed are methods by which specific Target Nucleic Acid (TNA) sequences are detected through the use of Probe Nucleic Acids (PNAs) which, upon hybridization with TNAs, are capable of binding Target Binding Assemblies (TBAs). Each TBA binds at least one specific region of the PNA-TNA hybrid pair, the Target Binding Region (TBR). The TBA is comprised of one or more molecules, one or more of which can bind to TBR sequences in a specific and sequence or conformation dependent manner. The TBA may comprise one or more piloting sequences, called "PILOTS" or "Asymmetry Sequences," which assemble and constrain the nucleotide binding components of the TBA to specific geometries. The PILOTS act to assemble specific nucleic acid recognition units or other pilots to which specific nucleic acid recognition units are attached into the TBAs in a predetermined fashion. The TBA may also contain one or more molecules which anchor or localize the TBA. Novel TBAs having unique discriminating characteristics which surprisingly render the TBAs useful not only as diagnostic tools but also as prophylactic or therapeutic compounds, are also disclosed. Disclosed are methods and compositions for utilization of the PNAs, TBRs, TBAs, and TBA PILOTS, including their utilization as components of diagnostic and forensic test kits and the utilization of the novel TBAs as prophylactic or therapeutic agents.

The PNAs, in addition to TNA-specific sequences, may also contain one or more sequences, 1/2 BBRs, capable of hybridizing with complementary 1/2 BBRs in Booster Nucleic Acids (BNAs). Through hybridization of added BNAs to the starter 1/2 BBRs present in the PNAs, extensions of the PNAs are made in the form of PNA-BNA and then BNA-BNA hybrids. These
5 extensions can contain one or more Booster Binding Regions (BBRs). Each BBR is capable of binding a Booster Binding Assembly (BBA). The BBA is comprised of molecules, one or more of which can bind to a BBR in a specific and sequence or conformation dependent manner. The BBA may comprise one or more piloting sequences, called "PILOTS" or "Asymmetry Sequences," which assemble and constrain the nucleotide binding components of the TBA to specific geometries. The
10 PILOTS act to assemble specific nucleic acid recognition units or other pilots to which specific nucleic acid recognition units are attached into the BBAs in a predetermined fashion. The BBA may contain molecules which anchor or localize the BBA or which allow for detection of the bound BBAs and thereby of the TBA-TNA-PNA complexes to which they, in turn, are bound. Disclosed are methods and compositions for utilization of the 1/2 BBRs, BNAs, BBRs, BBAs, and BBA PILOTS,
15 including their utilization as components of diagnostic and forensic test kits.

Methods and compositions are disclosed for the use of Hairpin Nucleic Acids (HNAs) as capping structures. The HNAs contain a self-hybridizing region and a single stranded 1/2 BBR which, under hybridizing conditions, can hybridize directly to the 1/2 BBRs in the PNAs or the 1/2
20 BBRs in BNAs already bound to the PNAs, to terminate the extension of BNAs onto the PNA or onto other BNAs.

Methods and compositions are disclosed for test procedures and the production of a test kit containing PNAs, TBAs, TBRs, BNAs, BBRs, BBAs and HNAs for the detection, localization and differentiation of specific nucleic acid sequences, including nucleic acid sequences which are found
25 in human cells, in the Human Immunodeficiency Virus (HIV), Human Papillomavirus (HPV), and in other nucleic acid containing systems including viruses and bacteria.

Accordingly, it is an object of this invention to provide methods and compositions for use in binding, detecting, and amplifying the detection of specific Target Nucleic Acid sequences in a sample with fidelity and accuracy, even in the presence of closely related but different nucleic acid sequences.

30 Accordingly, it is an object of this invention to provide methods and compositions for the creation of Target Binding Assemblies which specifically bind Target Binding Regions formed by the hybridization of Probe Nucleic Acids and Target Nucleic Acid sequences.

Another object of this invention is to provide a method and compositions for the creation of Booster Binding Assemblies which specifically bind Booster Binding Regions formed by the

hybridization of Booster Nucleic Acid sequences with Probe Nucleic Acids, Booster Nucleic Acids and Hairpin Nucleic Acids.

Another object of this invention is to provide a method and compositions containing Hairpin Nucleic Acids which enable the control of the size of specifically or non-specifically elongated
5 Booster Nucleic Acids and Booster Binding Assemblies used in amplification of PNA-TNA hybridization events.

Another object of this invention is to provide a method and compositions for use in the selection, assembly and or chaperoning of specific molecules, each with nucleic acid binding discriminating capabilities, into Target and Booster Binding Assemblies.

10 Another object of this invention is to provide a method and compositions for use in amplifying the detection of Target Binding assemblies bound to Target Binding Regions using Booster Binding Assemblies and Booster Nucleic Acids.

Another object of this invention is to provide a method and compositions which allow the use of one or more detectable labels, including but limited to radioactive labels, light emitting,
15 fluorescent, enzymatic or other signal generating molecules. These labels are used in association with Probe Nucleic Acids, Target Binding Assemblies, Booster Binding Assemblies, Booster Nucleic Acids or Hairpin Nucleic Acids.

Another object of this invention is to provide a method for isolating nucleic acid fragments from an organism which has TBA component binding sites in order to create Probe Nucleic Acids
20 and TBAs which are unique for that fragment or organism.

Brief Description of the Drawings

The following illustrations are contained in Figure 1: Figure 1-I is a PNA containing a 1/2 TBR, which is a single-stranded sequence which is complementary to a TNA and a 1/2 BBR
25 sequence. Figure 1-IIa is a TNA to which is added the components of Figure 1-I, and, under hybridizing conditions, binds the PNA to form the components of Figure 1-IIIa, a PNA-TNA hybrid containing at least one TBR. Figure 1-IVa is a BNA which is added to the components of Figure 1-IIIa and, under hybridizing conditions, binds the 1/2 BBR of Figure 1-IIIa to form a PNA-BNA hybrid containing a BBR shown in Figure 1-Va.

30 Figure 1-IIb is a BNA which is added the components of Figure 1-I, and which, under hybridizing conditions, binds the PNA to form the components of Figure 1-IIIb, a PNA-TNA hybrid containing a BBR. Figure 1-IVb is a TNA to which is added the components of Figure 1-IIIb and which, under hybridizing conditions, binds the 1/2 TBR of Figure 1-IIIb to form a PNA-BNA hybrid containing a TBR shown in Figure 1-Vb.

Figure 1-IIc is a HNA which is added to the components of Figure 1-I and which, under hybridizing conditions, binds the PNA to form the components of Figure 1-IIIc, a PNA-HNA hybrid containing a BBR. Figure 1-IVc is a TNA which is added to the components of Figure 1-IIIc and which, under hybridizing conditions, binds the 1/2 TBR of Figure 1-IIIc to form a PNA-BNA hybrid containing a BBR shown in Figure 1-Vc.

The hybrids which form the TBRs and BBRs are useful in the present invention. The PNAs and BNAs, as indicated in Figure 1, may contain no attached support and/or indicator (OSA), or an attached support or other means of localization, including, but not limited to, attachment to beads, polymers, and surfaces, and/or indicators.

Figure 2a is a diagram of strategies for polymerization of BNAs onto PNAs and capping by HNAs.

Figure 2b is a diagram of additional strategies for amplifying PNA-TNA signals via polymerization of BNAs and capping by HNAs.

Figure 3 is a diagram showing the use of BNAs containing multiple 1/2 BBRs per BNA.

Figure 4a is a diagram showing the binding of TBAs and BBAs to TBRs and BBRs, and the ability of the TBA to discriminate between TNAs and CNAs. According to this embodiment, if the TBA is immobilized, either on a bead, microtiter plate surface, or any other such surface, only complexes such as complex X would be retained and detected, while complexes such as complex XI would not.

Figure 4b is a diagram exemplifying events similar to those shown in Figure 4a but in a slightly different order of occurrence.

Figure 5 is a diagram exemplifying PNAs containing between one 1/2 TBR and no 1/2 BBR to PNAs containing up to five 1/2 TBRs and one 1/2 BBR. The (a) and (b) members of each numeral (I, II, III, IV, V) form a set which, upon hybridization to a TNA, provide TBRs either with ((a) members) or without ((b) members) an available 1/2 BBR for amplification via hybridization to BNAs having complementary 1/2 BBRs.

Figure 6a is a diagram exemplifying a particular TNA having two 1/2 TBRs which, upon binding an appropriate PNA, forms two closely associated TBRs capable of binding two TBAs. A 1/2 BBR is also provided for amplification.

Figure 6b is a diagram showing the same events as in Figure 6a except here, a double TBA is used so that discrimination between single TBRs that occur in normal cellular samples may be discriminated from abnormal, double TBRs.

Figure 6c is a diagram showing the same scenario as in Figure 6a except that here, five TBRs are identified in the TNA. Each TBR may be bound to a TBA same or different, and each

TBA may be differentially labeled, allowing for confirmation that all five sites are present in the TNA.

Figure 6d is a diagram of the same events as in Figure 6c except here, a double TBA is shown, extending what is shown in Figure 6b to the use of the double TBA. An example of the TNA shown in item II in Figures 6a, 6b, 6c and 6d is HIV single stranded DNA or RNA.

Figure 7 shows the HIV LTR as a TNA, and two PNAs, and a strategy for detection of the TNA using the PNAs.

Figure 8 is a schematic of one embodiment of the invention wherein a target binding assembly is used to bind a hybrid TNA-PNA, and booster binding assemblies are used to bind polymerized BNAs.

Figure 9 is a schematic of a modular TBA in which assembly sequences, linker sequences, and asymmetry sequences are used to chaperone desired nucleic acid recognition units together to form a TBA.

Figure 10 shows modular TBAs useful in detection of HIV-specific sequences.

Figure 11 shows modular TBAs useful in the detection of human papillomavirus sequences. Each unit of E2 is actually a dimer of the DNA binding portion of E2.

Figure 12a is a schematic of TNA fractionation and shift in mobility due to binding of a TBA.

Figure 12b is a schematic of TNA fractionation and enhanced shift in mobility due to binding of BBAs in addition to TBAs.

Figure 13 shows a detection strategy for deletion sequences; an example of use of this strategy is for a human papillomavirus integration assay.

Figure 14 shows assembly of higher order TBAs through use of nucleic acid recognition units, linker, assembly, and asymmetry sequences such that various Target Binding Assemblies specific to binding sites in the HIV LTR are formed.

Figure 15 shows assembly of higher order TBAs through use of DNA recognition units, linker, assembly, and asymmetry sequences such that various Target Binding Assemblies specific to binding sites in the HPV genome are formed.

Figure 16 shows the discrimination achieved by using a complex TBA and the ability of endogenous competitor target binding molecules to eliminate binding of the TBA to a cousin nucleic acid but not from the TNA which contains the appropriate orientation of more than one site recognized by the TBA.

Figure 17 shows the ability of a TBA to specifically be targeted to bind to sites of sequence mismatch and to preferentially bind those sites over cousin sites which do not contain all of the targeted mismatches.

5

Brief Description of the Sequences

SEQ ID NO. 1 corresponds to Figure 5-Ia-1 and shows the class I MHC NF-kB binding site.

SEQ ID NO. 2 corresponds to Figure 5 (Ia) and shows the B2-microglobulin NF-kB binding site.

10

SEQ ID NO. 3 corresponds to Figure 5 (Ia) and shows the kappa immunoglobulin NF-kB binding site.

SEQ ID NO. 4 corresponds to Figure 5 (Ia) and shows one of the HIV NF-kB binding sites.

SEQ ID NO. 5 corresponds to Figure 5 (Ia) and shows one of the HIV NF-kB binding sites.

SEQ ID NO. 6 corresponds to Figure 5 (Ia) and shows the c-myc NF-kB binding site.

15

SEQ ID NO. 7 corresponds to Figure 5 (IIa) and shows a double HIV NF-kB binding site.

SEQ ID NO. 8 corresponds to Figure 5 (IIa) and shows a double HIV NF-kB binding site.

SEQ ID NOS. 9-16 correspond to Figure 5 (IIa) and show a double binding site with one site being an HIV NF-kB binding site, and the other site being an HIV SP1 binding site.

SEQ ID NOS. 17-18 correspond to Figure 5 (IIa) and show a double HIV SP1 binding site.

20

SEQ ID NOS. 19-31 correspond to Figure 5 (IIIa) and show a double HIV NF-kB binding site and an HIV SP1 binding site.

SEQ ID NOS. 32-33 correspond to Figure 5 (IVa) and show a quadruple binding site where two sites are HIV NF-kB binding sites and two sites are HIV SP1 binding sites.

25

SEQ ID NO. 34 corresponds to Figure 5 VIa) and shows a quintuple binding site where two sites are HIV NF-kB binding sites and three sites are HIV SP1 binding sites.

SEQ ID NO. 35 is an example of a 1/2 BBR, in this case the OL1, OL2 and OL3 elements of the bacteriophage lambda left operator, including intervening sequences.

SEQ ID NO. 36 is an example of a 1/2 BBR, in this case the OR3, OR2 and OR1 elements of the bacteriophage lambda right operator, including intervening sequences.

30

SEQ ID NO. 37 is the HIV LTR.

SEQ ID NO. 38 is a PNA complementary to PNA of the HIV LTR.

SEQ ID NO. 39 is a PNA complementary to a different PNA of the HIV LTR than SEQ ID NO. 38.

SEQ ID NO. 40 is a PNA complementary to part of the HIV LTR and it also contains a 1/2 BBR and an overhang sequence for polymerizing BNAs onto the PNA.

SEQ ID NO. 41 is a BNA complementary to the SEQ ID NO. 40 1/2 BBR.

5 SEQ ID NO. 42 is a BNA that will polymerize onto the SEQ ID NO. 41 BNA and which, with SEQ ID NOS. 40 and 41, creates a *PsrI* recognition site.

SEQ ID NO. 43 is a BNA that is complementary to the SEQ ID NO. 42 BNA and which completes a *BamHI* recognition site.

SEQ ID NO. 44 is an HNA which has a *BamHI* recognition site that will hybridize with the *BamHI* recognition site created by SEQ ID NOS. 42 and 43 to the growing polymer.

10 SEQ ID NO. 45 is a second PNA which, like SEQ ID NO. 40, is complementary to part of the HIV LTR, but not to the same sequence as SEQ ID NO. 40. SEQ ID NO. 45 also encodes a 1/2 BBR and an overhang which will allow polymerization of BNAs starting with a *SphI* recognition site.

15 SEQ ID NOS. 46-62 are human papillomavirus (HPV) specific PNAs which, upon hybridization with HPV sequences, form TBRs which bind HPV DNA binding proteins.

SEQ ID NOS. 63-71 are NF-kB DNA recognition units for incorporation into TBAs.

SEQ ID NO. 72 is a nuclear localization sequence.

SEQ ID NO. 73 is a SP1 sequence recognition unit.

SEQ ID NO. 74 is a TATA binding protein recognition unit.

20 SEQ ID NOS. 75-84 are papillomavirus E2 DNA recognition units.

SEQ ID NOS. 85-92 are asymmetry sequences.

SEQ ID NO. 93 is an arabidopsis TATA binding protein recognition unit.

SEQ ID NO. 94 is an HPV-16-E2-1 DNA binding protein recognition unit.

SEQ ID NO. 95 is an HPV-16-E2-2 DNA binding protein recognition unit.

25 SEQ ID NO. 96 is an HPV-18-E2 DNA binding protein recognition unit.

SEQ ID NO. 97 is an HPV-33-E2 DNA binding protein recognition unit.

SEQ ID NO. 98 is a bovine papillomavirus E2 DNA binding protein recognition unit.

SEQ ID NOS. 99-102 are exemplary linker sequences.

SEQ ID NO. 103 is an exemplary nuclear localization signal sequence (NLS).



30 SEQ ID NOS. 104-108 are exemplary chaperone sequences.

SEQ ID NOS. 109-116 are exemplary assembled TBA sequences.

SEQ ID NO. 117 is a consensus NF-kB binding site.

SEQ ID NO. 118 is an HIV Tat amino acid sequence.

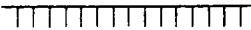
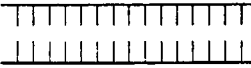
Abbreviations

		single stranded nucleic acid
		double-stranded nucleic acid
5		binding region on nucleic acid
10		no support or indicators, or solid support, or other means of localization, including, but not limited to, attachment to beads, polymers, and surfaces, or indicators = OSA
	BBA	booster binding assembly
	BBR	booster binding region
	BNA	booster nucleic acid
15	CNA	cousin nucleic acid
	1/2 BBR	single-stranded region which, when hybridized to the complementary sequence from an HNA or a BNA, can bind a BBA
	1/2 TBR	single-stranded region of the PNA which, when hybridized to the complementary sequence from a TNA, can bind a TBA
20	OSA	optional support or attachment, circle with box
	PNA	probe nucleic acid
	TBA	target binding assembly
	TBR	target binding region
	TNA	target nucleic acid
25	HNA	Hairpin Nucleic Acid

Definitions

It should also be understood from the disclosure which follows that when mention is made of such terms as target binding assemblies (TBAs), booster binding assemblies (BBAs), DNA binding proteins, nucleic acid binding proteins or RNA binding proteins, what is intended are compositions comprised of molecules which bind to DNA or RNA target nucleic acid sequences (TNAs) irrespective of the specificity of the category of binding molecules from which they are derived. Thus, for example, a TBA adapted to bind to human immunodeficiency virus sequences may be most similar to an NF-KB transcriptional factor which typically binds DNA sequences.

However, as used herein, it will be understood that the TBA may be adapted for optimal use to bind to RNA sequences of a particular sequence composition or conformation.

5 The fidelity of the detection method disclosed herein depends in large measure on the selective binding of TBAs and BBAs to particular nucleic acid motifs. It should be understood throughout this disclosure that the basis of TBA and BBA discrimination of TNAs from related sequences (cousin nucleic acids or CNAs) may be the formation of precise probe nucleic acid (PNA)-target nucleic acid (TNA) hybrid segments (PNA-TNA hybrids). However, the basis of discrimination may just as well be the formation of a particular conformation, and may not require the complete absence of mismatched-base pairing in the TNA-PNA hybrid. Accordingly, the basis of TBA or BBA operation should be understood throughout to depend on discrimination of any property unique to the TNA-PNA hybrid as opposed to any properties displayed by any PNA-CNA hybrids that may be formed in a test sample contacted with a given PNA.

Detailed Disclosure of the Invention

15 The present invention provides a method for specifically identifying a target nucleic acid (TNA) in a sample through the use of target binding assemblies (TBAs) which incorporate specific nucleic acid binding proteins. By using probe nucleic acids (PNAs) specific to a given TNA sequence, and a TBA which is specific to the duplex target binding region (TBR) formed upon formation of hybrid TNA-PNA sequences, a stable TBA-TNA-PNA complex is formed. By additionally providing specific amplifiable sequences in the PNA, in addition to sequences which specifically contribute to the formation of the TBR recognized by the TBA, the binding of the PNA to the TNA is detected and the detection amplified. For this purpose, any of a number of nucleic acid amplification systems, including polymerase chain reaction, or the use of branched DNA, each branch of which contains a detectable label, may be used. In particular, a novel method of amplification is described herein where the amplifiable portion of the PNA contains sequences onto which booster nucleic acids (BNAs) may be polymerized. Upon formation of each BNA-PNA hybrid, a booster binding region (BBR) is formed to which a booster binding assembly (BBA) binds specifically. If detectably labeled, the BBAs or BNAs provide essentially unlimited amplification of the original TNA-PNA binding event.

20
25
30 According to this invention, the TNA will be understood to include specific nucleic acid sequences. The TBA will be understood to be any molecular assembly which can specifically and tightly bind to a formed TNA-PNA hybrid. The TBA will contain one or more molecules whose sequences are sufficient to bind to the TBR. Nucleic acid binding domains which are known can either be used directly as components of the TBA or modified according to the teachings provided

herein. The most readily available molecules with such sequences are the DNA-binding domains of DNA-binding proteins. Specifically, many DNA or RNA binding proteins are known which can either be used directly as the known, unmodified protein, or the TBA may be a nucleic acid binding protein, modified according to the specific teachings provided herein. In the latter case, specific modifications that are desirable would include optimization of binding affinities, removal of unwanted activities (such as nuclease activity and reorganization of the TBA in the presence of other molecules with an affinity for components of the TBA), optimization of selectivity of a target sequence over closely related sequences, and optimization of stability.

Examples of DNA binding proteins which could be used according to this invention are the DNA-binding portions of the transcription factor NF-kB (p50 and p65), NF-IL6, NF-AT, rel, TBP, the papilloma virus' E2 protein, sp1, the repressors *cro* and CI from bacteriophage lambda, and like proteins are well known proteins whose DNA binding portion has been isolated, cloned, sequenced, and characterized. In addition, any other DNA-binding protein or portion of a protein that is necessary and sufficient to bind to a TBR hybrid or a BBR is included. This includes proteins or portions of wild-type proteins with altered DNA binding activity as well as protein created with altered DNA-binding specificity, such as the exchange of a DNA-binding recognition helix from one protein to another. In addition, proteins which exhibit nucleic acid binding and other nucleic acid functions, such as restriction endonucleases, could be used as the nucleic acid binding function. Proteins which bind to target regions in DNA-RNA hybrids as well as RNA-RNA hybrids are included. (See, for example, Shi 1995, DeStefano 1993, Zhu 1995, Gonzales 1994, Salazar 1993, Jaishree 1993, Wang 1992, Roberts 1992, Kainz 1992, Salazar 1993(b)). The binding assemblies may be constructed with the use of a molecule which chaperones portions of the binding assembly so that specific component combinations and geometries can be achieved. This molecule is designated here as a PILOT. Pilots can be comprised of proteins or any combination of organic and inorganic materials which achieve the combinatorial selection and/or to induce specific geometries between members of the TBA or BBAs. A chaperone is a stable scaffold upon which a TBA or BBA may be constructed such that the correct conformation of the TBA or BBA is provided while at the same time eliminating undesirable properties of a naturally occurring nucleic acid binding protein. As a specific example of this embodiment, a modified version of the pleiotropic transcription factor, NF-kB, is provided using a modified bacteriophage lambda *cro* protein as the chaperone. Each NF-kB binding dimer retains the picomolar binding affinity for the NF-kB binding site while at the same time the binding assembly presents several advantageous manufacturing, stability, and specificity characteristics.

In view of the foregoing, the various aspects and embodiments of this invention are described below in detail.

5 1. The Probe Nucleic Acids (PNAs) and their preparation. The PNAs of the present invention comprise at least three principal parts joined together. With reference to Figure 1(I) of the drawings, the first part of the PNA is one or more sequences of bases, designated "1/2 TBR." With reference to Figure 1(I and IIa) of the drawings, the 1/2 TBR in the PNA is complementary to a sequence of interest in a sample, the TNA containing a 1/2 TBR. With reference to Figure 1(IIIa) of the drawings, the TNA, when added to the PNA under hybridizing conditions, forms a PNA-TNA hybrid containing a TBR. With reference to Figure 1(I) of the drawings, the second part of the PNA
10 is a sequence of bases, designated "1/2 BBR." With reference to Figure 1(I, IIb, IIc, and IVa) of the drawings, the 1/2 BBR in the PNA is complementary to a 1/2 BBR contained in a BNA or a HNA. With reference to Figure 1(IIIb, IIIc, and Va) of the drawings, the BNA or HNA, when added to the PNA under hybridizing conditions, forms a PNA-BNA hybrid or PNA-HNA hybrid, respectively, containing a BBR. With reference to Figure 1(I) of the drawings, the third part of the PNA is the
15 OSA, designated by a circle with a box around it. The OSA is no support and/or an indicator, or solid support, or other means of localization, including but not limited to, attachment to beads, polymers, and surfaces and/or indicators which is/are covalently attached to, or non-covalently, but specifically, associated with the PNA. The OSA may be an atom or molecule which aids in the separation and/or localization such as a solid support binding group or label which can be detected
20 by various physical means including, but not limited to, adsorption or imaging of emitted particles or light. Methods for attaching indicators to oligonucleotides or for immobilizing oligonucleotides to solid supports are well known in the art (see Keller and Manak, *supra*, herein incorporated by reference).

25 The PNA of the present invention can be prepared by any suitable method. Such methods, in general, will include oligonucleotide synthesis and cloning in a replicable vector. Methods for nucleic acid synthesis are well-known in the art. When cloned or synthesized, strand purification and separation may be necessary to use the product as a pure PNA. Methods of preparing RNA probes are well known (see for example Blais 1993, Blais 1994, which uses *in vitro* transcription from a PCR reaction incorporating a T7 RNA polymerase promoter).

30 The length and specific sequence of the PNA will be understood by those skilled in the art to depend on the length and sequence to be detected in a TNA, and the strictures for achieving tight and specific binding of the particular TBA to be used (see discussion on TBAs below). In general, PNAs of sequence lengths between about 10 and about 300 nucleotides in length are adequate, with

lengths of about 15-100 nucleotides being desirable for many of the embodiments specifically exemplified herein.

It should also be understood that the PNA may be constructed so as to contain more than one 1/2 TBR and to produce more than one TBR for one or more TBAs, same or different, as well as complex TBRs recognized by novel duplex and multiplex TBAs (see description below regarding these novel TBAs) upon hybridization of the PNAs and TNAs. Figure 5 illustrates specific PNAs which contain one or more 1/2 TBRs. Specific sequences which correspond to the 1/2 TBR sequences illustrated in Figure 5 (Ia, IIa, IIIa, IVa, and Va) are SEQ ID NOS. 1-34 (see Description of Sequences above).

As shown in Figures 2a and 2b, the PNA, containing a 1/2 TBR, may be hybridized with one or more BNAs (see description below) and the chain of BNAs polymerized to any desired potential length for amplification of the TNA-PNA hybridization event. Preferably, between about 0 and about 10 1/2 BBRs will be present in the PNA.

As shown in Figures 6a and 6b, the PNA may contain several 1/2 TBRs, same or different, which can hybridize with several 1/2 TBRs in a TNA. Each time a 1/2 TBR in the PNA matches a 1/2 TBR in a TNA, a Target Binding Region, TBR, is formed which can bind a TBA. Furthermore, it is not essential that all of the TBRs be on a single, contiguous PNA. Thus, in one embodiment of the invention, two different PNAs are used to detect sequences on a particular TNA. As an illustration of this aspect of the invention, Figure 7 shows one representation of the human immunodeficiency virus (HIV) long terminal repeat (LTR). As is known in the art, the HIV LTR comprises two NF-kB binding sites and three SP1 binding sites, in close proximity, wherein NF-kB and SP1 are known DNA binding proteins. Figure 7 provides two PNAs, PNA1 (SEQ ID NO. 38) and PNA2 (SEQ ID NO. 39), each of which is complementary to the opposite strand shown as a TNA (SEQ ID NO. 37), which shows the two NF-kB binding sites and the three SP1 binding sites of the HIV LTR. According to this aspect of the invention, PNA1 specifically hybridizes with that section of the TNA shown in Figure 7 with bases underscored with a "+" symbol, while PNA2 specifically hybridizes with that section of the TNA shown in Figure 7 with bases underscored with an "=" symbol. Each of PNA1 or PNA2 may also contain sequences (indicated by the symbols "#" or "*"") which will hybridize with a BNA's 1/2 BBR sequences (see below). In addition, each of PNA1 and PNA2 may be differentially tagged with an OSA, such as a fluorophore such as a fluorescein or a rhodamine label, which would allow confirmation that both probes have become bound to the TNA. If only one label or neither label is detected, it is concluded that the TNA is not present in the sample being tested.

In a further aspect of the embodiment shown in Figure 7, a method for altering the specificity of the instant assay method is shown. By changing the length of the gap between PNA1 and PNA2, such that the region of TNA remaining unhybridized is altered, one practicing this invention is able to alter the discrimination of the assay.

5 In order to more clearly exemplify this aspect of the invention, it is necessary to emphasize that the TBR may have a helical structure. Thus, while PNA1 creates TBRs on one "face" of the helix, PNA2 creates a TBR on either the same or a different face of the helix, depending on the distance between the middle of each TBR (underlined in Figure 7). If the middle of each binding site is an integral product of 10.5 bases apart, the TBRs will be on the same side of the helix, while non-integer products of 10.5 bases apart would place the TBRs on opposite sides of the helix. In this fashion, any cooperativity in binding by the TBA recognizing the PNA1 TBR and the TBA recognizing the PNA2 TBR can be manipulated (see Hochschild, A., M. Ptashne [1986] *Cell* 44:681-687, showing this effect for the binding of bacteriophage lambda repressor to two different operator sites located at different distances from each other in a DNA helix). As described by 10 Perkins *et al.* ([1993] *EMBO J.* 12:3551-3558), cooperativity between NF-kB and the SP1 sites is required to achieve activation of the HIV LTR. However, for the purpose of the instant invention, the double NF-kB-triple SP1 binding site motif in the HIV LTR may be taken advantage of by providing a single, novel binding protein capable of binding both sites simultaneously, but only if the spacing between the sites is geometrically feasible. This is controlled both by the structure of 15 the selected TBA and by the PNAs used. Thus, in the embodiment exemplified in Figure 7, the two probes may be used with a large enough interprobe region of single-stranded DNA remaining such that, even if the NF-kB and SP1 binding sites are on opposite sides of the helix, the single-stranded region between the probes provides a sufficiently flexible "hinge" so that the DNA can both bend and twist to accommodate the geometry of the TBA. Alternatively, a more stringent assay may be 20 designed by narrowing the interprobe distance such that the DNA may only bend, but not twist. Finally, the probes may be so closely spaced, or a single PNA used, such that the DNA can only bend but not twist. Thus, this figure exemplifies and enables the production of detection systems with any given desired degree of discrimination between target nucleic acids having similar sequences, but different juxtapositions of these sequences.

30 In terms of a diagnostic or forensic kit for HIV, those skilled in the art would understand that the aforementioned aspects of this invention allow for the tailoring of the components of the diagnostic or forensic kit to match what is known at any given time about the prevalent strains of HIV or another pathogen or disease condition. It will also be appreciated by those skilled in the art that, while detection of HIV infection is not the only utility of the instant invention, due to the

mutability of the HIV genome, it is probably one of the most complex test environments for such a diagnostic. It is precisely in such a mutable environment, however, where the flexibility of the instant method, coupled with its ability to discriminate between very closely related sequences, may be most clearly appreciated. In less mutable environments, some of the sophistication to which this invention is amenable need not be utilized. Thus, in a diagnostic kit for papillomavirus infection, all of the discrimination characteristics of the TBA-TBR interaction are available, along with the ability to amplify the signal using the BNAs and BBAs, but a single, simple PNA, such as any one of SEQ ID NOS. 46-62, may be used which identifies unique papillomavirus sequences, which also are known to bind to a TBA such as the papillomavirus E2 protein or truncated DNA binding portions thereof (see Hegde *et al.* [1992] *Nature* 359:505-512; Monini *et al.* [1991] *J. Virol.* 65:2124-2130).

In applying the instant method to the detection of a particular TNA for the purposes of assessing whether certain nucleic acids are present which are associated with the progression of melanoma, hepatoma, breast, cervical, lung, colon, prostate, pancreatic or ovarian cancers, the TNA may be obtained from biopsy materials taken from organs and fluids suspected of containing the cancerous cells. For the detection of genetic deficiencies, the TNA may be obtained from patient samples containing the affected cells. For detection of fermentation contaminants and products in the manufacture of food, chemical or biotechnology products or in the bioremediation of wastes, the TNA may be obtained from samples taken at various stages in the fermentation or treatment process. For detection of food or drug pathogens or contaminants, the TNA sample may be obtained from the food or drug, swabs of food or surfaces in contact with the food, fluids in contact with the food, processing materials, fluids and the like associated with the manufacture of or in contact with the food, drug, or biological samples taken from those in contact with the food or drug or the like.

2. The Booster Nucleic Acids (BNAs), Booster Binding Regions (BBRs) and their preparation. The BNAs of the present invention are comprised of at least one or more 1/2 BBRs coupled to an OSA. The 1/2 BBRs can hybridize to complementary 1/2 BBRs contained in the PNA, other BNAs or an HNA.

With reference to Figure 1(I, IIb and IIIb) of the drawings, the simplest BNA is comprised of two parts. With reference to Figure 1(IIb) of the drawings, the first part of the simplest BNA is a sequence of bases which is complementary to the sequence in the PNA which is designated "1/2 BBR." With reference to Figure 1(IIb) of the drawings, the second part of the simplest BNA is the OSA, designated by a circle with a box around it. The OSA is no support and/or indicator, or solid support, or other means of localization, including but not limited to, attachment to beads, polymers,

and surfaces and/or indicators which are covalently attached to, or non-covalently, but specifically, associated with the BNA.

5 With reference to Figure 2a(II and III) of the drawings, the BNA may contain more than one 1/2 BBR sequence. The BNA illustrated in Figure 3(II) contains a sequence which is complementary to the PNA illustrated in Figure 3(I) and two other 1/2 BBR sequences. The BNA illustrated in Figure 3(III) contains two 1/2 BBR sequences which are complementary to two of the 1/2 BBR sequences in the BNA illustrated in Figure 3(II), plus up to "n" additional 1/2 BBRs for polymerization of additional BNAs.

10 Under hybridizing conditions, the BNA illustrated in Figure 3(II), when combined with the PNA illustrated in Figure 3(I), creates the PNA-BNA hybrid illustrated in Figure 3(IVa) containing a BBR and an unhybridized extension with two additional 1/2 BBR sequences or "booster" sequences. The BBRs created by said hybridization can be identical, similar or dissimilar in sequence. The BBRs created by said hybridization can bind identical, similar or dissimilar BBAs (see below). The BNAs may have prepared analogously to the PNAs.

15 Under hybridizing conditions, the BNA-BNA hybrid illustrated in Figure 3(IVb), when combined with the PNA illustrated in Figure 3(Vb), creates the PNA-BNA hybrid illustrated in Figure 3(VI) containing a BBR, two additional BNA-BNA hybrids containing BBRs, and an unhybridized extension with an additional 1/2 BBR sequence, a "booster" sequence. The BBRs created by said hybridization can be identical, similar or dissimilar in sequence. The BBRs created by said hybridization can bind identical, similar or dissimilar BBAs (see below). The BNAs may be prepared in a fashion analogous to preparation of the PNAs.

20 3. The Target Nucleic Acids (TNAs) and their preparation. The first step in detecting and amplifying signals produced through detection of a particular TNA according to the present method is the hybridization of such target with the PNA in a suitable mixture. Such hybridization is achieved under suitable conditions well known in the art.

25 The sample suspected or known to contain the intended TNA may be obtained from a variety of sources. It can be a biological sample, a food or agricultural sample, an environmental sample and so forth. In applying the instant method to the detection of a particular TNA for the purposes of medical diagnostics or forensics, the TNA may be obtained from a biopsy sample, a body fluid or exudate such as urine, blood, milk, cerebrospinal fluid, sputum, saliva, stool, lung aspirates, throat or genital swabs and the like. In addition, detection may be *in situ* (see for example Embretson 1993; Patterson 1993; Adams 1994).

30

Accordingly, PNAs specific to vertebrates (including mammals and including humans) or to any or all of the following microorganisms of interest may be envisioned and used according to the instant method:

- 5 Corynebacteria
Corynebacterium diphtheria
- Bacillus
Bacillus thuringiensis
- Pneumococci
Diplococcus pneumoniae
- 10 Streptococci
Streptococcus pyogenes
Streptococcus salivarius
- Staphylococcus
Staphylococcus aureus
15 *Staphylococcus albus*
- Pseudomonas
Pseudomonas stutzen
- Neisseria
Neisseria meningitidis
20 *Neisseria gonorrhoea*
- Enterobacteriaceae
Escherichia coli
Aerobacteria aerogenes
Klebsiella pneumoniae The coliform bacteria
25 *Salmonella typhosa* The Salmonellae
Salmonella choleraesuis
Salmonella typhimurium
Shigellae dysenteriae
Shigellae schmitzii
30 *Shigellae arabinotarda* The Shigellae
Shigellae flexneri
Shigellae boydii
Shigellae sonnei
- Other enteric bacilli
35 *Proteus vulgaris*
Proteus mirabilis Proteus species
Proteus morgani
Pseudomonas aeruginosa
Alcaligenes faecalis
40 *Vibrio cholerae*
- Hemophilus-Bordetella group
Hemophilus influenza, H. ducryi
Hemophilus hemophilus
Hemophilus aegypticus
45 *Hemophilus parainfluenzae*
Bordetella pertussis
- Pasteurellae
Pasteurella pestis
50 *Pasteurella tularensis*

- Brucellae
Brucella melitensis
Brucella abortus
Brucella suis
- 5 Aerobic Spore-Forming Bacilli
Bacillus anthracis
Bacillus subtilis
Bacillus megaterium
Bacillus cereus
- 10 Anaerobic Spore-Forming Bacilli
Clostridium botulinum
Clostridium tetani
Clostridium perfringens
Clostridium novyi
15 *Clostridium septicum*
Clostridium histolyticum
Clostridium tertium
Clostridium bifermentans
Clostridium sporogenes
- 20 Mycobacteria
Mycobacterium tuberculosis hominis
Mycobacterium bovis
Mycobacterium avium
Mycobacterium leprae
25 *Mycobacterium paratuberculosis*
- Actinomycetes (fungus-like bacteria)
Actinomyces israeli
Actinomyces bovis
Actinomyces naeslundii
30 *Nocardia asteroides*
Nocardia brasiliensis
- The Spirochetes
Treponema pallidum
Treponema pertenue
35 *Treponema carateum*
Spirillum minus
Streptobacillus moniliformis
Borrelia recurrentis
Leptospira icterohemorrhagiae
40 *Leptospira canicola*
- Trypanosomes
Mycoplasmas
Mycoplasma pneumoniae
- Other pathogens
45 *Listeria monocytogenes*
Erysipelothrix rhusiopathiae
Streptobacillus moniliformis
Donovania granulomatis
50 *Bartonella bacilliformis*

	<u>Rickettsiae</u> (bacteria-like parasites)	
	<i>Rickettsia prowazekii</i>	
	<i>Rickettsia mooseri</i>	
	<i>Rickettsia rickettsii</i>	
5	<i>Rickettsia conori</i>	
	<i>Rickettsia australis</i>	
	<i>Rickettsia sibiricus</i>	
	<i>Rickettsia akari</i>	
	<i>Rickettsia tsutsugamushi</i>	
10	<i>Rickettsia burnetti</i>	
	<i>Rickettsia quintana</i>	
	<u>Chlamydia</u> (unclassifiable parasites bacterial/viral)	
	Chlamydia agents (naming uncertain)	
	<u>Fungi</u>	
15	<i>Cryptococcus neoformans</i>	
	<i>Blastomyces dermatidis</i>	
	<i>Histoplasma capsulatum</i>	
	<i>Coccidioides immitis</i>	
	<i>Paracoccidioides brasiliensis</i>	
20	<i>Candida albicans</i>	
	<i>Aspergillus fumigatus</i>	
	<i>Mucor corymbifera</i> (<i>Absidia corymbifera</i>)	
	<i>Rhizopus oryzae</i>	
	<i>Rhizopus arrhizus</i>	Phycomycetes
25	<i>Rhizopus nigricans</i>	
	<i>Sporotrichum schenkii</i>	
	<i>Flonsecaea pedrosoi</i>	
	<i>Fonsecaea compact</i>	
	<i>Fonsecaea dermatidis</i>	
30	<i>Cladosporium carrioni</i>	
	<i>Phialophora verrucosa</i>	
	<i>Aspergillus nidulans</i>	
	<i>Madurella mycetomi</i>	
	<i>Madurella grisea</i>	
35	<i>Allescheria boydii</i>	
	<i>Phialophora jeanselmei</i>	
	<i>Microsporium gypsum</i>	
	<i>Trichophyton mentagrophytes</i>	
	<i>Keratinomyces ajelloi</i>	
40	<i>Microsporium canis</i>	
	<i>Trichophyton rubrum</i>	
	<i>Microsporium adouini</i>	
	<u>Viruses</u>	
	Adenoviruses	
45	<u>Herpes Viruses</u>	
	<i>Herpes simplex</i>	
	<i>Varicella</i> (Chicken pox)	
	<i>Herpes zoster</i> (Shingles)	
	Virus B	
50	Cytomegalovirus	

- Pox Viruses
 Variola (smallpox)
 Vaccinia
 Poxvirus bovis
 5 Paravaccinia
Molluscum contagiosum
- Picornaviruses
 Poliovirus
 Coxsackievirus
 10 Echoviruses
 Rhinoviruses
- Myxoviruses
 Influenza (A, B, and C)
 Parainfluenza (1-4)
 15 Mumps virus
 Newcastle disease virus
 Measles virus
 Rinderpest virus
 Canine distemper virus
 20 Respiratory syncytial virus
 Rubella virus
- Arboviruses
 Eastern equine encephalitis virus
 Western equine encephalitis virus
 25 Sindbis virus
 Chikugunya virus
 Semliki forest virus
 Mayora virus
 St. Louis encephalitis virus
 30 California encephalitis virus
 Colorado tick fever virus
 Yellow fever virus
 Dengue virus
- Reoviruses
 35 Reovirus types 1-3
- Retroviruses
 Human immunodeficiency viruses (HIV)
 Human T-cell lymphotropic virus I & II (HTLV)
- Hepatitis
 40 Hepatitis A virus
 Hepatitis B virus
 Hepatitis nonA-nonB virus
 Hepatitis, C, D, E
- Tumor viruses
 45 Rauscher leukemia virus
 Gross virus
 Maloney leukemia virus
 Human papilloma viruses

It would be understood by one of skill in the art that it is generally required to treat samples suspected of containing a particular TNA in such a fashion as to produce fragments that can easily hybridize with the PNA. It may be necessary to treat the test sample to effect release of or to extract the TNA for hybridization, such as by exposing blood or other cells to a hypotonic environment, or otherwise disrupting the sample using more vigorous means. When the TNA is thought to be present in double stranded form, it would naturally be desirable to separate the strands to render the TNA hybridizable in single stranded form by methods well known in the art, including but not limited to heating or limited exposure to alkaline conditions which may be neutralized upon addition of the single stranded PNA to allow hybridization to occur. Methods for preparing RNA targets are well known (see Waterhouse 1993, Mitchell 1992).

Fragmentation of nucleic acid samples containing TNAs is usually required to decrease the sample viscosity and to increase the accessibility of the TNAs to the PNAs. Such fragmentation is accomplished by random or specific means known in the art. Thus, for example, specific nucleases known to cut with a particular frequency in the particular genome being analyzed, may be used to produce fragments of a known average molecular size. In addition, other nucleases, phosphodiesterases, exonucleases and endonucleases, physical shear and sonication are all methods amenable for this purpose. These processes are well known in the art. The use of restriction enzymes for the purpose of DNA fragmentation is generally preferred. However, DNA can also be fragmented by a variety of chemical means such as the use of the following types of reagents: EDTA-Fe(II) (according to Stroebel *et al.* [1988] *J. Am. Chem. Soc.* 110:7927; Dervan [1986] *Science* 232:464); Cu(II)-phenanthroline (according to Chen and Sigman [1987] *Science* 237:1197); class IIS restriction enzyme (according to Kim *et al.* [1988] *Science* 240:504); hybrid DNase (according to Corey *et al.* [1989] *Biochem.* 28:8277); bleomycin (according to Umezawa *et al.* [1986] *J. Antibiot.* (Tokyo) Ser. A, 19:200); neocarzinostatin (Goldberg *et al.* [1981] *Second Annual Bristol-Myers Symposium in Cancer Research*, Academic Press, New York, p.163); and methidiumpropyl-EDTA-Fe(II) (according to Hertzberg *et al.* [1982] *J. Am. Chem. Soc.* 104:313). Removal of proteins, as by treatment with a protease, is also generally desirable and methods for effecting protein removal from nucleic acid samples, without appreciable loss of nucleic acid, are well known in the art.

The TNAs of the present invention should be long enough so that there is a sufficient amount of double-stranded hybrid flanking the TBR so that a TBA can bind unperturbed by the unligated fragment ends. Typically, fragments in the range of about 10 nucleotides to about 100,000 nucleotides, and preferably in the range of about 20 nucleotides to about 1,000 nucleotides are used as the average size for TNA fragments. Examples of specific TNA sequences that could be detected

are sequences complementary to the PNA sequences described herein for detection of normal cellular, abnormal cellular (as in activated oncogenes, integrated foreign genes, genetically defective genes), and pathogen-specific nucleic acid sequences, for which specific nucleic acid binding proteins are known, or which can be produced according to methods described in this disclosure. With
5 reference to Figure 7, a specific HIV-related TNA is shown as SEQ ID NO. 37.

4. Extensions to the PNA using BNAs, their preparation, and signal amplification. Under hybridizing conditions, BNAs can be added that hybridize to the PNAs, PNA-BNA hybrids, BNAs and/or BNA-BNA hybrids. The aforementioned additions can be made in a non-vectorial polymeric fashion or in a vectorial fashion, with a known order of BNAs.

10 With reference to Figure 2a, a simple booster is presented. A booster polymer is produced by adding two BNAs, illustrated in Figure 2a(Ib and Ic), which when combined under hybridizing conditions with the PNA, form PNA-BNA-BNA hybrids, comprised of the PNA and "booster" extensions", illustrated in Figure 2a(IIa,IIb,IIc and IId) leaving at least one unpaired 1/2 BBR sequence. Each unpaired 1/2 BBR sequence, illustrated in Figure 2a(IIa, IIb, IIc, IId) can hybridize
15 with additional BNAs to form additional "booster" extensions. Each unpaired 1/2 BBR sequence, illustrated in Figure 2a(IIa,IIb,IIc and IId) can hybridize with added HNAs, illustrated in Figure 2a(IIIa and IIIb). The hybridization of the HNAs, which cannot hybridize additional BNAs, acts to "cap" the addition of the BNAs onto the PNA, as illustrated in Figure 2a(IVa, IVb, IVc and IVd).

20 With reference to Figure 2b, it is possible to control and specify the order and components of extensions to the PNA. If a single BBR is required, a HNA containing the complementary sequence to the 1/2 BBR in the PNA is added to the PNA to produce a single BBR and to "cap" any "booster" extensions to the PNA. If additional BBRs are to be added to the PNA, a controlled extension of the PNA can be accomplished.

25 With reference to Figure 2b, a simple booster is presented. Vectorial polymer extension is accomplished by adding a BNA which is specific for the PNA, as illustrated in Figure 2b(Ia and IIa), which when combined under hybridizing conditions with the PNA, form PNA-BNA-BNA hybrids, comprised of the PNA and "booster" extensions. These extensions, if labeled with an OSA, provide a method for greatly amplifying any signal produced upon binding of a PNA to a TNA in the sample. Furthermore, by binding labeled BBAs to the BBRs in the polymer, additional amplification is
30 achieved.

Any of a number of methods may be used to prepare the BNAs, including, *e.g.*, synthesis via known chemistry or via recombinant DNA production methods. In the latter method, an essentially unlimited number of BNAs may be produced simply and inexpensively, for example, by production in prokaryotes (*E. coli* for example) of a plasmid DNA having multiple repeats of the

specific BNA sequences flanked by restriction sites having overhanging ends. In this fashion, for example, the bacteriophage lambda left or right operator sites, or any other DNA or other nucleic acid sequence known to specifically and tightly bind a particular BBA, such as a DNA or RNA binding protein, may be produced in an essentially unlimited number of copies, with each copy flanked by an *EcoRI*, *PstI*, *BamHI* or any of a number of other common restriction nuclease sites. Alternatively, a polymer at repeated sites may be excised by unique restriction sites not present within the polymer. Large quantities of pBR322, pUC plasmid or other plasmid having multiple copies of these sequences are produced by methods well known in the art, the plasmid cut with the restriction enzyme flanking the polymerized site, and the liberated multiple copies of the operators isolated either by chromatography or any other convenient means known in the art. The BNA, prior to use, is then strand separated and is then amenable for polymerization onto a PNA encoding a single stranded complementary copy of the operator as a 1/2 BBR. The BNAs may be polymerized vectorially onto the PNA by using different restriction enzymes to flank each repeat of the polymer in the plasmid used to produce multiple copies of the BNA. Alternatively, the BNA polymer may be hybridized to the PNA via overhangs at one or both ends of the BNA polymer, without the need to strand separate and anneal each BNA segment. Examples of specific BNA sequences are provided above in the section entitled Description of Sequences, as SEQ ID NOS. 35-36. To stabilize the BNA polymer, DNA ligase may be used to covalently link the hybridized BNAs.

5. The Hairpin Nucleic Acids (HNAs) and their preparation. The HNAs of the present invention comprise at least two principal parts joined together: A single-stranded sequence, which is complementary to a 1/2 BBR, and a double-stranded nucleic acid region formed, under hybridizing conditions, by the self-association of self-complementary sequences within the HNA. With reference to Figure 1(IIc) of the drawings, the 1/2 BBR in the HNA may be constructed so as to be complementary to the 1/2 BBR sequence in the PNA. With reference to Figure 1(I, IIc and IIIc) of the drawings, the aforementioned HNA, when added to the PNA under hybridizing conditions, forms a PNA-HNA hybrid containing a BBR. With reference to Figure 1(IIIc, IVc and Vc) of the drawings, a PNA-HNA hybrid, under hybridizing conditions, upon addition of the TNA, can form a TNA-PNA-HNA hybrid containing a TBR and a BBR.

With reference to Figure 2a and 2b, the HNAs can be used to "cap" or terminate the addition of BNA extensions to the PNA. The two BNAs in Figure 2a(Ib and Ic) can associate to form the hybrid shown in Figure 3(IVb) or can hybridize directly and individually to the PNA as illustrated in Figure 2a(Ia-c, IIa-d). The two HNAs (shown in Figure 2a(IIIa and IIIb)) can terminate the hybridization of the BNA to other BNAs which extend from the PNA, as illustrated in Figure 2a(IVa-d). The HNA in Figure 2a(IIIa) can terminate the PNA-BNA hybrids shown in Figure 2a(IIb

and IIId) and any PNA-BNA hybrid with a single stranded 1/2 BBR which is complementary to the 1/2 BBR in the HNA illustrated in Figure 2a(IIIa). Similarly, the HNA in Figure 2a(IIIb) can terminate the PNA-BNA hybrids shown in Figure 2a(IIa and IIc) and any PNA-BNA hybrid with two single stranded 1/2 BBRs which are complementary to the 1/2 BBRs in the HNA illustrated in Figure 2a(IIIb).

HNAs are constructed that will terminate PNA-BNA hybrids which are constructed from the sequential addition of BNAs to the PNA as illustrated in Figure (2b). The single stranded 1/2 BBR sequences illustrated in Figure 2b(Ia, IIIa, Va, and VIIa) are specifically complementary to the single stranded 1/2 BBR sequences illustrated in Figure 2b(Ib,IIIb,Vb and VIIb) and produce the unique capped PNA-BNA-HNA hybrids illustrated in Figure 2b(Ic,IIIc,Vc and VIIc).

The self-complementary sequences in the HNA and the loop sequence which links the self-complementary hairpin sequences can be of any composition and length, as long as they do not substantially impede or inhibit the presentation of the single-stranded 1/2 BBR that comprises part of the HNA by the HNA or selectively bind the BBA or the TBA. The loop sequences should be selected so that formation of the loop does not impede formation of the hairpin. An examples of an HNA useful in this application is provided as SEQ ID NO. 44 (see Description of Sequences above).

6. The Target Binding Assemblies (TBAs) and their preparation. A TBA may be any substance which binds a particular TBR formed by hybridization of particular TNAs and PNAs, provided that the TBA must have at least the following attributes:

- (a) The TBA must bind the TBR(s) in a fashion that is highly specific to the TBR(s) of interest. That is, the TBA must discriminate between TBRs present in the TNA-PNA hybrid and similar duplex sequences formed by PNA-CNA hybrids. The TBA must bind the PNA-CNA hybrid with a sufficiently low avidity that upon washing the TBA-TNA-PNA complex, the PNA-CNA hybrid is displaced and the PNA-TNA hybrid is not displaced;
- (b) The TBA must avidly bind the TBR(s) created by the hybridization of the TNA with the PNA. Binding affinities in the range of 10^{-5} to about 10^{-12} or higher are generally considered sufficient. As noted below, in some instances, it might be desirable to utilize a particular TBA which has a very low avidity for a particular TBR, but which has a greatly increased affinity when a particular configuration of multiple TBRs is provided so that the square of the affinity of the TBA for each TBR becomes the affinity of relevance to that particular TBA.

Examples of the DNA binding components useful in the formation of TBAs include, but are not limited to NF-kB, papillomavirus E2 protein, transcription factor SP1, inactive restriction

enzymes, antibodies, *etc.* Each of these proteins has been recognized in the art to contain sequences which bind to particular nucleic acid sequences and the affinities of these interactions are known. Naturally, the method of the instant invention is not limited to the use of these known DNA binding proteins or fragments thereof. From the instant disclosure, it would be apparent to one of ordinary skill that the instant method could easily be applied to the use of novel TBAs exhibiting at least the required attributes noted above. Thus, for example, in WO 92/20698, a sequence specific DNA binding molecule comprising an oligonucleotide conjugate formed by the covalent attachment of a DNA binding drug to a triplex forming oligonucleotide was described. The method of that disclosure could be used to produce novel TBAs for use according to the instant disclosure, provided that the TBAs thus formed meet the criteria described above. In addition, the methods of U.S. Patent Nos. 5,096,815, 5,198,346, and WO88/06601, herein incorporated by reference, may be used to generate novel TBAs for use according to the method of this invention. Specific antibodies or portions thereof could be used (see for example Blais 1994).

Where the TBA is a protein, or a complex of proteins, it will be recognized that any of a number of methods routine in the art may be used to produce the TBA. The TBA may be isolated from its naturally occurring environment in nature, or if this is impractical, produced by the standard techniques of molecular biology. Thus, using NF-kB as an example, using the DNA binding portions of p50 or p65 subunits, this binding assembly could be produced according to recombinant methods known in the art (see for example Ghosh [1990] *Cell* 62:1019-1029, describing the cloning of the p50 DNA binding subunit of NF-kB and the homology of that protein to *rel* and *dorsal*).

Many DNA and other nucleic acid binding proteins are known which can be used as or in TBAs according to this invention. Once the amino acid sequence of any DNA, RNA:DNA, RNA or other nucleic acid binding protein is known, an appropriate DNA sequence encoding the protein can either be prepared by synthetic means, or a cDNA copy of the mRNA encoding the protein from an appropriate tissue source can be used. Furthermore, genomic copies encoding the protein may be obtained and introns spliced out according to methods known in the art. Furthermore, the TBAs may be chemically synthesized.

Once an appropriate coding sequence has been obtained, site-directed mutagenesis may be used to alter the amino acid sequence encoded to produce mutant nucleic acid binding proteins exhibiting more desirable binding characteristics than those of the original nucleic acid binding protein. As an example of this process, the amino acid sequence of the DNA binding portions of NF-kB can be altered so as to produce an NF-kB' molecule which more tightly binds the NF-kB binding site (see examples below - HIV-Detect and HIV-Lock).

To provide further insight into this aspect of the invention, the following considerations are to be noted. Using NF-kB as an example, a TBA may be prepared using the naturally occurring NF-kB molecule. However, because this molecule is present in vanishingly small quantities in cells, and because the subunits of this DNA binding protein have been cloned, it would be more reasonable to prepare large quantities of the complex via recombinant DNA means as has already been accomplished for this protein (see for example Ghosh [1990] *Cell* 62:1019-1029). NF-kB is a pleiotropic inducer of genes involved in immune, inflammatory and growth regulatory responses to primary pathogenic (viral, bacterial or stress) challenges or secondary pathogenic (inflammatory cytokine) challenges. NF-kB is a dimeric DNA binding protein comprising a p50 and a p65 subunit, both of which contact and bind to specific DNA sequences. In an inactivated state, NF-kB resides in the cellular cytoplasm, complexed with a specific inhibitor, I-kB, to form a cytoplasmic heterotrimer. Upon activation, the inhibitor is decomplexed, and the p50-p65 dimer relocates via a specific nuclear localization signal (NLS) to the cell's nucleus where it can bind DNA and effect its role as a transcriptional activator of numerous genes (see Grimm and Baeuerle [1993] *Biochem. J.* 290:297-308, for a review of the state of the art regarding NF-kB).

The p50-p65 dimer binds with picomolar affinity to sequences matching the consensus GGGAMTNYCC (SEQ ID NO. 117), with slightly different affinities depending on the exact sequence. It is worth noting that homodimers of p50 and p65 have also been observed to occur. These homodimers display different biochemical properties as well as slightly different affinities of binding sequences within and similar to the above consensus. Thus, depending on the desired binding characteristics of the TBA, a p50-p65 heterodimer, a p50-p50 homodimer, or a p65-p65 homodimer or fragments of the aforementioned dimers may be used.

One way in which various novel TBAs may be produced for use according to this invention is shown schematically in Figure 9. The nucleic acid recognition units of the TBA may be assembled and associated with similar or dissimilar TBA nucleic acid recognition units via a "chaperone." The chaperone is a structure on which the various TBA recognition elements are built and which confers desirable properties on the nucleic acid recognition units. The chaperone is comprised of any sequence which provides assembly sequences such that same or different nucleic acid recognition units are brought into close and stable association with each other. Thus, for example, in the case of a TBA designed to tightly bind NF-kB TBRs, a TBA is assembled by providing lambda *cro* sequences as assembly sequences, linked to the nucleic acid binding sequences for either NF-kB p50 or p65. The p50 or p65 nucleic acid binding sequences are linked to the *cro* sequences at either the carboxy or amino terminus of *cro* and either the carboxy or amino terminus of the nucleic acid

recognition unit of the p50 or p65. Linking sequences are optionally provided to allow appropriate spacing of the nucleic acid recognition units for optimal TBR binding.

The assembly sequences, exemplified above by *cro* and CI sequences (SEQ ID NOS. 104-108), comprise any stable oligopeptides which naturally and strongly bond to like sequences. Thus, in the case of *cro*, it is well known that a dimer of *cro* binds to the bacteriophage lambda operator sites (Anderson *et al.* [1981] *Nature* 290:754-758; Harrison and Aggarwal [1990] *Ann. Rev. Biochem.* 59:933-969). The monomer units of *cro* tightly and specifically associate with each other. Thus, by linking DNA recognition unit sequences to the *cro* sequences, close and tight association is achieved.

The optional linker sequences comprise any amino acid sequence which does not interfere with TBA assembly or nucleic acid binding, and which is not labile so as to liberate the nucleic acid recognition unit from the complete TBA. It is desirable but not necessary that the linker sequences be covalently linked to other binding assembly components. The association should be specific so as to aid in the assembly and manufacture of the binding assemblies. Examples of such sequences include, but are not limited to, such well known sequences as are found linking various domains in structural proteins. Thus, for example, in the lambda repressor protein, there is a linking sequence between the DNA binding domain and the dimerization domain which is useful for this purpose. Many other such sequences are known and the precise sequence thereof is not critical to this invention, provided that routine experimentation is conducted to ensure stability and non-interference with target nucleic acid binding. Examples of such sequences are provided herein as Met Ser and SEQ IN NOS. 99-102. Insertion of specific, known proteolysis sites into these linkers is also an integral part of this invention. The presence of such sites in the linker sequences would provide manufacturing advantages, allowing different molecules to be assembled on the chaperone scaffold.

In addition to the nucleic acid recognition units, optional linking sequences, and assembly sequences, the novel TBAs of this invention optionally have asymmetry or PILOT TNA sequences and one or more OSA units. The asymmetry sequences are provided to encourage or prevent certain desirable or undesirable associations. For example, in the event that a TBA having homodimeric p50 DNA recognition units is desired, the asymmetry sequences are provided to disrupt the naturally stronger association of NF-kB p50 subunits and p65 subunits, while not disrupting the assembly sequences from bringing together p50 subunits. Examples of such sequences are provided herein as SEQ ID NOS. 85-92 and SEQ ID NOS. 105 and 106.

In a different configuration, NF-kB p50 subunit sequences are brought into close association with transcription factor SP1 DNA recognition unit sequences. This is desirable in the event that an NF-kB/SP1 binding motif is of significance, as in the HIV LTR where a motif of at least six DNA

binding protein recognition sites, two NF-kB, three SP1, and a TATA site are known to exist. Since it is also known that the second NF-kB and first SP1 site are significant to regulation of HIV transcription (Perkins *et al.* [1993] *Embo J.* 12:3551-3558), this particular configuration of TBA is useful not only in the detection of HIV, but as a therapeutic or prophylactic against HIV infection (see below). In a similar fashion, the long control region (LCR) of human papillomavirus may be used as a key control region for probing according to this method.

In view of the different elements that can be associated, cassette fashion, according to this method of TBA formation, an essentially unlimited variety of TBAs are produced. In Figure 10, a series of different molecules, referred to as "HIV-detect I-IV" are exemplified wherein "CHAP" denotes the chaperone, "nfkB" denotes NF-kB subunits, "sp1" denotes the nucleic acid recognition unit of the SP1 transcription factor, and "TATA" denotes a dimer of the DNA recognition unit of a TATA sequence DNA binding protein (TBP), also known as a TATA binding protein, or TBP. These configurations are further exemplified below and are all integral parts of the instant invention.

In yet another configuration, the modular structure shown in Figure 9 is adapted to detection and or treatment or prophylaxis of a completely different pathogen. In Figure 11, in a similar fashion to the above described "HIV-detect I-IV" molecules, a series of "HPV-Detect I-IV" molecules is produced. In this embodiment, advantage is taken of the DNA binding properties of the E2 protein of human papillomavirus (HPV). In addition, the roles of SP1 and TBP are taken advantage of by providing specific DNA recognition units adapted to bind to these sequences in the HPV genome.

In the formation of the E2-specific TBAs for use in detecting HPV infection, it may be desirable to use any of SEQ ID NOS. 75-84 or 93-98 as the E2 DNA recognition units. A TBA containing a bovine E2 dimer and a human E2 dimer DNA binding domain may be particularly useful.

The various sequences described above may either be chemically linked using pure oligopeptide starting materials, or they may be linked through provision of recombinant nucleic acids encoding, via the well known genetic code, the various subelements. In the event of recombinant production, linking *cro* coding sequences to sequences of nucleic acid recognition units to form TBAs is advantageous because not only does *cro* act as assembly sequences in the chaperone, it also acts to direct the proper folding of the nucleic acid recognition elements. Exemplary sequences for chaperones are provided herein as SEQ ID NOS. 104-108. Furthermore, in the event that higher order structures comprising multiple binding sites is desired, as in a pentameric NF-kB/NF-kB/SP1/SP1/SP1 TBA, proper design of the asymmetry sequences allows such structures to be made.

In the foregoing fashion, TBAs are prepared which bind to their cognate binding sites with high affinity. For example, the NF-kB DNA binding components of the TBAs of Figure 10 are

expected to bind to the HIV-LTR with an affinity of between about 10^{-8} and 10^{-12} molar. Sequences useful as the DNA recognition units are provided as SEQ ID NOS. 63-71, 73-84, 93-98, and 104-108 and exemplified further below.

5 In view of the foregoing description of directed assembly of nucleic acid binding proteins using assembly and asymmetry (or piloting) sequences, those skilled in the art will recognize that a generally applicable method for assembling protein structures is provided by this invention. The generality of this method is demonstrated further by consideration, by way of further example, of the use of an antibody-epitope interaction in the assembly of desired structures. By way of specificity, a DNA binding protein structure may be assembled by linking an NF-kB p50 subunit to an antigen, 10 such as a circularized (through disulfide bonds) melanocyte stimulating hormone (MSH). This pro-MSH molecule may then be bound by an anti-MSH antibody to provide a novel nucleic acid binding assembly, with the antigen and antibody acting as assembly sequences.

The modular structure provided by Figure 9 reveals that a great variety of TBAs may be assembled using different combinations of components. Thus, representative embodiments of this 15 general structure are provided as SEQ ID NOS. 109-116.

20 7. The Booster Binding Assemblies (BBAs) and their preparation. A BBA may be any substance which binds a particular BBR formed by hybridization of particular PNAs and BNAs, including when multiple BNAs (up to and including "n" BNAs, *i.e.*, BNA_n , wherein "n" is theoretically $0-\infty$, but practically is between about 0 and 100) are polymerized onto the PNA for signal amplification, provided that the BBA must have at least the following attributes:

- (a) The BBA must bind the BBRs in a fashion that is highly specific to the BBR of interest. That is, the BBA must discriminate between BBRs present in the PNA-BNA hybrid and similar duplex sequences in BNA-CNA hybrids or other CNAs. Thus, where even a single base mismatch or conformational differences with or without base mismatches occur in the production of the PNA-BNA_n or PNA-BNA_n-HNA hybrid, the BBA must bind the hybrid with a sufficiently low avidity that upon washing the TBA-TNA-PNA-BNA_n complex, the BBA is displaced from the CNA sequences but not the BBR sequences.
- (b) The BBA must avidly bind the BBR(s). Binding affinities in the range of 10^{-5} to about 10^{-9} or higher are generally considered sufficient.
- 30

Examples of BBAs include, but are not limited to *cro*, and the bacteriophage lambda repressor protein, CI. In addition, see U.S. Patent No. 4,556,643, herein incorporated by reference, which suggests other DNA sequences and specific binding proteins such as repressors, histones, DNA modifying enzymes, and catabolite gene activator protein. See also EP 0 453 301, herein

incorporated by reference, which suggests a multitude of nucleotide sequence specific binding proteins (NSSBPs) such as the tetracycline repressor, the lac repressor, and the tryptophan repressor. Each of these BBAs has been recognized in the art to bind to particular, known nucleic acid sequences and the affinities of these interactions are known. Naturally, the method of the instant invention is not limited to the use of these known BBAs. From the instant disclosure, one of ordinary skill could easily apply the use of novel BBAs exhibiting at least the required attributes noted above to the instant method.

Examples of novel BBAs useful according to this aspect of the invention include novel proteins based on the motif of a known DNA or RNA or DNA:RNA binding protein such as *cro* or the λ CI repressor protein. Preferably, such modifications are made to improve the handling of these components of the invention. Thus, it may be desirable to add a high concentration of *cro* to an assay. One of the negative qualities of *cro* is that at high concentrations, the binding of *cro* to its DNA target comes into competition with *cro-cro* interactions. Thus, for example, a chaperoned or mutated *cro* may be produced which does not have this shortcoming. Examples of such altered chaperones are SEQ ID NOS. 105-106 and 108. Methods known in the art, such as production of novel target binding proteins using variegated populations of nucleic acids and selection of bacteriophage binding to particular, pre-selected targets (*i.e.*, so-called phage-display technology, see discussion above for production of novel TBAs) may be used to produce such novel BBAs as well as the aforementioned novel TBAs.

Where the BBA is a protein, or a complex of proteins, it will be recognized that any of a number of methods routine in the art may be used to produce the BBA. The BBA may be isolated from its naturally occurring environment in nature, or if this is impractical, produced by the standard techniques of molecular biology. Thus, for example, the sequence of the *cro* protein is known and any molecular clone of bacteriophage lambda may be used to obtain appropriate nucleic acids encoding *cro* for recombinant production thereof. In addition, the TBAs described herein may be used as BBAs, provided that different TBAs are used to bind TBRs and BBRs.

8. The use of BBAs and BBRs to localize and amplify the localization of the PNA-TNA-TBA complexes (see Figure 8). In one embodiment of this invention, the highly specific and extremely tight binding of TBAs comprised of nucleic acid binding components is used to produce an amplifiable nucleic acid sandwich assay. According to one aspect of this embodiment, a solid support is coated with a first TBA creating an immobilized TBA. In solution, a PNA and TNA are contacted under hybridizing conditions and then contacted with the immobilized TBA. Only those PNA-TNA interactions which form the specific TBR recognized by the immobilized TBA are retained upon wash-out of the solid surface which binds the TBA-TBR complex.

Detection of the bound TBR is accomplished through binding of Booster Nucleic Acids, BNAs, to the 1/2 BBRs present on the PNAs under hybridizing conditions. In this manner, even if only a single TBA-TBR complex is bound to the immobilized TBA, a large, amplified signal may be produced by polymerizing multiple BNAs to the immobilized TNA. Each BNA which binds to the TNA forms a BBR which can be bound by BBAs which, like the TBAs immobilized on the solid surface, may be chosen for their very tight and specific binding to particular nucleic acid structures. Thus, according to this embodiment, the immobilized TBA may contain the DNA binding portion of NF-kB, which very specifically and tightly binds to NF-kB binding sites formed upon hybridization of the TNA and PNA to form such a site.

Because it is well known that there are NF-kB binding sites both in the normal human genome and in the long terminal repeats of human immunodeficiency virus (HIV), this invention provides a method of discriminating between the "normal" human sites and the sites present in cells due to HIV infection. Therefore, in a test designed to determine the presence or absence of HIV DNA in a sample of human DNA, the HIV NF-kB binding sites may be viewed as the TNA, and the normal human NF-kB binding sites may be viewed as CNAs. According to the method of this invention, discrimination between these TNAs and CNAs is accomplished by taking advantage of the fact that in the HIV LTR, there are two NF-kB binding sites, followed by three SPI sites (see, for example, Koken *et al.* [1992] *Virology* 191:968-972), while cellular NF-kB binding sites with the same sequences are not found in tandem.

In cases where the TNA contains more than one 1/2 TBR and it is desirable to pursue the therapeutic and prophylactic applications of the TBAs, it may be desirable to use more than one TBA, each with the capacity to bind a TBR in the TNA-PNA complex. In this case, it may be advantageous to select, as components of the TBAs, DNA-binding or RNA-binding domains with lesser affinity for its TBR than the wild-type DNA-binding or RNA-binding domain. Given that the TBAs which are involved in the binding to the multiple TBRs can either assemble together before binding to their TBRs or assemble together after binding to their TBRs, the individual TBAs will not block the corresponding TBRs in the other genomes than the target genome unless the TBRs are spatially capable of binding the assembled TBA complex. One feature of the multimeric assembly of TBAs which is specifically claimed here as part of this invention is that such a multimeric assembly is expected to have a much reduced affinity for a single site within the TNA. However, since the binding is dramatically increased relative to any one TBA, the TBA complex would be expected to not compete for the binding of any single TBR with the corresponding native proteins *in situ* but bind tightly to sequences in the PNA-TNA hybrid containing the TBRs for each of the nucleic acid-binding components assembled in the TBA. The TBA complex should be assembled

and linkers adjusted in the individual TBAs so as to allow the nucleic acid-binding regions contained in the TBA complex to simultaneously reach and bind to these targets.

Once the TNA-PNA hybrids have formed and been contacted with the immobilized TBA, unbound nucleic acid is washed from the immobilized surface and the immobilized hybrids detected. This is accomplished in any one of several ways. In one aspect of this invention, the PNA is labeled with an OSA, such as a radionuclide, colored beads, or an enzyme capable of forming a colored reaction product. Furthermore, in addition to having one or more 1/2 TBRs, the PNA also may contain at least one 1/2 BBR. The 1/2 BBR sequences are chosen so as to be complementary to unique 1/2 BBR sequences in BNAs. In the embodiment described above, for example, where the TBA is NF-kB and the TBR formed upon TNA-PNA hybridization is one or more NF-kB binding sites, the 1/2 BBRs may provide hybridizable (that is, single-stranded, complementary) sequences of the left or right bacteriophage lambda operators (see, for example, Ptashne [1982] *Scientific American* 247:128-140, and references cited therein for sequences of these operators). These may be polymerized onto the PNA 1/2 BBRs in a vectorial fashion (see Figures 2 and 3) providing up to "n" BBRs, and each BBR forms a *cro* binding site. Enzymatically, radioactively, or otherwise labeled *cro*, is contacted with the TBA-TNA-PNA-(BNA)_n complex. In this fashion, a highly selective and amplified signal is produced. Signal produced using a PNA having a single 1/2 TBR indicates success of the assay in achieving TBA-TBR binding and polymerization of the BNAs to produce signal from cellular sites (i.e. from CNAs). Absence of signal when a dimerized TBA is used indicates that in the TNA, there were no HIV LTRs as no double NF-kB binding sites were present. On the other hand, presence of signal using the dimer NF-kB indicates HIV infection. As a specific example of the foregoing description of this embodiment of the invention, see Example 6 describing an HIV test kit.

Naturally, those skilled in the art will recognize that the foregoing description is subject to several modifications in the choice of PNAs, TNAs, TBAs, BNAs, and BBAs. Furthermore, in systems other than HIV, those skilled in the art will recognize that the general method described above could be likewise applied. However, these other applications may be simpler than the above described method as the TBAs used may not recognize any normal cellular sites and therefore resort to dimerization or other methods of discriminating between TNAs and CNAs may be less critical. In designing probes and binding assemblies for these other systems, the skilled artisan will be guided by the following principles and considerations.

In the above-described embodiment, the appeal of using the DNA-binding portions of NF-kB protein as the TBA and the NF-kB recognition binding elements as the TBRs is that these elements form an important "control point" for the replication of HIV. That is, it is known that HIV

is required to use NF-kB as a critical feature in its replicative life cycle. Similar control points for other pathogens are chosen and used as a basis for detection according to the methods described herein.

5 From the foregoing description of general features of this invention and the mode of its operation, one skilled in the art will recognize that there are a multiplicity of specific modes for practicing this invention. By way of example, the method of this invention is adaptable to a method and devices using chromatographic test kits described in U.S. Patent Nos. 4,690,691 and 5,310,650 (the '691 and '650 patents). In those patents, a porous medium was used to immobilize either a TNA or a capture probe, and a solvent was used to transport a mobile phase containing either a labeled
10 PNA, if the TNA was immobilized, or the TNA, if a capture probe was immobilized, into the "capture zone." Once the TNA was bound in the capture zone, either by directly immobilizing it or through capture, a labeled PNA was chromatographed through the capture zone and any bound label was detected.

Adapting the instant invention to such a system provides the improvement of using a Target
15 Binding Assembly in the capture zone and therefore, the capture of only perfectly matched TBR sequences or other TBRs representing nucleic acid confirmations specifically bound by the TBA within the TNA-PNA duplexes by virtue of the previously described sensitive discrimination by the TBA between TNAs and CNAs.

Once the TNA-PNA hybrids become bound to the immobilized TBA, the signal is amplified
20 by adding BNAs or chromatographing BNAs through the capture zone. Finally, the signal may be further amplified by adding BBAs or chromatographing labeled BBAs through the capture zone. In this fashion, the ease of performing the analysis steps described in the '691 and '650 patents is improved upon herein by providing the additional ability to increase the specificity and, through amplification, the sensitivity of the method described in those patents. The disclosure of the '691
25 and '650 patents is herein incorporated by reference for the purpose of showing the details of that method and for the teachings provided therein of specific operating conditions to which the compositions and methods of the instant invention are adaptable.

Those skilled in the art will also recognize that the method of the instant invention is amenable to being run in microtiter plates or to automation. The use of machines incorporating the
30 method of this invention therefore naturally falls within the scope of the instant disclosure and the claims appended hereto. Thus, for example, this invention is adaptable for use in such instruments as Abbott Laboratories' (Abbott Park, IL) IMx tabletop analyzer. The IMx is currently designed to run both fluorescent polarization immunoassay (FPZA, see Kier [1983] *KCLA* 3:13-15) and microparticle enzyme immunoassay (MEZA, see *Laboratory Medicine*, Vol. 20, No. 1, January

1989, pp. 47-49). The MEZA method is easily transformed into a nucleic acid detection method using the instant invention by using a TBA as a capture molecule coated onto a submicron (<0.5 μm on average) sized microparticle suspended in solution. The microparticles coated with TBA are pipetted into a reaction cell. The IMx then pipettes sample (hybridized PNA-TNA) into the reaction cell, forming a complex with the TBA. After an appropriate incubation period, the solution is transferred to an inert glass fiber matrix for which the particles have a strong affinity and to which the microparticles adhere. Either prior to or after filtering the reaction mixture through the glass fiber matrix, BNAs and BBAs are added, or another signal amplification and detection means is used which depends on specific formation of TNA-PNA hybrids. The immobilized complex is washed and the unbound material flows through the glass fiber matrix.

The bound complexes are detected by means of alkaline phosphatase labeled BBAs or otherwise (radioactively, enzymatically, fluorescently) labeled BBAs. In the case of alkaline phosphatase labeled BBAs, the fluorescent substrate 4-methyl umbelliferyl phosphate or like reagent may be added. Alternatively, the enzyme may be bypassed by directly labeling BBAs with this or a like reagent. In any event, fluorescence or other signal is proportional to the amount of PNA-TNA hybrids present.

The fluorescence is detected on the surface of the matrix by means of a front surface fluorometer as described by the manufacturer of the IMx. With minor adjustments that can be made through routine experimentation to optimize an instrument such as the IMx for nucleic acid hybridization and nucleic acid-TBA interactions, the instant invention is completely adaptable to automated analyses of TNA samples.

9. Other diagnostic applications of this invention. While the foregoing description enables the use of the instant invention in a number of different modes, many additional utilities of this invention are readily appreciated, for example, in a mobility retardation system.

In this embodiment of the invention, an improvement of the well known electrophoretic mobility shift assay (EMSA) is conducted as follows (See Figures 12a and 12b):

A sample of DNA is fragmented, either through random cleavage or through specific restriction endonuclease treatment. The DNA in the sample is then split into two equal aliquots and a specific TNA is added to the first aliquot but not to the second. The first and second aliquot are then electrophoresed in an acrylamide or agarose gel, and the pattern of DNA bands (either visualized through ethidium bromide binding or through being radioactively labeled prior to electrophoresis is then compared for the two aliquots. Fragments of DNA having binding sites to which the TBA is specific are retarded in their migration through the electrophoretic medium. By

using an appropriate TBA, any number of DNA or other nucleic acid sequences may be tracked in this fashion.

5 In a modification of the EMSA described above, fragmented TNA is hybridized with a PNA and fractionated in a first dimension. The fractionated DNA is then reacted with an appropriate TBA and the change in mobility of the DNA fragments is noted. Enhancement of the retardation is possible by adding BBAs as described above. (See, for example, Vijg and references cited therein for known techniques of two (2) dimensional nucleic acid electrophoresis, to which the instant method may be applied).

10 10. Therapeutic applications. Because of the very tight and selective nucleic acid binding characteristics of the novel TBAs described herein, therapeutic utilities are contemplated in addition to the diagnostic utilities of these compounds. Thus, a TBA comprising tight and specific binding for the HIV-LTR, by virtue of having an NF-kB p50 and an SP1 DNA recognition unit in close association (see Figure 10, HIV-Detect II) is useful to bind up the HIV-LTR and thereby prevent transcription from this key element of the HIV genome. The unique features of the assembly
15 sequences of the TBA allow recombinant vectors to introduce DNA encoding such a TBA into a cell and the proper folding of the expressed sequences. Once inside the cell, the nuclear localization signals of the p50 subunit directs the transport of the TBA to the nucleus where it binds tightly to the LTR of any integrated HIV, effectively shutting the pathogen down. In a prophylactic mode, one that is concerned about potential HIV exposure is administered a sufficient dose of a TBA or a
20 recombinant vector able to express the TBA, so as to lock up any HIV that might have entered the person. In this mode, the use of the TBA is analogous to passive protection with a specific immune globulin. In the therapeutic or prophylactic mode, NLS sequences are used in place of the OSAs used in the diagnostic mode. Exemplary NLS sequences are provided as SEQ ID NOS. 72 and 103 (see also Heinzinger 1994 and Bukinsky 1993, describing NLS sequences of the HIV Vpr and gag
25 proteins respectively). In any event, the TBA is administered in a pharmaceutically-acceptable carrier, known in the art such as a sterile salt solution or associated with a liposome or in the form of a recombinant vector, preferably one which directs expression of the TBA in a chosen cell type, or by a protein delivery system.

II. Embodiments of the Invention

30 In view of the foregoing description and the examples which follow, those skilled in the art will appreciate that this disclosure describes and enables various embodiments of this invention, including :

1. A probe nucleic acid (PNA) comprising:

- 5 (a) a single-stranded sequence, 1/2 TBR, which is capable of forming, under hybridizing conditions, a hybrid, TBR, with a 1/2 TBR present in a target nucleic acid (TNA);
- (b) zero, one or more, and preferably one to ten single stranded sequences, 1/2 BBR, which is capable of forming, under hybridizing conditions, a hybrid BBR, with a 1/2 BBR present in a booster nucleic acid (BNA); and
- 10 (c) an OSA, which is no attached support and/or indicator, or an attached support or other means of localization, including, but not limited to, attachment to beads, polymers, and surfaces, and/or indicators;

wherein said TBR is capable of binding with high affinity to a TBA, said TBA being a substance capable of discriminating between a paired TBR and a TBR having unpaired nucleotides, and further, wherein said BBR is capable of binding with high affinity to a BBA, said BBA being a substance capable of discriminating between a paired BBR and a BBR having unpaired nucleotides.

15 This embodiment includes TBRs which are nucleic acid binding protein recognition sites, such as the HIV LTR, and other nucleic acid binding protein recognition sites in other pathogens, some of which are noted above. The PNA of this embodiment of the invention may produce a TBR which is a nucleic acid binding protein recognition site present in the genome of a pathogen or is a binding site associated with a pathogenic condition in the human genome or a contaminant in a fermentation process.

2. A booster nucleic acid (BNA) comprising:

- 20 (a) a 1/2 BBR which has a sequence which is complementary to a 1/2 BBR sequence in a PNA or another BNA already hybridized to the PNA and which is capable of forming, under hybridizing conditions, a hybrid, BBR, with the PNA;
- 25 (b) an OSA attached support or other means of localization, including, but not limited to, attachment to beads, polymers, and surfaces, and/or indicators; and
- (c) additional hybridization sites, 1/2 BBRs, for hybridization with additional BNAs;

wherein said BBR is capable of binding with high affinity to a BBA, said BBA being a substance capable of discriminating between a paired BBR and a BBR having unpaired nucleotides.

30 3. A Hairpin Nucleic Acid (HNA) comprising a single-stranded sequence, 1/2 BBR, which under hybridizing conditions is capable of forming a hairpin while at the same time binding to a BNA to form a BBR capable of binding a BBA, wherein said BBR is capable of binding with high affinity to a BBA, said BBA being a substance capable of discriminating between a paired BBR and a BBR having unpaired nucleotides.

4. A method for detecting a specific TNA sequence, comprising the steps of:

- (a) hybridizing said TNA with a PNA as described above;
- (b) hybridizing said PNA with a BNA containing a 1/2 BBR whose sequence is complementary to a 1/2 BBR sequence in the PNA;
- 5 (c) adding the products of steps (a) and (b) containing a TBR and a BBR, to a surface, liquid or other medium containing a TBA;
- (d) adding BBAs to the mixture in step (c) wherein said BBA comprises:
 - (i) a molecule or a portion of a molecule which is capable of selectively binding to a BBR; and
 - 10 (ii) a detectible indicator;

and

- (e) detecting signal produced by the indicator attached to the BBA. This method includes the use of a protein indicator, including enzymes capable of catalyzing reactions leading to production of colored reaction products. It also includes indicators such as a radionuclide or colored beads.

15

5. A method for detecting the presence in a sample of a specific Target Nucleic Acid, TNA, which comprises:

- (a) contacting said sample with a Probe Nucleic Acid, PNA, which, upon hybridization with said TNA if present in said sample, forms a Target Binding Region, TBR, which is capable of binding a Target Binding Assembly, TBA;
- 20 (b) contacting said sample, already in contact with said PNA, with a TBA capable of binding to any TBRs formed by the hybridization of said PNA and said TNA in the sample.

20

6. A method for detecting or localizing specific nucleic acid sequences with a high degree of sensitivity and specificity which comprises:

25

- (a) adding PNAs containing a 1/2 BBR and a 1/2 TBR to a sample containing or suspected of containing TNAs containing 1/2 TBR sequences, to form a complex having target binding regions, TBRs, formed by the hybridization of complementary 1/2 TBRs present in the PNAs and TNAs respectively;
- 30 (b) binding the TBRs formed in step (a) to an immobilized TBA to form a TBA-TNA-PNA complex;
- (c) adding Booster Nucleic Acids, BNAs, containing booster binding regions, 1/2 BBRs, to the complex formed in step (b) such that the 1/2 BBRs in the BNAs hybridize with the 1/2 BBR sequences present in the PNAs or to 1/2 BBRs present

30

in BNAs already bound to the PNA, to form BBRs, such that TBA-TNA-PNA-(BNA)_n complexes are formed;

- 5
- (d) adding Hairpin Nucleic Acids, HNAs, containing 1/2 BBR sequences, to the complex formed in step (c) such that the 1/2 BBRs in the HNAs hybridize with any available 1/2 BBR sequences present in the BNAs of the complex of step (c), thereby capping the extension of the BNAs onto the TBA-TNA-PNA-(BNA)_n complexes of step (c) to form TBA-TNA-PNA-(BNA)_n-HNA complexes;
- (e) adding Booster Binding Assemblies, BBAs, linked to indicator moieties, to the TBA-TNA-PNA-(BNA)_n-HNA complexes formed in step (d) to form TBA-TNA-PNA-(BNA-BBA)_n-HNA complexes; and
- 10
- (f) detecting the signals produced by the indicator moieties linked to the TBAs, PNAs, BNAs, BBAs or HNAs in the TBA-TNA-PNA-(BNA-BBA)_n-HNA complexes of step (e);

wherein:

15

the TNA comprises:

- (i) one or more specific 1/2 TBR nucleic acid sequences, the presence or absence of which in a particular sample is to be confirmed;

the PNA comprises:

20

- (i) a single-stranded sequence, 1/2 TBR, which is capable of forming, under hybridizing conditions, a hybrid, TBR, with a 1/2 TBR present in a target nucleic acid (TNA);
- (ii) a single stranded sequence, 1/2 BBR, which is capable of forming, under hybridizing conditions, a hybrid BBR with a 1/2 BBR present in a booster nucleic acid (BNA); and
- 25
- (iii) an OSA, which is no attached support and/or indicator, or an attached support or other means of localization, including, but not limited to, attachment to beads, polymers, and surfaces, and/or indicators;

the BNA comprises:

30

- (i) a 1/2 BBR, as shown in Figure 1(IIb), which has a sequence which is complementary to a 1/2 BBR sequence in a PNA and which is capable of forming, under hybridizing conditions, a hybrid, BBR, with the PNA;
- (ii) an OSA attached support or other means of localization, including, but not limited to, attachment to beads, polymers, and surfaces, and/or indicators;
- (iii) additional hybridization sites, 1/2 BBRs, for other BNAs; and

- (iv) sequences, 1/2 BBRs, which can hybridize to BNAs already hybridized to the PNA;

the BBA comprises:

- 5 (i) a molecule or a portion of a molecule which is capable of selectively binding to a BBR; and
- (ii) no attached support and/or indicator, or an attached support or other means of localization, including, but not limited to, attachment to beads, polymers, and surfaces, and/or indicators;

and the TBA comprises:

- 10 (i) a molecule or a portion of a molecule which is capable of selectively binding to a TBR; and
- (ii) no attached support and/or indicator, or an attached support or other means of localization, including, but not limited to, attachment to beads, polymers, and surfaces, and/or indicators.

15 7. An improvement to a solid phase hybridization method for detecting the presence of a target polynucleotide involving: immobilizing a target polynucleotide, if present in a test sample, directly or via an intermediate capture structure, on a solid phase at a capture site; before, during or after said immobilization, attaching a detectable label to said target polynucleotide, if present; and detecting said label, if any, at said capture site; the improvement comprising:

- 20 (a) using a Target Binding Assembly, TBA, as the means for achieving immobilization of said target polynucleotide, wherein said TBA binds only to a perfect hybrid formed between a specific Probe Nucleic Acid, PNA, and said target nucleic acid such that a perfect Target Binding Region, TBR, recognizable by said TBA is formed; and
- 25 (b) including in the PNA a single stranded sequence, 1/2 BBR, capable of binding a Booster Nucleic Acid, BNA, containing a single stranded complementary 1/2 BBR which, upon hybridization with the 1/2 BBR in the PNA, forms a BBR capable of binding labeled Booster Binding Assemblies, BBAs.

30 8. A target binding assembly, TBA, comprising one or more nucleic acid recognition units, linker sequence(s), assembly sequence(s), asymmetry sequence(s), nuclear localization signal sequence(s) (NLS) and OSA(s). The nucleic acid recognition unit may be an NF-kB binding unit, an SP1 binding unit, a TATA binding unit, a human papillomavirus binding unit, an HIV LTR binding unit, or a binding unit for any other fragment of specific sequence the detection of which is desirable and which can be achieved through specific association with the TBA. Such recognition

units include, but are not limited to those exemplified herein as SEQ ID NO. 63, SEQ ID NO. 64, SEQ ID NO. 65, SEQ ID NO. 66, SEQ ID NO. 67, SEQ ID NO. 68, SEQ ID NO. 69, SEQ ID NO. 70, SEQ ID NO. 71, SEQ ID NO. 72, and SEQ ID NO. 73. Linker sequences such as oligopeptides which do not interfere with the nucleic acid recognition function of the nucleic acid recognition unit and which provide stability and control over the spacing of the nucleic acid recognition unit from the remainder of the TBA. Examples of such linker sequences are well known in the art and include, but are not limited to oligopeptide sequences from the interdomain primary sequence of a structural protein. Assembly sequences include oligopeptide sequences which direct the folding and association of nucleic acid recognition units. A preferred example of such sequences are oligopeptides derived from the bacteriophage lambda *cro* protein. The asymmetry sequence directs the association of nucleic acid recognition and assembly sequences in a predetermined order. Such asymmetry sequences are exemplified by sequences derived from insulin, relaxin, gonadotropic hormone, FSH, HCG, LH, ACTH, including but not limited to SEQ ID NOS. 85-92. With reference to Figures 14 and 15, SEQ ID NO. 85 is an "A" and SEQ ID NO. 86 is a "B" sequence; SEQ ID NO. 87 is an "A" and SEQ ID NO. 88 is a "B" sequence; SEQ ID NO. 89 is a human relaxin "A" and SEQ ID NO. 90 is a human relaxin "B" sequence; SEQ ID NO. 91 is a skate relaxin "A" and SEQ ID NO. 92 is a skate relaxin "B" sequence. In addition, the TBA may contain nuclear localization signal sequences, NLS, which direct the migration and uptake of a protein or complex associated with said NLS into the nucleus of a cell. Examples of such NLS sequences are provided as SEQ ID NOS. 72 and 103. Preferred embodiments of the TBA include but are not limited to HIV Detect I-IV or HPV Detect I-IV, and SEQ ID NOS. 109-116.

9. Methods of using the novel TBAs of this invention include, but are not limited to a method of using the TBA to bind a particular nucleic acid sequence in a target nucleic acid sample which comprises:

- (a) fragmenting the nucleic acid in the target nucleic acid sample;
- (b) contacting, under hybridizing conditions, the fragmented nucleic acid with a probe nucleic acid complementary to the particular nucleic acid sequence of interest, wherein said probe nucleic acid, upon hybridization with said particular nucleic acid sequence of interest forms a target binding region to which said TBA specifically binds.

In this method, the probe nucleic acid, in addition to sequences complementary to said particular nucleic acid sequence of interest, also may have additional sequences to which a booster nucleic acid can bind to form a booster binding site to which a labeled booster binding assembly can bind to

provide a signal showing and amplifying the binding of the probe nucleic acid to the target nucleic acid sequence of interest.

An additional aspect of this invention not requiring fragmentation of Target Nucleic Acid, involves administration of the TBA to a patient in need of such treatment of a therapeutically or prophylactically effective amount of said TBA, which comprises administering the TBA, either in the form of a purified protein complex or in the form of a recombinant vector which, upon entry into the patient is able to express the TBA, such that the TBA binds the particular nucleic acid sequence to achieve the desired prophylactic or therapeutic result. This may include providing a dosage which can be determined by routine experimentation to be sufficient to prevent establishment of an active infection by a pathogen. Dosages of purified TBAs may be in the range of about 0.001 to 100 mg/kg. When provided as a recombinant expression vector which will direct the *in vivo* expression and folding of the TBA, dosages of the recombinant nucleic acid may be substantially lower, particularly if provided in the form of non-pathogenic viral vector. The methods of using the TBAs also include monitoring the shift in mobility of nucleic acids in target nucleic acid samples as a function of the size such that binding of the TBA to a particular fragment in the sample modifies the mobility of the fragment. This aspect of the method provides a useful method of analyzing nucleic acid fragments for particular aberrations, such as might be found associated with metastases.

10. Diagnostic or forensic kits useful in determining the presence of an infection, the susceptibility to a disease, or the origin of a particular nucleic acid containing sample.

11. A method of assembling multimeric TBAs *in vivo* which comprises introducing nucleic acids encoding component TBAs into a cell. The component TBAs should each contain a nucleic acid recognition unit, assembly sequences, asymmetry sequences, and nuclear localization signal sequences. Linker sequences, optionally included if TBA footprinting experiments indicate the need for such linkers to attain optimal geometry of the multimeric TBA. Upon *in vivo* expression of each component TBA and proximal binding, via the nucleic acid recognition unit of each component TBA to nucleic acid sequences encountered in the nucleus or elsewhere in the cell, component expressed TBAs are directed to assemble via the included assembly and asymmetry sequences into multimeric TBAs. As described above, such multimeric TBAs will have the advantage of binding specifically with high affinity to TBRs in a specific target sequence, but not at all or with very low affinity to cousin nucleic acids.

The foregoing description of the invention will be appreciated by those skilled in the art to enable preferred embodiments as well as the best mode of this invention. Without limiting the subject matter to the specifics of the examples provided hereinafter, the following examples are

provided to further guide those skilled in the art on methods of practicing this invention. Standard recombinant DNA techniques as disclosed in Sambrook, Fritsch, and Maniatis (1989) *Molecular Cloning: A Laboratory Manual*, 2nd Ed., Cold Spring Harbor Laboratory Press, Cold Spring Harbor, NY, and more recent texts are not disclosed as these are now well within the skill of the ordinary artisan.

5

Example 1 - Preparation of PNAs and Labeling of PNAs

Probe nucleic acids, PNAs, may be prepared by means well known in the art. Thus, single stranded polynucleotide PNAs of defined sequence may be prepared via solid phase chemical synthesis according to Merrifield. PNAs may be prepared by automated synthesis using commercially available technology, such as resins and machines produced or marketed by Applied Biosystems, ABI, or other manufacturers. Alternatively, through known recombinant DNA methods, particular PNA sequences are synthesized *in vivo*, for example by cloning a duplex PNA into a vector which can replicate in *E. coli*, large quantities of the duplex PNA may be prepared. Multimers of the PNA may be cloned into the vector such that for each mole of vector, several moles of PNA is liberated upon digestion of the vector with a restriction fragment flanking the PNA sequence. Subsequent to synthesis or recombinant production, the PNAs are purified by methods well known in the art such as by gel electrophoresis or high pressure liquid chromatography (HPLC). If the PNA is produced as a duplex, prior to use in a hybridization assay for detection of target nucleic acid sequences, the strands of the PNA are separated by heating or other methods known in the art.

10

15

20

The specific sequence of bases in the PNA is chosen to reflect the sequence to be detected in a TNA, with the proviso that, according to this invention, the PNA contains a 1/2 TBR sequence, which is one that upon hybridization of the PNA and TNA, a TBR is formed. As there are an essentially unlimited number of such sequences known in the art, the choice of the PNA sequence is amenable to selection by the skilled researcher for any given application. The sequence of the HIV LTR is one such sequence, which upon hybridization of a PNA encoding portions of the LTR with TNAs encoding the HIV LTR, TBRs capable of binding the NF-kB or SP1 DNA binding proteins are formed.

25

30

In addition to sequences which will form a TBR upon hybridization, the PNA also may contain a 1/2 BBR. This sequence is one which, upon hybridization with a booster nucleic acid, BNA, forms a BBR which is capable of binding a BBA. The BBA is preferably a DNA binding protein having high affinity for the BBR sequence.

In this particular example, hybridization between a PNA having as a 1/2 TBR, SEQ ID NO. 4 and, at the 3' end of that sequence, a 1/2 BBR sequence shown as SEQ ID NO. 35. The PNA encoding these sequences is either used without labeling or is labeled with a radioactive isotope such as P³², S³⁵, or a similar isotope, according to methods known in the art. Alternatively, the PNA is bound to a bead of between 0.01 to 10 μm, which may be colored for easy visual detection. This label forms the OSA as described in the specification. This probe hybridizes with HIV LTR sequences to form a TBR that binds NF-kB. In addition, the PNA hybridizes with BNAs having a complementary 1/2 BBR to form a bacteriophage lambda left operator that binds either *cro* or lambda repressor proteins.

In a manner similar to that described above, PNAs are used wherein the 1/2 TBR is any one of SEQ ID NO. 5 or SEQ ID NOS. 7-34, and a 1/2 BBR, such as SEQ ID NO. 35 or SEQ ID NO. 36 is either at the 3' end or 5' end of the 1/2 TBR.

Example 2 - Preparation and Labeling of BNAs

Similar to the methods described in Example 1 for preparation and labeling of PNAs, BNAs are prepared and labeled according to methods known in the art. As described in U.S. Patent No. 4,556,643, herein incorporated by reference (see particularly Example 1), nucleic acid sequences encoding particular nucleic acid binding sequences may be mass produced by cloning into a replicable vector. Furthermore, similar to that disclosure, the 1/2 TBR and 1/2 BBR sequences may be co-linearly produced in this fashion, with the distinction, however, that according to the instant invention, the 1/2 TBR sequence itself forms a nucleic acid binding component recognition site and the 1/2 BBR, while forming a nucleic acid binding component recognition site, also provides a means of amplifying the signal produced upon binding of the 1/2 TBR to complementary sequences in the TNA by providing for polymerization of BNAs onto the TNA bound PNA. To enable this, a sequence such as SEQ ID NO. 35, which encodes the left operator of bacteriophage lambda, is provided with additional sequences such that an overhang sequence is created on one or both ends of the BNA upon hybridization with the PNA.

As a specific example, vectorial polymerization of BNAs onto a TNA is provided by SEQ ID NOS. 40-43. In this example, SEQ ID NO. 40 encodes two 1/2 TBRs which will hybridize with two 1/2 TBRs in a TNA to form two NF-kB binding sites, while at the same time providing a bacteriophage lambda left operator 1/2 BBR, which additionally is terminated at the 3' end with the recognition site for the restriction enzyme *Pst*I. Addition of the BNA, SEQ ID NO. 41, with the 1/2 BBR complementary to the 1/2 BBR on the PNA, SEQ ID NO. 40, completes the BBR while at the same time completing the *Pst*I recognition site, leaving a four base overhang for hybridization with

additional BNAs. Accordingly, SEQ ID NO. 42 is added which has a four base pair sequence at the 3' end which is complementary to the four-base overhang remaining from the hybridization of SEQ ID NOS. 40 and 41. In addition, SEQ ID NO. 42 is provided with a five base sequence at its 5' end which forms part of a *Bam*HI recognition site. The growing polymer of BNAs is extended further by addition of the BNA SEQ ID NO. 43, which is complementary to SEQ ID NO. 42, completing the BBR while at the same time completing the *Bam*HI recognition site and leaving a four base overhang which may be further hybridized with BNAs having complementary sequences. In this fashion, the BNAs may be hybridized extensively so as to greatly amplify the signal of a single PNA-TNA hybridization event.

As with the PNAs described in Example 1, the BNAs may be used in an unlabeled form or may be labeled according to methods known in the art and described in Example 1. It will also be appreciated that, rather than produce the BNA polymer by sequential addition of BNAs to the PNA-TNA complex, the BNA polymer may be preformed and added directly to the PNA-TNA complex. One simple method for preforming such a BNA polymer includes the recombinant production of a vector in which multimers of the BNA are provided with a unique restriction site at either end of the polymer. This polymer of BNAs containing multiple BBRs is cut out of the vector and hybridizes to a single stranded 1/2 BBR remaining in the PNA upon hybridization of the PNA and the TNA. This is accomplished by providing a single stranded sequence in the PNA complementary to an overhang produced in the BNA polymer when it is excised from the production vector.

Example 3 - Production of HNAs and Their Use for Capping BNA Polymers

The HNAs of this invention are produced according to methods known in the art for polynucleotide production as described in Examples 1 and 2 for PNAs and BNAs. In the production of the HNAs, however, the sequence of the HNA is specifically designed so that a substantial portion of the HNA forms a self-complementary palindrome to form a hairpin, while at the same time, leaving in single stranded form enough bases to be able to hybridize with single stranded sequences in the growing chain of BNAs described in Example 2.

In this Example, a HNA of SEQ ID NO. 44 is provided to cap the extension of BNAs onto the PNA in Example 2 after the addition of the BNA, SEQ ID NO. 43. This is accomplished because SEQ ID NO. 44, while having a palindromic sequence that forms a stable hairpin, also has a sequence at the 5' end of the HNA which completes the *Bam*HI sequence formed by the hybridization of SEQ ID NO. 42 and SEQ ID NO. 43. Naturally, termination of the polymer after addition of only 3 BNAs is for the purpose of simplicity in demonstrating the invention. As described above, this polymerization may be continued essentially indefinitely to amplify the signal

of the PNA-TNA hybridization event. Once the HNA hybridizes to the growing chain of BNAs, the polymer is capped and no further extension of the polymer is possible.

Example 4 - Preparation of TBAs and BBAs, Labeling, and Immobilization Thereof

5 The TBAs and BBAs which may be used according to the instant invention include any substance which can specifically bind to the TBRs and BBRs formed by hybridization of the PNAs, TNAs and BNAs. Use of DNA binding proteins forms one example of such substances.

 For this example, the TBA is the dimer of the DNA binding portion of p50, and the BBA is the lambda *cro* protein. These proteins may be produced according to methods known in the art.
10 The genes for both of these proteins have been cloned. Thus, these proteins are recombinantly produced and purified according to methods known in the art. Furthermore, these proteins are labeled, either with a radioisotope, such as radioactive iodine, or with an enzyme, such as beta-galactosidase or horseradish peroxidase, or with a fluorescent dye such as fluorescein or rhodamine, according to methods well known in the art. In addition, either or both of the TBA and BBA may
15 be immobilized on a solid surface such as the surface of a microtiter plate or the surface of a bead, such as a colored bead of diameter anywhere from 0.01 to 10 μm . The labels on the TBAs and BBAs may be the same or different.

 In this example, the TBA containing the dimeric p50 DNA binding domain is labeled with rhodamine, while the BBA, *cro*, is labeled with fluorescein. Accordingly, upon hybridization of the
20 PNAs, TNAs, BNAs and HNAs as described in this patent disclosure and the foregoing and following examples, the nucleic acid hybrids, if formed, are contacted with excess labeled TBA and *cro*. The fluorescence of these labels is measured according to known methods and, detection of both signals is indicative of the presence of 1/2 TBR sequences in the TNA. The differential signal produced by the fluorescence of the NF-kB and *cro* is a measure of the degree to which the
25 polymerization of BNAs onto the PNA-TBA hybrid has resulted in amplification of the signal. Amplification from one to over a thousand fold is contemplated according to the method of this invention.

30 Example 5 - Hybridization of two PNAs with a TNA and Discrimination Between a TNA and a CNA

 The PNAs, PNA1, SEQ ID NO. 40 and PNA2, SEQ ID NO. 45, are used in about ten-fold molar excess over the concentration of TNAs in a test sample. For this example, an isolated duplex HIV LTR, wherein one strand of which has the sequence SEQ ID NO. 37, shown in Figure 7, and the other strand of which is complementary to the sequence shown in Figure 7, is used as the TNA.

A duplex isolated CNA is also used in this example, one strand of which has the same sequence as SEQ ID NO. 37, except that, in the first NF-kB binding site shown in Figure 7, at the center of the binding site, position 1 in Figure 7, instead of a "T," there is an "A," the complementary strand of which therefore mismatches with the SEQ ID NO. 40 PNA at that location.

5 SEQ ID NO. 40 and SEQ ID NO. 45 are both added to separate reactions, the first containing the above described TNA and the second containing the above described CNA. The samples are solubilized in an appropriate hybridization buffer, such as 10 mM Tris (pH 7.5), 1 mM EDTA. The samples are heated to about 90°C for about five minutes to strand separate the duplex TNAs and CNAs in the samples, and then the samples are allowed to cool to allow strands of PNAs,
10 TNAs and CNAs to anneal.

 Once the hybridization has gone to completion, which can be determined according to known methods such as by calculating the $t_{1/2}$ based on base compositions and annealing temperature according to known methods, the SEQ ID NO. 40 PNA is polymerized by addition of BNAs as in Example 2 and the SEQ ID NO. 45 PNA2 probe is polymerized with BNAs starting with SphI
15 recognition site overhang. Following addition of the BNAs and a brief hybridization period, the separate samples are added to beads coated with covalently immobilized NF-kB, and the NF-kB is allowed to bind to any TBRs formed in the TNA and CNA samples. After about 15 minutes of binding, the samples are washed twice with about three volumes of an appropriate washing buffer, such as 10 mM Tris, pH 7.5, 100 mM NaCl, or another buffer pre-determined not to interfere with
20 NF-kB, or bacteriophage lambda CI repressor protein binding activity. After each wash, the beads are allowed to settle under gravity or by brief centrifugation. This removes any nucleic acids which do not have a perfect NF-kB binding site formed by hybridization of the PNA1 and TNA sequences.

 After the final wash, bacteriophage lambda CI repressor protein labeled with a radioactive isotope, such as with radioactive iodine, or labeled with an enzyme, such as horseradish peroxidase,
25 with colored beads, or with a fluorescent label is added to each sample. The samples are then washed several times (about 3) with several volumes (about 2) of an appropriate washing buffer such as 10 mM Tris, pH 7.5, 100 mM NaCl, or another buffer pre-determined not to interfere with NF-kB, or bacteriophage lambda CI repressor protein binding activity. After each wash, the beads are allowed to settle under gravity or by brief centrifugation. Following the last settling or
30 centrifugation, the bound label is quantitated by detecting the bound radioactivity, liberated color in an enzymatic assay, color of bound beads, or fluorescence detection. Alternatively, an anti-CI antibody can be added and a standard sandwich enzyme linked immunoassay or radioimmunoassay performed to detect bound repressor. In addition, as a negative control (background), all of the

foregoing manipulations are carried out in tandem with a sample in which beads are used having no immobilized NF-kB.

As a result of the foregoing assay, the control and CNA containing samples have similarly low signals while the TNA containing sample has a signal well above background.

5

Example 6 - A Test Kit for the Detection of HIV

A. Kit contents:

1. Microtiter plate.
2. 1 mg/mL solution of recombinantly produced NF-kB in tris-buffered saline.
- 10 3. Tube containing single stranded HIV PNAs (a mixture of pre-mixed oligonucleotides encoding two NF-kB 1/2 binding sites, i.e. a mixture of SEQ. ID. Nos.7 and 8).
4. Tube containing single stranded human genomic PNA, SEQ ID NO. 1.
- 15 5. Tube of nuclease (*Pst*I).
6. Tube of protease.
7. Tube containing pre-polymerized BNA's, 100 repeat units of bacteriophage lambda O_R, capped with an HNA but with free 1/2 BBRs available for binding to PNA-TNA hybrids.
- 20 8. Tube of horseradish peroxidase (hrp) conjugated *cro*.
9. Tube of hrp colored substrate.
10. Tris buffered saline, 100 mL.
11. Lancet.
12. Reaction tubes A, B, C, each containing 250 μ L of distilled water.
- 25 13. Medicine dropper.

B. Assay method:

- (a) The microtiter plate (item 1) is coated with the solution of recombinantly produced NF-kB (item 2) at a concentration of 1 mg/mL in tris buffered saline overnight at 4°C with rocking.
- 30 (b) Three drops of blood of the test taker is obtained by pricking a finger with the lancet (reagent 11), and a drop of blood is dispensed into each of reaction tubes A, B, and C (reagent 12).

- (c) Into each tube is dispensed one drop of protease solution (reagent 6) with the medicine dropper (item 12) and the tube agitated and allowed to sit for 5 minutes.
- (d) One drop of nuclease (item 5) is added to each of tubes A-C using the medicine dropper and the tubes agitated and allowed to sit for 10 minutes.
- 5 (e) One drop of item 3 is added to tube A (test sample); one drop of item 4 is added to tube B (positive control); and one drop of saline (item 12) is added to tube C as a negative control. The tubes are heated to 50°C in hot water and allowed to cool to room temperature over one hour.
- (f) While the hybridization is allowed to occur in step (d), the excess protein is drained from the surface and the microtiter plate, from step (a), and the plate is rinsed with tris buffered saline (tube 10).
- 10 (g) The contents of tubes A-C from step (e) are transferred to three wells of the microtiter plate and allowed to stand for 1 hour with rocking.
- (h) The microtiter wells containing the contents of tubes A-C are rinsed with tris buffered saline and emptied.
- 15 (i) One drop of item 7 is added to each well and allowed to hybridize with any 1/2 BBR sites bound to the plate, over one hour, followed by three rinses with tris buffered saline.
- (j) One drop of item 8 is added to each well and *cro* is allowed to bind to any bound BNA's over 10 minutes, followed by five, one mL washes with tris-buffered saline.
- 20 (k) One drop of hrp substrate is added to each well and color allowed to develop.

C. Results:

If wells A and B both show color development, and well C does not, the test is valid and the subject has been infected with HIV. If only well A shows color development, or if well C shows color development, the test has been performed incorrectly, and is invalid. If wells A and C show no color development but well B does, the test is valid and the individual has not been infected with HIV.

25

30 Example 7 - Production of Various Novel TBAs

Novel TBAs for use according to the instant invention are prepared as follows:

(a) NFkB/NF-kB (HIV-Detect I). A nucleic acid encoding any one of SEQ ID NOS. 63-71 or a like NF-kB DNA binding protein, is fused, in frame, to a nucleotide sequence encoding an assembly sequence, such as *cro*, such that the NF-kB DNA recognition sequence is encoded at amino

or carboxy terminus of the *cro* sequence. Optionally, a linker sequence is provided between the NF-kB sequence and the *cro* sequence. At the other terminus of *cro*, a nuclear localization signal sequence, such as SEQ ID NO. 72, is optionally provided. Further, asymmetry sequences are optionally provided at the *cro* terminus unused by the NF-kB recognition sequence. Examples of complete TBAs are shown below.

5 **(b) NF-kB/SP1 (HIV-Detect II).** In a similar fashion to that described in (a) above, a recombinant coding sequence encoding an NF-kB recognition domain is prepared. In a separate construct, instead of SEQ ID NOS. 63-72, the coding sequence for the DNA recognition portion of SP1 is included. Such a sequence should encode all or a functional part of SEQ ID NO. 73, which
10 is that portion of the SP1 transcription factor exhibiting DNA binding (see Kadonaga *et al.* [1987] *Cell* 51:1079-1090). The NF-kB-encoding vector and the SP1-encoding vector are then co-transfected into an appropriate expression system such as is well known in the art. A monomeric NF-kB recognition unit is added to complete the NF-kB recognition dimer after the assembly of the SP1 and NF-kB recognition units by the chaperone. The asymmetry sequences prevent the formation
15 of NF-kB or SP1 dimers and direct, instead, the formation of NFkB-SP1 heterodimers (*i.e.*, HIV-Detect II), which are then isolated from the expression system (mammalian or bacterial cells) by known methods.

(c) SP1/SP1 TBAs (HIV-Detect III). As described in (b) above, an SP1-encoding TBA construct is prepared. However, only this construct is transfected into the expression system, and
20 asymmetry sequences allowing the formation of SP1-SP1 dimers are included.

(d) SP1-TATA (HIV-Detect IV). As described in (b) above, an SP1-encoding TBA recombinant is produced. In addition, a recombinant encoding a TBA having the binding sequence, SEQ ID NO. 74, or like sequence encoding a TATA recognition unit is prepared with asymmetry sequences complementary to those included in the SP1 TBA-encoding construct. These constructs
25 are co-transfected and the heterodimers isolated by standard methods, including affinity purification on a DNA column having the appropriate SP1-TATA target binding regions.

(e) SP1-E2 (HPV-Detect I). An SP1-encoding construct is prepared as in (b) above. An E2 TBA-encoding construct is prepared by using a sequence encoding any one of SEQ ID NOS. 75-84 and 94-98 which are papillomavirus E2 DNA recognition units (see Hegde *et al.* [1992] *Nature*
30 359:505-512) or like recognition units, is prepared and co-transformed or co-transfected with the SP1 TBA-encoding construct. Monomeric E2 recognition unit is added to the complete E2 recognition dimer after the assembly of the E2-SP1 recognition unit by the chaperone. The heterodimer HPV-Detect I is isolated according to known methods.

(f) E2-E2 (HPV-Detect II). As described above in (e), an E2 TBA-encoding construct is prepared, except that asymmetry sequences are included which permit the formation of E2 dimers. The expressed dimers are then isolated by known methods including affinity for a dimeric E2 binding site on a DNA affinity column.

5 (g) E2-TATA (HPV-Detect III). As described above in (e) and (d), E2 and TATA binding TBAs are prepared (respectively), except that asymmetry sequences are included which enhance the formation of heterodimers rather than homodimers. These constructs are then co-expressed and the heterodimers are isolated.

10 (h) TATA-TATA (HPV-Detect IV). As described above in (a) and (d), a TATA binding TBA-encoding construct is prepared using asymmetry sequences that encourage this homodimer formation and the homodimer is isolated.

(i) Other TBAs. As described above for HIV and HPV TBAs, TBAs for any given pathogen or disease state may be produced by identifying specific DNA binding proteins and forming an expression construct using appropriate linker, assembly, and asymmetry sequences.

15

Example 8

In a similar fashion to the assay described in Example 5, a more stringent assay is produced by using the duplex NF-kB-SP1 binding protein prepared according to Example 6. Accordingly, the probes shown in Figure 7 and used in Example 5 may be lengthened to reduce the interprobe distance and thereby reduce the flexibility of the DNA in the TNA.

20

Example 9 - Production of "High-Order" TBAs

By the appropriate use of asymmetry sequences, TBAs are produced which are dimers, trimers, tetramers, pentamers, or hexamers of particular DNA recognition units. In this fashion, a hexameric TBA is produced by making a first NF-kB p50 dimeric TBA using asymmetry sequences which enable dimer formation. In addition, the asymmetry sequences enable the tetramerization of the p50 dimer with an SP1-SP1 dimer. Finally, additional asymmetry sequences direct the hexamerization with a dimer exhibiting nuclear localization sequences. This is accomplished by incorporating, for example, asymmetry sequences from insulin, which in nature forms hexamers. This hexamer formation is directed by the sequences, SEQ ID NOS. 85 (A) and 86 (B), 87 (A) and 88 (B), 89 (A) and 90 (B), and 91 (A) and 92 (B) (see Figures 13 and 14).

25
30

Because of the extremely high affinity for the HIV-LTR that can be generated using a multimeric TBA, the compounds having this structure and which can be used for this purpose are referred to herein as "HIV-Lock."

5 An optimal HIV-Lock is defined by footprinting (according to methods well known in the art) TBAs bound to TBRs in the HIV LTR to confirm that the binding affinity of each DNA binding protein contributing to the formation of the multimeric TBA complex is downshifted relative to the affinity for any natural target sequence (i.e. CNAs) from which the DNA binding recognition unit of the TBA is derived. Any concomitant loss in binding affinity for the HIV TBRs is more than compensated for upon formation of the multimer as described below.

10 There may be competition between the binding of each component TBA for its TBR and assembly, via asymmetry sequences to form the multimer. This is obviated by adjusting the linkers between the chaperone and asymmetry sequences in each TBA component such that these competing events are uncoupled. The resultant reduction in the dimensionality of diffusion (effective concentration increase) for the TBA asymmetry and assembly components results in efficient formation of the multimeric complex.

15 On the basis of the footprinting, the length and composition of linkers is adjusted to achieve optimal discrimination between target HIV sequences and natural sequences. In this fashion, although each component TBA will have a low affinity for CNA and TBR sequences, the multimeric complex will have an extremely high affinity for the now expanded TBR recognized by the multimeric complex (the square of the affinity of each TBR recognized by each component TBA of the multimeric TBA), while still having a low affinity for CNAs. In the same fashion, other multimeric TBA complexes, aside from HIV-Lock, are prepared.

20 TBAs which can be formed in this fashion include the following sequences, which are assembled by linking either the protein subunits or nucleic acid sequences encoding these subunits, as follows:

<u>Set</u>	<u>Link Sequences from Groups</u>
A	I + II + III
25 B	IV + V + III
C	IV + III

wherein groups I-V consist of sequences selected from:

<u>Group</u>	<u>Selected from Sequences</u>
I	Any of SEQ ID NOS. 85-92
30 II	Met Ser, linked to any of SEQ ID NOS 104-106, each of which is linked to SEQ ID NO. 99.
III	SEQ ID NO. 100 linked to any of SEQ ID NOS. 75-84 or 94-98; SEQ ID NO. 101 linked to either SEQ ID NO. 74 or SEQ ID NO. 93; or SEQ ID

NO. 102 linked to SEQ ID NO. 74 or SEQ ID NO. 93; or any of SEQ ID NO. 72, 103, 73, or 63-71.

IV Any of SEQ ID NOS. 104-106.

V SEQ ID NO. 99.

5 Specific examples of such TBAs are SEQ ID NOS. 109-116, assembled as follows:

	<u>Set</u>	<u>SEQ ID NO.</u>	<u>Link SEQ IDS</u>
	A	109	85 + Met Ser + 104 + 99 + 100 + 94
	A	110	85 + Met Ser + 104 + 99 + 72
	A	111	86 + Met Ser + 105 + 99 + 102 + 74
10	A	112	86 + Met Ser + 106 + 99 + 73
	A	113	89 + Met Ser + 106 + 99 + 63
	C	114	106 + 64
	C	115	105 + 64
	B	116	106 + 99 + 73

15

In this fashion, choosing between appropriate asymmetry sequences, assembly sequences, and DNA recognition units, many different TBAs may be formed. Furthermore, sets of these, such as SEQ ID NOS. 114 and 115, will associate with each other but dimers of SEQ ID NO. 114 or 115 will not form due to charge repulsion in the mutated assembly sequences (SEQ ID NO. 104 is *cro*; SEQ ID NO. 105 is a novel mutated, negatively charged *cro*, and SEQ ID NO. 106 is a novel mutated, positively charged *cro*).

20

Naturally, given the amino acid sequence of these TBAs, one of ordinary skill could produce recombinant nucleic acid clones encoding these, and such recombinant clones naturally form an integral part of this invention.

25

Example 10 - HIV Test Using "HIV-LOCK"

In much the same method as used in Example 6, the "HIV-LOCK" produced according to Example 9 is used as the TBA, reagent 2, with similar results.

30

Example 11 - HIV Test Using "HIV-LOCK" When Testing Blood for Donation

When the quantity of blood to be tested is not limiting, as when samples of blood for donation are to be tested for HIV contamination, tests similar to Example 6 are run, but for each of

tubes A-C, about 5 mL of blood is pelleted in a tabletop centrifuge. Other reagents are scaled up as necessary to handle the larger quantity of TNA present in the sample.

Example 12 - "HIV-LOCK" as an Anti-HIV Therapeutic Agent

5 "HIV-LOCK" produced according to Example 9 is formulated as a 1 mg/mL solution in liposomes and injected intravenously into a subject who has been tested and confirmed to be infected with HIV. A dose of about 0.1 mg to 100 mg of "HIV-LOCK"/kilogram body mass is infused over a twenty-four hour period and the concentration of HIV p24 in the patient's serum monitored. The treatment is repeated as often as necessary, such as when elevations in the serum p24 occur.

10

Example 13 - Use of an HIV-TBA Construct as a Therapeutic

A recombinant retroviral or like vector is used to deliver a construct encoding an HIV-LTR binding TBA to an infected patient. The vector encodes a chaperone, such as *cro*, and sequences DNA for binding portions of p50. The same vector also encodes a chaperone on which an SP1 TBA folds. Asymmetry sequences are provided such that upon co-expression of the p50-TBA and the SP1-TBA in a single HIV infected cell *in vivo*, an immediate association occurs between these TBAs, while at the same time preventing any association between the DNA binding portion of p50 and endogenous p50 or p65 monomers. NLS sequences are also provided in the TBAs so that, upon dimer formation, the TBA immediately relocates to the nucleus of the cell and binds specifically to integrated HIV sequences, thus preventing any transcription from that locus.

15

20

For this purpose, it is desirable to select sequences encoding DNA binding domains such that the expressed monomers are assembled into a TBA which does not bind to natural human sequences. Thus, it is only upon binding of the TBA components to their target sequences that association between all components of the TBA occurs to form a complex which tightly and specifically binds the HIV LTR.

25

Example 14 - Diagnostic Test Kit for Human Papillomavirus

This diagnostic for human papillomavirus takes advantage of the known differential between benign and carcinogenic HPV to provide a test which indicates the susceptibility to malignancy in a patient. The papillomaviruses are a group of small DNA viruses associated with benign squamous epithelial cell tumors in higher vertebrates. At least 27 distinct human types of papillomaviruses (HPVs) have been found; many of these have been associated with specific clinical lesions. Four of these, HPV-6, HPV-11, HPV-16, HPV-18, and HPV-33 have been associated with human genital tract lesions. In general, HPV-6 and HPV-11 DNAs have been found associated with benign lesions

30

of the genital tract. HPV-16, HPV-18, and HPV-33 have also been found associated with premalignant and malignant lesions and are transcribed in most cell lines established from cervical carcinomas. HPV-16, HPV-18, and HPV-33 are likely to be only two members of a large set of HPV DNAs associated with malignant human cervical carcinomas.

5 Animal models have shown that benign papillomavirus lesions can progress to malignant lesions in the presence of a co-carcinogen. HPV DNA has been found in metastases of cervical carcinomas. In malignant cervical lesions, HPV DNA is usually integrated into the human genome, but there may also be extrachromosomal HPV DNA present. Integration of HPV to form the provirus usually results in the disruption of the viral E2 open reading frame (ORF). Despite
10 disruption of the E2 ORF, and examination of cell lines from several cervical carcinomas has shown transcriptionally active and integrated HPV-16 and HPV-18. When HPV-16 genomes which are present in the human cervical carcinoma cell lines SiHa and CaSki have been examined, there are differences found in the integration of HPV-16. In the SiHa line, the single HPV-16 genome integration occurred at bases 3132 and 3384, disrupting the E1 and E2 ORFs with a deletion of 0.3
15 kb. An additional 50-basepair deletion of HPV-16 DNA resulted in the E2 and E4 OFRs being fused. The 5' portion of the HPV-16 DNA, consisting of the disrupted E2 ORF, is ligated to continuous human right flanking sequences. In addition, a single additional guanine is detected at nucleotide 1138 in the middle of the E1 ORF. This basepair addition results in the fusion of the E1a and E1b ORFs to a single E1 ORF.

20 The complete genome of HPV-16 is available on GenBank as accession number K02718; the complete genome of HPV-33 is available on GenBank as accession number M12732; the complete genome of HPV-18 is available on GenBank as accession number X05015.

 As a preliminary screen, the fact of an HPV infection is established for a given cervical biopsy sample by a simple "yes/no" type of analysis using, for example, any or all of the PNAs SEQ
25 ID NOS. 46-53 and an E2 TBA as described above (*i.e.*, fragment DNA, binding the PNA, immobilize with the TBA, and detect signal with BNAs and BBAs).

 Once a biopsy sample is found to be positive for HPV, additional information is obtained as to the malignancy potential of the HPV by analyzing the integration status of the virus in the human genome.

- 30 1. Fragment the DNA in the cervical biopsy sample and hybridize to a blocking probe having the sequence, SEQ ID NO. 60. This probe will bind to all the fragments in the DNA which have not spliced out the 0.3 kb fragment.
2. Expose the DNA in the biopsy sample to a PNA having the sequence, SEQ ID NO. 61. This probe will only bind to fragments which have deleted the 0.3 kb fragment

(the blocking probe will prevent the looping out of the large deletion segments if present).

3. A PNA having SEQ ID NO. 62 is hybridized with SEQ ID NO. 41 to form a BBR which will bind to *cro* or λ CI repressor as a BBA, leaving a single-stranded portion capable of hybridizing with the TATA site on SEQ ID NO. 61. This added to form a TBR on the 5' end of the large deletion.
4. The TBR is immobilized by a TBA having a TATA binding protein DNA recognition unit.
5. The bound fragments are detected by adding BNAs and BBAs as described above.

Detection of signal in this assay indicates that the large fragment is deleted in HPV present in the TNA. Since this deletion is correlated with malignancy, this assay provides insight into the malignancy potential of the HPV infection. This conclusion can be confirmed by performing an analogous assay based on the deletion of the 52-basepair fragment which is also correlated with HPV-induced malignancy.

The TBP recognition unit used in the TBA for this assay may be chosen, for example, from a sequence such as SEQ ID NO. 70 or SEQ ID NO. 93.

Example 15 - Recombinant HIV-LOCK™ Production.

Phase One - Preparation of DNA to Produce the HIV-Lock™. *In vitro* mutagenesis of the coding regions of the naturally occurring, cloned components of the HIV-Lock™ which need to be modified is performed with a MutaGene Phagemid kit. The modified protocol includes the use of a Blue-script plasmid containing each of the binding components of HIV-Lock™. These are transformed into competent cells and uracil-containing phagemids are grown. Single stranded DNA is extracted and used as a template for the mutagenic strand. Oligonucleotides containing the desired mutations, including the incorporation of a novel restriction site, are synthesized and treated with polynucleotide kinase and ATP. The kinase treated oligonucleotides are annealed to the single-stranded template, and a mutagenic strand is synthesized and ligated according to the MutaGene protocol, with the exception that Sequenase 2.0 provides the polymerase. Libraries are screened using both g-³²P end-labeled nucleotides containing sequences complementary to the introduced mutations and by isolating the plasmid DNA and identifying the mutants by the presence of the introduced restriction site. The mutations are also confirmed by sequencing with a Sequenase kit. The HIV-Lock™ DNA is cloned into the baculovirus expression system with a polyhedron promotor.

Phase Two - Production of HIV-Lock™ Proteins Using Baculovirus. Sf-9 cells are cultured to a pre-determined density (about 1×10^6 cells/ml, log phase), infected with the baculovirus

containing the HIV-Lock™ instructions and harvested to recover the recombinant proteins comprising the HIV-Lock™. In the scale-up process, cultures are expanded from flasks to spinners and subsequently to bioreactors. Following infection the cells are harvested at 12, 24, 36 and 48 hours for the protein. Indices of viability are monitored throughout the entire process.

5 **Phase Three - Purification of the HIV-Lock™ Proteins** The harvested proteins are first separated from particulates by flow-through ultracentrifugation to facilitate downstream purification. The centrifuged product is then sterile filtered. Extracts are then centrifuged at 40,000 rpm at 4 °C for 30 minutes and aliquots are immunoprecipitated with polyclonal rabbit antibody against one of the HIV-Lock™ components. Immunoprecipitated proteins are run on an SDS-10% PAGE gel.

10 **Phase Four - Test of HIV-Lock™ Proteins Against HIV DNA** Mobility shift assays are carried out using an oligonucleotide probe comprising elements of the HIV long terminal repeat and fragments containing NFkB binding DNA associated with kappa light chain and microglobulin regulation. The oligonucleotide is annealed to its complimentary strand and end-labeled with g-³²P ATP.

15 Footprinting is accomplished by combining small (10^{-15} M) of radiolabeled HIV LTR DNA with a slightly larger amount of HIV-Lock™ in a buffer at room temperature for 10 minutes. Dithiothreitol is added prior to the addition of protein. Iron (II), EDTA, hydrogen peroxide and sodium ascorbate are added and the reaction mixture is incubated. A quenching agent is added and the products are analyzed using denaturing gel electrophoresis. This is done for different
20 concentrations of protein. The resulting gel is imaged using a phosphoimager scanner and the resulting high resolution image file is analyzed to abstract the binding affinity of HIV-Lock™ for the HIV DNA relative to cellular DNA.

 Multiple design and testing iterations may be used in order to refine binding of HIV-Lock™ and other TBAs for HIV and other organisms. This process makes it possible to design binding
25 assemblies such that the binding assembly is not competitive with the wild type proteins for single binding sites in the genome samples. The development of TBAs for other organisms and TNAs for sequences within these organisms can be made using the aforementioned method. This method is valid when producing binding assemblies for all nucleic acid TBRs including DNA-DNA, DNA-RNA and RNA-RNA hybrids and combinations of these hybrids.

30

Example 16 - Method for identifying nucleic acid binding molecules for production of TBAs and BBAs of the invention:

 In the method of this invention, target binding assemblies and booster binding assemblies are assembled by identifying nucleic acid binding molecules, and linking the nucleic acid binding

portions of the molecules in such a fashion as to achieve TBAs which discriminate between particular target sequences and even closely related sequences. One method for identifying the nucleic acid binding molecules involves the following steps:

1. Obtaining a biological sample containing the target nucleic acid. This could be, for example, an organism or a tissue extract infected with a pathogen.
2. Fragmenting the sample so as to expose the nucleic acids and to reduce the size complexity of the nucleic acids contained in the sample.
3. Contacting a first aliquot of the fragmented nucleic acids with a control buffer medium and contacting a second aliquot of the fragmented nucleic acids with the control buffer medium containing a known profile of nucleic acid binding molecules.
4. Analyzing the two aliquots to identify fragments which have altered behavior in the aliquot contacted with the target binding molecules as opposed to the control aliquot. This is accomplished by single dimension gel electrophoresis, two dimension gel electrophoresis, high performance liquid chromatography, paper chromatography or any other means which reveals a different behavior of the nucleic acid fragments when bound to a nucleic acid binding molecule as opposed to when the nucleic acid fragment is unbound.
5. Identifying and isolating fragments which do exhibit altered behavior when contacted with the nucleic acid binding molecule and either sequencing the nucleic acid fragment to determine whether known nucleic acid binding molecule motifs are present, or directly identifying the nucleic acid binding molecule bound to the nucleic acid. The latter can be achieved, for example, by contacting a two dimensional grid of the electrophoresed nucleic acids with differentially labeled antibodies which bind to the various nucleic acid binding molecules.

In this method, preferably nucleic acid motifs are used for either diagnostic or therapeutic purposes wherein the target nucleic acid has more than a single utilizable nucleic acid binding molecule target. In this way, a complex target binding assembly can be generated which takes advantage of the proximity of different nucleic acid binding molecular motifs to enhance the specificity of the TBA assembled from the individual nucleic acid binding components identified. The various nucleic acid binding portions of the nucleic acid binding molecules are then assembled into the complete TBAs as described above, for example, for HIV-LOCK™.

Example 17 - Method of identifying specific RNA sequences in a sample

According to the methods and compositions taught in this invention, any nucleic acid sequence can be specifically identified. Identification of target HIV RNA in a sample is achieved

by obtaining a sample of a patient's blood or other biological fluid or extract which may contain the HIV RNA, and testing for the presence of TAR binding sites. Tat is a positive regulator of HIV replication which binds to the TAR region of the HIV RNA. The smallest naturally occurring, fully active form of HIV-Tat is 72 amino acids in length, SEQ Id. 118 herein. Tat contains at least two functional domains, and transactivates gene expression from the HIV long terminal repeat (HIV LTR). Tat binds to an RNA stem loop structure formed from the self-hybridization of sequences in TAR, which is just 5' to the HIV LTR. HIV TAR RNA forms a dinucleotide bulge and two stem-loop structures (Rhim et al. 1994 Virology:202, 202-211). The Tat (SEQ. Id. 118) binds to this structure with lower avidity than does Tat variants wherein Ala58 is a threonine or where His65 is an Asp residue. (Derse et al., 1993 Virology:194,530-536). Utilizing these facts in the instant method is accomplished by:

1. Fragmenting a biological sample to expose the nucleic acids and reduce the size complexity of the nucleic acids.
2. Contacting a TBA with the sample which identifies a hybrid TAR binding protein sequence and a proximate flanking sequence in the HIV genome. The TBA used for this purpose is assembled on *cro* as the chaperone using Tat as the HIV RNA specific binding molecule. To provide specificity such that cross-talk between the HIV TAR site and closely related TAR sites which may be present due to such other pathogens as cytomegalovirus, the TBA also has an antibody component which recognizes the DNA-RNA hybrid target binding region formed when a probe nucleic acid binds to the HIV LTR RNA.
3. Eliminating any "cross-talk" produced by binding of Tat to the TAR region of the HIV RNA due to such contaminants (cousin RNAs) as the CMV TAR sequence by contacting the reaction with excess Tat variant (either the Ala58 to Thr or the His65 to Asp variants) which bind more avidly. In this way, single binding events due to the TBA binding to a cousin RNAs are competed from the nucleic acid sample by the Tat variant. On the other hand, by appropriately selecting the affinity of the double binding achieved as a result of the antibody and Tat, the TBA is not displaced from true targets. This process is illustrated in figure 16. In another aspect of this same method, the TBA could be one in which, rather than using a variant of Tat, an antibody is used which recognizes this nucleic acid segment, and the TBA used is a double antibody TBA.

In an alternate version of this method, a probe nucleic acid may be used which hybridizes with the HIV LTR RNA. Accordingly, a duplex segment of the LTR sp1 sites can be created as part of the target binding region. This region of the HIV RNA flanks the TAR region which is 5' to the LTR but is in close proximity thereto. A TBA containing Tat and two Sp1 binding units is

chaperoned to provide Tat binding to TAR and Sp1 binding to the Sp1 binding sites. Amplification and detection is then carried out by adding appropriate BNAs, BBAs and HNAs. In yet another alternative, PNAs having Seq. ID. 38 and Seq. ID. 39 (see figure 7) could be used. A TBA is used which contains one or more Sp1 binding units and an antibody unit which binds to the DNA-RNA hybrid produced from sample RNA and the Seq. Id. 38 PNA. Appropriate BNAs, BBAs and HNAs are then added to amplify the signal.

Naturally, those skilled in the art will recognize that other TBA and TNA combinations could be used to optimize the methods exemplified herein.

It should be understood that the examples and embodiments described herein are for illustrative purposes only and that various modifications or changes in light thereof will be suggested to persons skilled in the art and are to be included within the spirit and purview of this application and the scope of the appended claims. It will be understood that sequences provided herein are exemplary only and that other like sequences suggested by these could be used in the methods of this invention. It will also be understood that although any sequence provided herein might be designated as linear, it could be used in a circularly or otherwise permuted form and although designated as not being anti-sense, it could be used in the coding or non-coding form or to bind to coding or non-coding complementary sequences.

SEQUENCE LISTING

(1) GENERAL INFORMATION:

(i) APPLICANT:

Applicant Name(s): THE GENE POOL, INC.
Street address: 300 Queen Anne Ave. N., Suite 392
City: Seattle
State/Province: Washington
Country: US
Postal code/Zip: 98109-4599
Phone number: (206) 526-8617 Fax number:

(ii) TITLE OF INVENTION: METHOD OF DETECTION OF NUCLEIC ACIDS WITH A SPECIFIC SEQUENCE COMPOSITION

(iii) NUMBER OF SEQUENCES: 118

(iv) CORRESPONDENCE ADDRESS:

(A) ADDRESSEE: Saliwanchik & Saliwanchik
(B) STREET: 2421 N.W. 41st St., Suite A-1
(C) CITY: Gainesville
(D) STATE: Florida
(E) COUNTRY: USA
(F) ZIP: 32606

(v) COMPUTER READABLE FORM:

(A) MEDIUM TYPE: Floppy disk
(B) COMPUTER: IBM PC compatible
(C) OPERATING SYSTEM: PC-DOS/MS-DOS
(D) SOFTWARE: PatentIn Release #1.0, Version #1.25

(vi) CURRENT APPLICATION DATA:

(A) APPLICATION NUMBER:
(B) FILING DATE:
(C) CLASSIFICATION:

(viii) ATTORNEY/AGENT INFORMATION:

(A) NAME: Bencen, Gerard H
(B) REGISTRATION NUMBER: 35,746
(C) REFERENCE/DOCKET NUMBER: GP-100.c1

(ix) TELECOMMUNICATION INFORMATION:

(A) TELEPHONE: (904) 375-8100
(B) TELEFAX: (904) 372-5800

(2) INFORMATION FOR SEQ ID NO:1:

(i) SEQUENCE CHARACTERISTICS:

(A) LENGTH: 13 base pairs
(B) TYPE: nucleic acid
(C) STRANDEDNESS: both
(D) TOPOLOGY: linear

64

- (ii) MOLECULE TYPE: cDNA
- (iii) HYPOTHETICAL: NO
- (iv) ANTI-SENSE: NO
- (xi) SEQUENCE DESCRIPTION: SEQ ID NO:1:

TGGGGATTCC CCA

13

(2) INFORMATION FOR SEQ ID NO:2:

- (i) SEQUENCE CHARACTERISTICS:
 - (A) LENGTH: 13 base pairs
 - (B) TYPE: nucleic acid
 - (C) STRANDEDNESS: both
 - (D) TOPOLOGY: linear
- (ii) MOLECULE TYPE: cDNA
- (iii) HYPOTHETICAL: NO
- (iv) ANTI-SENSE: NO
- (xi) SEQUENCE DESCRIPTION: SEQ ID NO:2:

AAGGGACTTT CCC

13

(2) INFORMATION FOR SEQ ID NO:3:

- (i) SEQUENCE CHARACTERISTICS:
 - (A) LENGTH: 13 base pairs
 - (B) TYPE: nucleic acid
 - (C) STRANDEDNESS: both
 - (D) TOPOLOGY: linear
- (ii) MOLECULE TYPE: cDNA
- (iii) HYPOTHETICAL: NO
- (iv) ANTI-SENSE: NO
- (xi) SEQUENCE DESCRIPTION: SEQ ID NO:3:

AGGGGACTTT CCG

13

(2) INFORMATION FOR SEQ ID NO:4:

- (i) SEQUENCE CHARACTERISTICS:
 - (A) LENGTH: 15 base pairs
 - (B) TYPE: nucleic acid
 - (C) STRANDEDNESS: both
 - (D) TOPOLOGY: linear

- (ii) MOLECULE TYPE: cDNA
- (iii) HYPOTHETICAL: NO
- (iv) ANTI-SENSE: NO
- (xi) SEQUENCE DESCRIPTION: SEQ ID NO:4:

GCTGGGGACT TTCCA

15

(2) INFORMATION FOR SEQ ID NO:5:

- (i) SEQUENCE CHARACTERISTICS:
 - (A) LENGTH: 15 base pairs
 - (B) TYPE: nucleic acid
 - (C) STRANDEDNESS: both
 - (D) TOPOLOGY: linear
- (ii) MOLECULE TYPE: cDNA
- (iii) HYPOTHETICAL: NO
- (iv) ANTI-SENSE: NO
- (xi) SEQUENCE DESCRIPTION: SEQ ID NO:5:

ACAAGGGACT TTCCG

15

(2) INFORMATION FOR SEQ ID NO:6:

- (i) SEQUENCE CHARACTERISTICS:
 - (A) LENGTH: 13 base pairs
 - (B) TYPE: nucleic acid
 - (C) STRANDEDNESS: both
 - (D) TOPOLOGY: linear
- (ii) MOLECULE TYPE: cDNA
- (iii) HYPOTHETICAL: NO
- (iv) ANTI-SENSE: NO
- (xi) SEQUENCE DESCRIPTION: SEQ ID NO:6:

CCGGGTTTTTC CCC

13

(2) INFORMATION FOR SEQ ID NO:7:

- (i) SEQUENCE CHARACTERISTICS:
 - (A) LENGTH: 27 base pairs
 - (B) TYPE: nucleic acid
 - (C) STRANDEDNESS: both
 - (D) TOPOLOGY: linear

- (ii) MOLECULE TYPE: cDNA
- (iii) HYPOTHETICAL: NO
- (iv) ANTI-SENSE: NO
- (xi) SEQUENCE DESCRIPTION: SEQ ID NO:7:

AAGGGACTTT CCGCTGGGGA CTTTCCA

27

(2) INFORMATION FOR SEQ ID NO:8:

- (i) SEQUENCE CHARACTERISTICS:
 - (A) LENGTH: 27 base pairs
 - (B) TYPE: nucleic acid
 - (C) STRANDEDNESS: both
 - (D) TOPOLOGY: linear
- (ii) MOLECULE TYPE: cDNA
- (iii) HYPOTHETICAL: NO
- (iv) ANTI-SENSE: NO
- (xi) SEQUENCE DESCRIPTION: SEQ ID NO:8:

AAGGGACTTT CCGCTGGGGA CTTTCCG

27

(2) INFORMATION FOR SEQ ID NO:9:

- (i) SEQUENCE CHARACTERISTICS:
 - (A) LENGTH: 26 base pairs
 - (B) TYPE: nucleic acid
 - (C) STRANDEDNESS: both
 - (D) TOPOLOGY: linear
- (ii) MOLECULE TYPE: cDNA
- (iii) HYPOTHETICAL: NO
- (iv) ANTI-SENSE: NO
- (xi) SEQUENCE DESCRIPTION: SEQ ID NO:9:

GCTGGGGACT TTCCAGGGAG GCGTGG

26

(2) INFORMATION FOR SEQ ID NO:10:

- (i) SEQUENCE CHARACTERISTICS:
 - (A) LENGTH: 26 base pairs
 - (B) TYPE: nucleic acid
 - (C) STRANDEDNESS: both
 - (D) TOPOLOGY: linear

67

(ii) MOLECULE TYPE: cDNA

(iii) HYPOTHETICAL: NO

(iv) ANTI-SENSE: NO

(xi) SEQUENCE DESCRIPTION: SEQ ID NO:10:

GCTGGGGACT TTCCAGGGGA GGTGTG

26

(2) INFORMATION FOR SEQ ID NO:11:

- (i) SEQUENCE CHARACTERISTICS:
(A) LENGTH: 26 base pairs
(B) TYPE: nucleic acid
(C) STRANDEDNESS: both
(D) TOPOLOGY: linear

(ii) MOLECULE TYPE: cDNA

(iii) HYPOTHETICAL: NO

(iv) ANTI-SENSE: NO

(xi) SEQUENCE DESCRIPTION: SEQ ID NO:11:

GCTGGGGACT TTCCGGGGAG CGTGCC

26

(2) INFORMATION FOR SEQ ID NO:12:

- (i) SEQUENCE CHARACTERISTICS:
(A) LENGTH: 26 base pairs
(B) TYPE: nucleic acid
(C) STRANDEDNESS: both
(D) TOPOLOGY: linear

(ii) MOLECULE TYPE: cDNA

(iii) HYPOTHETICAL: NO

(iv) ANTI-SENSE: NO

(xi) SEQUENCE DESCRIPTION: SEQ ID NO:12:

GCTGGGGACT TTCCGGGGAG GCGCGG

26

(2) INFORMATION FOR SEQ ID NO:13:

- (i) SEQUENCE CHARACTERISTICS:
(A) LENGTH: 26 base pairs
(B) TYPE: nucleic acid
(C) STRANDEDNESS: both

(D) TOPOLOGY: linear

(ii) MOLECULE TYPE: cDNA

(iii) HYPOTHETICAL: NO

(iv) ANTI-SENSE: NO

(xi) SEQUENCE DESCRIPTION: SEQ ID NO:13:

GCTGGGGACT TTCCAGAGAG GCGTGG

26

(2) INFORMATION FOR SEQ ID NO:14:

(i) SEQUENCE CHARACTERISTICS:

(A) LENGTH: 26 base pairs

(B) TYPE: nucleic acid

(C) STRANDEDNESS: both

(D) TOPOLOGY: linear

(ii) MOLECULE TYPE: cDNA

(iii) HYPOTHETICAL: NO

(iv) ANTI-SENSE: NO

(xi) SEQUENCE DESCRIPTION: SEQ ID NO:14:

GCTGGGGACT TTCCAGGGGA GCGGTG

26

(2) INFORMATION FOR SEQ ID NO:15:

(i) SEQUENCE CHARACTERISTICS:

(A) LENGTH: 26 base pairs

(B) TYPE: nucleic acid

(C) STRANDEDNESS: both

(D) TOPOLOGY: linear

(ii) MOLECULE TYPE: cDNA

(iii) HYPOTHETICAL: NO

(iv) ANTI-SENSE: NO

(xi) SEQUENCE DESCRIPTION: SEQ ID NO:15:

GCTGGGGACT TTCCAGGGAG GCGTGG

26

(2) INFORMATION FOR SEQ ID NO:16:

(i) SEQUENCE CHARACTERISTICS:

(A) LENGTH: 26 base pairs

(B) TYPE: nucleic acid

69

- (C) STRANDEDNESS: both
- (D) TOPOLOGY: linear

(ii) MOLECULE TYPE: cDNA

(iii) HYPOTHETICAL: NO

(iv) ANTI-SENSE: NO

(xi) SEQUENCE DESCRIPTION: SEQ ID NO:16:

GCTGGGGACT TTCCAGGGAG GCTGCC

26

(2) INFORMATION FOR SEQ ID NO:17:

- (i) SEQUENCE CHARACTERISTICS:
 - (A) LENGTH: 33 base pairs
 - (B) TYPE: nucleic acid
 - (C) STRANDEDNESS: both
 - (D) TOPOLOGY: linear

(ii) MOLECULE TYPE: cDNA

(iii) HYPOTHETICAL: NO

(iv) ANTI-SENSE: NO

(xi) SEQUENCE DESCRIPTION: SEQ ID NO:17:

TTTCCAGGGA GCGTGGCCT GGGCGGGACT GGG

33

(2) INFORMATION FOR SEQ ID NO:18:

- (i) SEQUENCE CHARACTERISTICS:
 - (A) LENGTH: 33 base pairs
 - (B) TYPE: nucleic acid
 - (C) STRANDEDNESS: both
 - (D) TOPOLOGY: linear

(ii) MOLECULE TYPE: cDNA

(iii) HYPOTHETICAL: NO

(iv) ANTI-SENSE: NO

(xi) SEQUENCE DESCRIPTION: SEQ ID NO:18:

CGTGGCCTGG GCGGGACTGG GGAGTGGCGT CCC

33

(2) INFORMATION FOR SEQ ID NO:19:

- (i) SEQUENCE CHARACTERISTICS:
 - (A) LENGTH: 45 base pairs
 - (B) TYPE: nucleic acid

- (C) STRANDEDNESS: both
- (D) TOPOLOGY: linear

(ii) MOLECULE TYPE: cDNA

(iii) HYPOTHETICAL: NO

(iv) ANTI-SENSE: NO

(xi) SEQUENCE DESCRIPTION: SEQ ID NO:19:

CTACAAGGGA CTTTCCGCTG GGGACTTTC AGGGAGGCGT GGCCT

45

(2) INFORMATION FOR SEQ ID NO:20:

- (i) SEQUENCE CHARACTERISTICS:
 - (A) LENGTH: 46 base pairs
 - (B) TYPE: nucleic acid
 - (C) STRANDEDNESS: both
 - (D) TOPOLOGY: linear

(ii) MOLECULE TYPE: cDNA

(iii) HYPOTHETICAL: NO

(iv) ANTI-SENSE: NO

(xi) SEQUENCE DESCRIPTION: SEQ ID NO:20:

CAGCAAGGGA CTTTCCGCTG GGGACTTTC AGGGGAGGTG TGGCCT

46

(2) INFORMATION FOR SEQ ID NO:21:

- (i) SEQUENCE CHARACTERISTICS:
 - (A) LENGTH: 46 base pairs
 - (B) TYPE: nucleic acid
 - (C) STRANDEDNESS: both
 - (D) TOPOLOGY: linear

(ii) MOLECULE TYPE: cDNA

(iii) HYPOTHETICAL: NO

(iv) ANTI-SENSE: NO

(xi) SEQUENCE DESCRIPTION: SEQ ID NO:21:

CATCAAGGGA CTTTCCGCTG GGGACTTTC AGGGGAGGTG TGGCCT

46

(2) INFORMATION FOR SEQ ID NO:22:

- (i) SEQUENCE CHARACTERISTICS:
 - (A) LENGTH: 46 base pairs
 - (B) TYPE: nucleic acid

- (C) STRANDEDNESS: both
- (D) TOPOLOGY: linear

(ii) MOLECULE TYPE: cDNA

(iii) HYPOTHETICAL: NO

(iv) ANTI-SENSE: NO

(xi) SEQUENCE DESCRIPTION: SEQ ID NO:22:

CAACAAGGGA CTTTCCGCTG GGGACTTTC AGGGGAGGTG TGGCCT

46

(2) INFORMATION FOR SEQ ID NO:23:

- (i) SEQUENCE CHARACTERISTICS:
 - (A) LENGTH: 45 base pairs
 - (B) TYPE: nucleic acid
 - (C) STRANDEDNESS: both
 - (D) TOPOLOGY: linear

(ii) MOLECULE TYPE: cDNA

(iii) HYPOTHETICAL: NO

(iv) ANTI-SENSE: NO

(xi) SEQUENCE DESCRIPTION: SEQ ID NO:23:

CTACAAGGGA CTTTCCGCTG GGGACTTTC AGGGAGGCGT GGCAT

45

(2) INFORMATION FOR SEQ ID NO:24:

- (i) SEQUENCE CHARACTERISTICS:
 - (A) LENGTH: 44 base pairs
 - (B) TYPE: nucleic acid
 - (C) STRANDEDNESS: both
 - (D) TOPOLOGY: linear

(ii) MOLECULE TYPE: cDNA

(iii) HYPOTHETICAL: NO

(iv) ANTI-SENSE: NO

(xi) SEQUENCE DESCRIPTION: SEQ ID NO:24:

CTACAAGGGA CTTTCCGCTG GGGACTTTC GGGGAGCGTG GCCT

44

(2) INFORMATION FOR SEQ ID NO:25:

- (i) SEQUENCE CHARACTERISTICS:
 - (A) LENGTH: 44 base pairs

- (B) TYPE: nucleic acid
- (C) STRANDEDNESS: both
- (D) TOPOLOGY: linear

(ii) MOLECULE TYPE: cDNA

(iii) HYPOTHETICAL: NO

(iv) ANTI-SENSE: NO

(xi) SEQUENCE DESCRIPTION: SEQ ID NO:25:

CTACAAGGGA CTTTCCGCTG GGGACTTTCC GGGGAGGCGC GGCT

44

(2) INFORMATION FOR SEQ ID NO:26:

- (i) SEQUENCE CHARACTERISTICS:
 - (A) LENGTH: 45 base pairs
 - (B) TYPE: nucleic acid
 - (C) STRANDEDNESS: both
 - (D) TOPOLOGY: linear

(ii) MOLECULE TYPE: cDNA

(iii) HYPOTHETICAL: NO

(iv) ANTI-SENSE: NO

(xi) SEQUENCE DESCRIPTION: SEQ ID NO:26:

CTACAAGGGA CTTTCCGCTG GGGACTTTCC AGAGAGGCGT GGACT

45

(2) INFORMATION FOR SEQ ID NO:27:

- (i) SEQUENCE CHARACTERISTICS:
 - (A) LENGTH: 46 base pairs
 - (B) TYPE: nucleic acid
 - (C) STRANDEDNESS: both
 - (D) TOPOLOGY: linear

(ii) MOLECULE TYPE: cDNA

(iii) HYPOTHETICAL: NO

(iv) ANTI-SENSE: NO

(xi) SEQUENCE DESCRIPTION: SEQ ID NO:27:

CTACAAGGGA CTTTCCGCTG GGGACTTTCC AGGGGAGGCG TGGACT

46

(2) INFORMATION FOR SEQ ID NO:28:

- (i) SEQUENCE CHARACTERISTICS:

73

- (A) LENGTH: 46 base pairs
- (B) TYPE: nucleic acid
- (C) STRANDEDNESS: both
- (D) TOPOLOGY: linear

(ii) MOLECULE TYPE: cDNA

(iii) HYPOTHETICAL: NO

(iv) ANTI-SENSE: NO

(xi) SEQUENCE DESCRIPTION: SEQ ID NO:28:

CTACAGGGGA CTTTCCGCTG GGGACTTCC AGGGAGGCGT GGGGAG

46

(2) INFORMATION FOR SEQ ID NO:29:

- (i) SEQUENCE CHARACTERISTICS:
 - (A) LENGTH: 43 base pairs
 - (B) TYPE: nucleic acid
 - (C) STRANDEDNESS: both
 - (D) TOPOLOGY: linear

(ii) MOLECULE TYPE: cDNA

(iii) HYPOTHETICAL: NO

(iv) ANTI-SENSE: NO

(xi) SEQUENCE DESCRIPTION: SEQ ID NO:29:

CTACAGGGGA CTTTCCGCTG GGGACTTCC AGGGAGGCTG CCT

43

(2) INFORMATION FOR SEQ ID NO:30:

- (i) SEQUENCE CHARACTERISTICS:
 - (A) LENGTH: 48 base pairs
 - (B) TYPE: nucleic acid
 - (C) STRANDEDNESS: both
 - (D) TOPOLOGY: linear

(ii) MOLECULE TYPE: cDNA

(iii) HYPOTHETICAL: NO

(iv) ANTI-SENSE: NO

(xi) SEQUENCE DESCRIPTION: SEQ ID NO:30:

CTTTCCGCTG GGGACTTCC AGGGAGGCGT GGCCTGGGCG GGA CTGGG

48

(2) INFORMATION FOR SEQ ID NO:31:

- (i) SEQUENCE CHARACTERISTICS:

- (A) LENGTH: 45 base pairs
- (B) TYPE: nucleic acid
- (C) STRANDEDNESS: both
- (D) TOPOLOGY: linear

(ii) MOLECULE TYPE: cDNA

(iii) HYPOTHETICAL: NO

(iv) ANTI-SENSE: NO

(xi) SEQUENCE DESCRIPTION: SEQ ID NO:31:

TTTCCAGGGA GCGTGGCCT GGGCGGGACT GGGGAGTGGC GTCCC

45

(2) INFORMATION FOR SEQ ID NO:32:

- (i) SEQUENCE CHARACTERISTICS:
 - (A) LENGTH: 59 base pairs
 - (B) TYPE: nucleic acid
 - (C) STRANDEDNESS: both
 - (D) TOPOLOGY: linear

(ii) MOLECULE TYPE: cDNA

(iii) HYPOTHETICAL: NO

(iv) ANTI-SENSE: NO

(xi) SEQUENCE DESCRIPTION: SEQ ID NO:32:

CTACAAGGGA CTTTCCGCTG GGGACTTTCC AGGGAGGCGT GGCCTGGGCG GGACTGGGG

59

(2) INFORMATION FOR SEQ ID NO:33:

- (i) SEQUENCE CHARACTERISTICS:
 - (A) LENGTH: 59 base pairs
 - (B) TYPE: nucleic acid
 - (C) STRANDEDNESS: both
 - (D) TOPOLOGY: linear

(ii) MOLECULE TYPE: cDNA

(iii) HYPOTHETICAL: NO

(iv) ANTI-SENSE: NO

(xi) SEQUENCE DESCRIPTION: SEQ ID NO:33:

TTTCCGCTGG GGACTTTCCA GGGAGGCGTG GCCTGGGCGG GACTGGGGAG TGGCGTCCC

59

(2) INFORMATION FOR SEQ ID NO:34:

- (i) SEQUENCE CHARACTERISTICS:

75

- (A) LENGTH: 70 base pairs
- (B) TYPE: nucleic acid
- (C) STRANDEDNESS: both
- (D) TOPOLOGY: linear

(ii) MOLECULE TYPE: cDNA

(iii) HYPOTHETICAL: NO

(iv) ANTI-SENSE: NO

(xi) SEQUENCE DESCRIPTION: SEQ ID NO:34:

CTACAAGGGA CTTTCCGCTG GGGACTTTC AGGGAGGCGT GGCCTGGGCG GGACTGGGGA 60
GTGGCGTCCC 70

(2) INFORMATION FOR SEQ ID NO:35:

- (i) SEQUENCE CHARACTERISTICS:
 - (A) LENGTH: 61 base pairs
 - (B) TYPE: nucleic acid
 - (C) STRANDEDNESS: both
 - (D) TOPOLOGY: linear

(ii) MOLECULE TYPE: cDNA

(iii) HYPOTHETICAL: NO

(iv) ANTI-SENSE: NO

(xi) SEQUENCE DESCRIPTION: SEQ ID NO:35:

TATCACCGCC AGTGGTATTT ATGTCAACAC CGCCAGAGAT AATTTATCAC CGCAGATGGT 60
T 61

(2) INFORMATION FOR SEQ ID NO:36:

- (i) SEQUENCE CHARACTERISTICS:
 - (A) LENGTH: 64 base pairs
 - (B) TYPE: nucleic acid
 - (C) STRANDEDNESS: both
 - (D) TOPOLOGY: linear

(ii) MOLECULE TYPE: cDNA

(iii) HYPOTHETICAL: NO

(iv) ANTI-SENSE: NO

(xi) SEQUENCE DESCRIPTION: SEQ ID NO:36:

TATCACCGCA AGGGATAAAT ATCTAACACC GTGCGTGTTG ACTATTTTAC CTCTGGCGGT 60
GATA 64

(2) INFORMATION FOR SEQ ID NO:37:

- (i) SEQUENCE CHARACTERISTICS:
 - (A) LENGTH: 70 base pairs
 - (B) TYPE: nucleic acid
 - (C) STRANDEDNESS: both
 - (D) TOPOLOGY: linear

(ii) MOLECULE TYPE: cDNA

(iii) HYPOTHETICAL: NO

(iv) ANTI-SENSE: NO

(xi) SEQUENCE DESCRIPTION: SEQ ID NO:37:

CTACAAGGGA CTTTCCGCTG GGGACTTTC AGGGAGGCGT GGCCTGGGCG GACTGGGGA 60
GTGGCGTCCC 70

(2) INFORMATION FOR SEQ ID NO:38:

- (i) SEQUENCE CHARACTERISTICS:
 - (A) LENGTH: 37 base pairs
 - (B) TYPE: nucleic acid
 - (C) STRANDEDNESS: both
 - (D) TOPOLOGY: linear

(ii) MOLECULE TYPE: cDNA

(iii) HYPOTHETICAL: NO

(iv) ANTI-SENSE: NO

(xi) SEQUENCE DESCRIPTION: SEQ ID NO:38:

CTACAAGGGA CTTTCCGCTG GGGACTTTC AGGGAGG 37

(2) INFORMATION FOR SEQ ID NO:39:

- (i) SEQUENCE CHARACTERISTICS:
 - (A) LENGTH: 22 base pairs
 - (B) TYPE: nucleic acid
 - (C) STRANDEDNESS: both
 - (D) TOPOLOGY: linear

(ii) MOLECULE TYPE: cDNA

(iii) HYPOTHETICAL: NO

(iv) ANTI-SENSE: NO

(xi) SEQUENCE DESCRIPTION: SEQ ID NO:39:

CGGGACTGGG GAGTGGCGTC CC

22

(2) INFORMATION FOR SEQ ID NO:40:

(i) SEQUENCE CHARACTERISTICS:

- (A) LENGTH: 103 base pairs
- (B) TYPE: nucleic acid
- (C) STRANDEDNESS: both
- (D) TOPOLOGY: linear

(ii) MOLECULE TYPE: cDNA

(iii) HYPOTHETICAL: NO

(iv) ANTI-SENSE: NO

(xi) SEQUENCE DESCRIPTION: SEQ ID NO:40:

CTACAAGGGA CTTTCCGCTG GGGACTTTC AGGGAGGTAT CACCGCCAGT GGTATTTATG

60

TCAACACCGC CAGAGATAAT TTATCACCGC AGATGGTTCT GCA

103

(2) INFORMATION FOR SEQ ID NO:41:

(i) SEQUENCE CHARACTERISTICS:

- (A) LENGTH: 62 base pairs
- (B) TYPE: nucleic acid
- (C) STRANDEDNESS: both
- (D) TOPOLOGY: linear

(ii) MÅ

(iii) HYPOTHETICAL: NO

(iv) ANTI-SENSE: NO

(xi) SEQUENCE DESCRIPTION: SEQ ID NO:41:

GAACCATCTG CCGTGATAAA TTATCTCTGG CCGTGTGAC ATAAATACCA CTGGCGGTGA

60

TA

62

(2) INFORMATION FOR SEQ ID NO:42:

(i) SEQUENCE CHARACTERISTICS:

- (A) LENGTH: 71 base pairs
- (B) TYPE: nucleic acid
- (C) STRANDEDNESS: both
- (D) TOPOLOGY: linear

(ii) MOLECULE TYPE: cDNA

(iii) HYPOTHETICAL: NO

(iv) ANTI-SENSE: NO

(xi) SEQUENCE DESCRIPTION: SEQ ID NO:42:

GATCCAACCA TCTGCGGTGA TAAATTATCT CTGGCGGTGT TGACATAAAT ACCACTGGCG 60

GTGATACTGC A 71

(2) INFORMATION FOR SEQ ID NO:43:

- (i) SEQUENCE CHARACTERISTICS:
(A) LENGTH: 63 base pairs
(B) TYPE: nucleic acid
(C) STRANDEDNESS: both
(D) TOPOLOGY: linear

(ii) MOLECULE TYPE: cDNA

(iii) HYPOTHETICAL: NO

(iv) ANTI-SENSE: NO

(xi) SEQUENCE DESCRIPTION: SEQ ID NO:43:

GTATCACCGC CAGTGGTATT TATGTCAACA CCGCCAGAGA TAATTTATCA CCGCAGATGG 60

TTG 63

(2) INFORMATION FOR SEQ ID NO:44:

- (i) SEQUENCE CHARACTERISTICS:
(A) LENGTH: 21 base pairs
(B) TYPE: nucleic acid
(C) STRANDEDNESS: both
(D) TOPOLOGY: linear

(ii) MOLECULE TYPE: cDNA

(iii) HYPOTHETICAL: NO

(iv) ANTI-SENSE: NO

(xi) SEQUENCE DESCRIPTION: SEQ ID NO:44:

GATCCGGGGG GATACCCCC G 21

(2) INFORMATION FOR SEQ ID NO:45:

- (i) SEQUENCE CHARACTERISTICS:

79

- (A) LENGTH: 91 base pairs
- (B) TYPE: nucleic acid
- (C) STRANDEDNESS: both
- (D) TOPOLOGY: linear

(ii) MOLECULE TYPE: cDNA

(iii) HYPOTHETICAL: NO

(iv) ANTI-SENSE: NO

(xi) SEQUENCE DESCRIPTION: SEQ ID NO:45:

CGGGACTGGG GAGTGGCGTC CCTATCACCG CAAGGGATAA ATATCTAACA CCGTGC GTGT 60

TGACTATTTT ACCTCTGGCG GTGATAGCAT G 91

(2) INFORMATION FOR SEQ ID NO:46:

- (i) SEQUENCE CHARACTERISTICS:
 - (A) LENGTH: 53 base pairs
 - (B) TYPE: nucleic acid
 - (C) STRANDEDNESS: both
 - (D) TOPOLOGY: linear

(ii) MOLECULE TYPE: cDNA

(iii) HYPOTHETICAL: NO

(iv) ANTI-SENSE: NO

(xi) SEQUENCE DESCRIPTION: SEQ ID NO:46:

CTAAGGGCGT AACCGAAATC GGTGAACCG AAACCGGTTA GTATAAAGC AGA 53

(2) INFORMATION FOR SEQ ID NO:47:

- (i) SEQUENCE CHARACTERISTICS:
 - (A) LENGTH: 54 base pairs
 - (B) TYPE: nucleic acid
 - (C) STRANDEDNESS: both
 - (D) TOPOLOGY: linear

(ii) MOLECULE TYPE: cDNA

(iii) HYPOTHETICAL: NO

(iv) ANTI-SENSE: NO

(xi) SEQUENCE DESCRIPTION: SEQ ID NO:47:

AAAAGGGAGT AACCGAAAAC GGTCGGGACC GAAAACGGTG TATATAAAG ATGT 54

(2) INFORMATION FOR SEQ ID NO:48:

- (i) SEQUENCE CHARACTERISTICS:
 - (A) LENGTH: 54 base pairs
 - (B) TYPE: nucleic acid
 - (C) STRANDEDNESS: both
 - (D) TOPOLOGY: linear

(ii) MOLECULE TYPE: cDNA

(iii) HYPOTHETICAL: NO

(iv) ANTI-SENSE: NO

(xi) SEQUENCE DESCRIPTION: SEQ ID NO:48:

AGTAGGGTGT AACCGAAAGC GGTTCACCG AAAACGGTGC ATATATAAAG CAAA

54

(2) INFORMATION FOR SEQ ID NO:49:

- (i) SEQUENCE CHARACTERISTICS:
 - (A) LENGTH: 24 base pairs
 - (B) TYPE: nucleic acid
 - (C) STRANDEDNESS: both
 - (D) TOPOLOGY: linear

(ii) MOLECULE TYPE: cDNA

(iii) HYPOTHETICAL: NO

(iv) ANTI-SENSE: NO

(xi) SEQUENCE DESCRIPTION: SEQ ID NO:49:

GCTTCAACCG AATTCGGTTG CATG

24

(2) INFORMATION FOR SEQ ID NO:50:

- (i) SEQUENCE CHARACTERISTICS:
 - (A) LENGTH: 24 base pairs
 - (B) TYPE: nucleic acid
 - (C) STRANDEDNESS: both
 - (D) TOPOLOGY: linear

(ii) MOLECULE TYPE: cDNA

(iii) HYPOTHETICAL: NO

(iv) ANTI-SENSE: NO

(xi) SEQUENCE DESCRIPTION: SEQ ID NO:50:

TGTGCAACCG AATTCGGTTG CCTT

24

(2) INFORMATION FOR SEQ ID NO:51:

(i) SEQUENCE CHARACTERISTICS:
 (A) LENGTH: 24 base pairs
 (B) TYPE: nucleic acid
 (C) STRANDEDNESS: both
 (D) TOPOLOGY: linear

(ii) MOLECULE TYPE: cDNA

(iii) HYPOTHETICAL: NO

(iv) ANTI-SENSE: NO

(xi) SEQUENCE DESCRIPTION: SEQ ID NO:51:
TATGCAACCG AAATAGGTTG GGCA 24

(2) INFORMATION FOR SEQ ID NO:52:

(i) SEQUENCE CHARACTERISTICS:
 (A) LENGTH: 24 base pairs
 (B) TYPE: nucleic acid
 (C) STRANDEDNESS: both
 (D) TOPOLOGY: linear

(ii) MOLECULE TYPE: cDNA

(iii) HYPOTHETICAL: NO

(iv) ANTI-SENSE: NO

(xi) SEQUENCE DESCRIPTION: SEQ ID NO:52:
TGCCTAACCG TTTTCGGTTA CTTG 24

(2) INFORMATION FOR SEQ ID NO:53:

(i) SEQUENCE CHARACTERISTICS:
 (A) LENGTH: 24 base pairs
 (B) TYPE: nucleic acid
 (C) STRANDEDNESS: both
 (D) TOPOLOGY: linear

(ii) MOLECULE TYPE: cDNA

(iii) HYPOTHETICAL: NO

(iv) ANTI-SENSE: NO

(xi) SEQUENCE DESCRIPTION: SEQ ID NO:53:
GGACTAACCG TTTTAGGTCA TATT 24

82

(2) INFORMATION FOR SEQ ID NO:54:

- (i) SEQUENCE CHARACTERISTICS:
 - (A) LENGTH: 52 base pairs
 - (B) TYPE: nucleic acid
 - (C) STRANDEDNESS: both
 - (D) TOPOLOGY: linear

(ii) MOLECULE TYPE: cDNA

(iii) HYPOTHETICAL: NO

(iv) ANTI-SENSE: NO

(xi) SEQUENCE DESCRIPTION: SEQ ID NO:54:

GACGACTATC CAGCGACCAA GATCAGAGCC AGACACCGGA AACCCCTGCC AC

52

(2) INFORMATION FOR SEQ ID NO:55:

- (i) SEQUENCE CHARACTERISTICS:
 - (A) LENGTH: 53 base pairs
 - (B) TYPE: nucleic acid
 - (C) STRANDEDNESS: both
 - (D) TOPOLOGY: linear

(ii) MOLECULE TYPE: cDNA

(iii) HYPOTHETICAL: NO

(iv) ANTI-SENSE: NO

(xi) SEQUENCE DESCRIPTION: SEQ ID NO:55:

GACGACACGG TATCCGCTAC TCAGCTTGTT AACAGCTAC AGCACACCCC CTC

53

(2) INFORMATION FOR SEQ ID NO:56:

- (i) SEQUENCE CHARACTERISTICS:
 - (A) LENGTH: 60 base pairs
 - (B) TYPE: nucleic acid
 - (C) STRANDEDNESS: both
 - (D) TOPOLOGY: linear

(ii) MOLECULE TYPE: cDNA

(iii) HYPOTHETICAL: NO

(iv) ANTI-SENSE: NO

(xi) SEQUENCE DESCRIPTION: SEQ ID NO:56:

GACGACGACC TGCAGACACC ACAGACACCG CCCAGCCCCT TACAAAGCTG TTCTGTGCAG

60

(2) INFORMATION FOR SEQ ID NO:57:

- (i) SEQUENCE CHARACTERISTICS:
 - (A) LENGTH: 68 base pairs
 - (B) TYPE: nucleic acid
 - (C) STRANDEDNESS: both
 - (D) TOPOLOGY: linear

(ii) MOLECULE TYPE: cDNA

(iii) HYPOTHETICAL: NO

(iv) ANTI-SENSE: NO

(xi) SEQUENCE DESCRIPTION: SEQ ID NO:57:

CATACCAAAG CCGTCGCCTT GGGCACCGAA GAAACACAAC CACTAAGTTG TTGCACAGAG 60

ACTCAGTG 68

(2) INFORMATION FOR SEQ ID NO:58:

- (i) SEQUENCE CHARACTERISTICS:
 - (A) LENGTH: 77 base pairs
 - (B) TYPE: nucleic acid
 - (C) STRANDEDNESS: both
 - (D) TOPOLOGY: linear

(ii) MOLECULE TYPE: cDNA

(iii) HYPOTHETICAL: NO

(iv) ANTI-SENSE: NO

(xi) SEQUENCE DESCRIPTION: SEQ ID NO:58:

TAATGTAATT GATTGTAATG ACTCTATGTG CAGTACCAGT ACCGTATTCC AGCACCGTGT 60

CCGTGGGCAC CGCAAAG 77

(2) INFORMATION FOR SEQ ID NO:59:

- (i) SEQUENCE CHARACTERISTICS:
 - (A) LENGTH: 80 base pairs
 - (B) TYPE: nucleic acid
 - (C) STRANDEDNESS: both
 - (D) TOPOLOGY: linear

(ii) MOLECULE TYPE: cDNA

(iii) HYPOTHETICAL: NO

(iv) ANTI-SENSE: NO

(xi) SEQUENCE DESCRIPTION: SEQ ID NO:59:

ACAGACAACG ATAACCGACC ACCACAAGCA GCGGCCAAAC ACCCCGCCTT GGACAATAGA 60
 ACAGCACGTA CTGCAACTAA 80

(2) INFORMATION FOR SEQ ID NO:60:

- (i) SEQUENCE CHARACTERISTICS:
 - (A) LENGTH: 266 base pairs
 - (B) TYPE: nucleic acid
 - (C) STRANDEDNESS: both
 - (D) TOPOLOGY: linear

(ii) MOLECULE TYPE: cDNA

(iii) HYPOTHETICAL: NO

(iv) ANTI-SENSE: NO

(xi) SEQUENCE DESCRIPTION: SEQ ID NO:60:

CATATGCAAT ACAATGCATT ATACAAACTG GACACATATA TATATTTGTG AAGAAGCATC 60
 AGTAACTGTG GTAGAGGGTC AAGTTGACTA TTATGGTTTA TATTATGTTC ATGAAGGAAT 120
 ACGAACATAT TTTGTGCAGT TTAAAGATGA TGCAGAAAAA TATAGTAAAA ATAAAGTATG 180
 GGAAGTTCAT GCGGGTGGTC AGGTAATATT ATGTCCTACA TCTGTGTTTA GCAGCAACGA 240
 AGTATCCTCT CCTGAAATTA TTAGGC 266

(2) INFORMATION FOR SEQ ID NO:61:

- (i) SEQUENCE CHARACTERISTICS:
 - (A) LENGTH: 95 base pairs
 - (B) TYPE: nucleic acid
 - (C) STRANDEDNESS: both
 - (D) TOPOLOGY: linear

(ii) MOLECULE TYPE: cDNA

(iii) HYPOTHETICAL: NO

(iv) ANTI-SENSE: NO

(xi) SEQUENCE DESCRIPTION: SEQ ID NO:61:

AGGATGTATA AAAAAACATG GATATACAGT GGAAGTGCAG TTTGATGGAG ACATATGCTA 60
 TTAGGCAGCA CTTGGCCAAC CACCCCGCCG CGACC 95

(2) INFORMATION FOR SEQ ID NO:62:

- (i) SEQUENCE CHARACTERISTICS:
 - (A) LENGTH: 81 base pairs
 - (B) TYPE: nucleic acid
 - (C) STRANDEDNESS: both
 - (D) TOPOLOGY: linear

(ii) MOLECULE TYPE: cdna

(iii) HYPOTHETICAL: NO

(iv) ANTI-SENSE: NO

(xi) SEQUENCE DESCRIPTION: SEQ ID NO:62:

CATGTTTTTT TATACATCCA TATCACCGCC AGTGGTATTT ATGTCAACAC CGCCAGAGAT 60
 AATTATCAC CGCAGATGGT T 81

(2) INFORMATION FOR SEQ ID NO:63:

- (i) SEQUENCE CHARACTERISTICS:
 - (A) LENGTH: 322 amino acids
 - (B) TYPE: amino acid
 - (D) TOPOLOGY: linear

(ii) MOLECULE TYPE: peptide

(iii) HYPOTHETICAL: NO

(iv) ANTI-SENSE: NO

(v) FRAGMENT TYPE: internal

(xi) SEQUENCE DESCRIPTION: SEQ ID NO:63:

Met Ala Asp Asp Asp Pro Tyr Gly Thr Gly Gln Met Phe His Leu Asn
 1 5 10 15
 Thr Ala Leu Thr His Ser Ile Phe Asn Ala Glu Leu Tyr Ser Pro Glu
 20 25 30
 Ile Pro Leu Ser Thr Asp Gly Pro Tyr Leu Gln Ile Leu Glu Gln Pro
 35 40 45
 Lys Gln Arg Gly Phe Arg Phe Arg Tyr Val Cys Glu Gly Pro Ser His
 50 55 60
 Gly Gly Leu Pro Gly Ala Ser Ser Glu Lys Asn Lys Lys Ser Tyr Pro
 65 70 75 80
 Gln Val Lys Ile Cys Asn Tyr Val Gly Pro Ala Lys Val Ile Val Gln
 85 90 95
 Leu Val Thr Asn Gly Lys Asn Ile His Leu His Ala His Ser Leu Val
 100 105 110

86

Gly Lys His Cys Glu Asp Gly Val Cys Thr Val Thr Ala Gly Pro Lys
 115 120 125
 Asp Met Val Val Gly Phe Ala Asn Leu Gly Ile Leu His Val Thr Lys
 130 135 140
 Lys Lys Val Phe Glu Thr Leu Glu Ala Arg Met Thr Glu Ala Cys Ile
 145 150 155 160
 Arg Gly Tyr Asn Pro Gly Leu Leu Val His Ser Asp Leu Ala Tyr Leu
 165 170 175
 Gln Ala Glu Gly Gly Gly Asp Arg Gln Leu Thr Asp Arg Glu Lys Glu
 180 185 190
 Ile Ile Arg Gln Ala Ala Val Gln Gln Thr Lys Glu Met Asp Leu Ser
 195 200 205
 Val Val Arg Leu Met Phe Thr Ala Phe Leu Pro Asp Ser Thr Gly Ser
 210 215 220
 Phe Thr Arg Arg Leu Glu Pro Val Val Ser Asp Ala Ile Tyr Asp Ser
 225 230 235 240
 Lys Ala Pro Asn Ala Ser Asn Leu Lys Ile Val Arg Met Asp Arg Thr
 245 250 255
 Ala Gly Cys Val Thr Gly Gly Glu Glu Ile Tyr Leu Leu Cys Asp Lys
 260 265 270
 Val Gln Lys Asp Asp Ile Gln Ile Arg Phe Tyr Glu Glu Glu Glu Asn
 275 280 285
 Gly Gly Val Trp Glu Gly Phe Gly Asp Phe Ser Pro Thr Asp Val His
 290 295 300
 Arg Gln Phe Ala Ile Val Phe Lys Thr Pro Lys Tyr Lys Asp Val Asn
 305 310 315 320
 Ile Thr

(2) INFORMATION FOR SEQ ID NO:64:

- (i) SEQUENCE CHARACTERISTICS:
 - (A) LENGTH: 325 amino acids
 - (B) TYPE: amino acid
 - (D) TOPOLOGY: linear
- (ii) MOLECULE TYPE: peptide
- (iii) HYPOTHETICAL: NO
- (iv) ANTI-SENSE: NO
- (v) FRAGMENT TYPE: internal

(xi) SEQUENCE DESCRIPTION: SEQ ID NO:64:

Met Ala Glu Asp Asp Pro Tyr Leu Gly Arg Pro Glu Gln Met Phe His
 1 5 10 15
 Leu Asp Pro Ser Leu Thr His Thr Ile Phe Asn Pro Glu Val Phe Gln
 20 25 30
 Pro Gln Met Ala Leu Pro Thr Ala Asp Gly Pro Tyr Leu Gln Ile Leu
 35 40 45
 Glu Gln Pro Lys Gln Arg Gly Phe Arg Phe Arg Tyr Val Cys Glu Gly
 50 55 60
 Pro Ser His Gly Gly Leu Pro Gly Ala Ser Ser Glu Lys Asn Lys Lys
 65 70 75 80
 Ser Tyr Pro Gln Val Lys Ile Cys Asn Tyr Val Gly Pro Ala Lys Val
 85 90 95
 Ile Val Gln Leu Val Thr Asn Gly Lys Asn Ile His Leu His Ala His
 100 105 110
 Ser Leu Val Gly Lys His Cys Glu Asp Gly Ile Cys Thr Val Thr Ala
 115 120 125
 Gly Pro Glu Asp Cys Val His Gly Phe Ala Asn Leu Gly Ile Leu His
 130 135 140
 Val Thr Lys Lys Lys Val Phe Glu Thr Leu Glu Ala Arg Met Thr Glu
 145 150 155 160
 Ala Cys Ile Arg Gly Tyr Asn Pro Gly Leu Leu Val His Pro Asp Leu
 165 170 175
 Ala Tyr Leu Gln Ala Glu Gly Gly Gly Asp Arg Gln Leu Gly Asp Arg
 180 185 190
 Glu Lys Glu Leu Ile Arg Gln Ala Ala Leu Gln Gln Thr Lys Glu Met
 195 200 205
 Asp Leu Ser Val Val Arg Leu Met Phe Thr Ala Phe Leu Pro Asp Ser
 210 215 220
 Thr Gly Ser Phe Thr Arg Arg Leu Glu Pro Val Val Ser Asp Ala Ile
 225 230 235 240
 Tyr Asp Ser Lys Ala Pro Asn Ala Ser Asn Leu Lys Ile Val Arg Met
 245 250 255
 Asp Arg Thr Ala Gly Cys Val Thr Gly Gly Glu Glu Ile Tyr Leu Leu
 260 265 270
 Cys Asp Lys Val Gln Lys Asp Asp Ile Gln Ile Arg Phe Tyr Glu Glu
 275 280 285

Glu Glu Asn Gly Gly Val Trp Glu Gly Phe Gly Asp Phe Ser Pro Thr
 290 295 300

Asp Val His Arg Gln Phe Ala Ile Val Phe Lys Thr Pro Lys Tyr Lys
 305 310 315 320

Asp Ile Asn Ile Thr
 325

(2) INFORMATION FOR SEQ ID NO:65:

(i) SEQUENCE CHARACTERISTICS:
 (A) LENGTH: 268 amino acids
 (B) TYPE: amino acid
 (D) TOPOLOGY: linear

(ii) MOLECULE TYPE: peptide

(iii) HYPOTHETICAL: NO

(iv) ANTI-SENSE: NO

(v) FRAGMENT TYPE: internal

(xi) SEQUENCE DESCRIPTION: SEQ ID NO:65:

Met Glu Pro Ala Asp Leu Leu Pro Leu Tyr Leu Gln Pro Glu Trp Gly
 1 5 10 15

Glu Gln Glu Pro Gly Gly Ala Thr Pro Phe Val Glu Ile Leu Glu Gln
 20 25 30

Pro Lys Gln Arg Gly Met Arg Phe Arg Tyr Lys Cys Glu Gly Arg Ser
 35 40 45

Ala Gly Ser Ile Pro Gly Glu His Ser Thr Asp Ser Ala Arg Thr His
 50 55 60

Pro Thr Ile Arg Val Asn His Tyr Arg Gly Pro Gly Arg Val Arg Val
 65 70 75 80

Ser Leu Val Thr Lys Asp Pro Pro His Gly Pro His Pro His Glu Leu
 85 90 95

Val Gly Arg His Cys Gln His Gly Tyr Tyr Glu Ala Glu Leu Ser Pro
 100 105 110

Asp Arg Ser Ile His Ser Phe Gln Asn Leu Gly Ile Gln Cys Val Lys
 115 120 125

Lys Arg Glu Leu Glu Ala Ala Val Ala Glu Arg Ile Arg Thr Asn Asn
 130 135 140

Asn Pro Phe Asn Val Pro Met Glu Glu Arg Gly Ala Glu Tyr Asp Leu
 145 150 155 160

Ser Ala Val Arg Leu Cys Phe Gln Val Trp Val Asn Gly Pro Gly Gly
 165 170 175

Leu Cys Pro Leu Pro Pro Val Leu Ser Gln Pro Ile Tyr Asp Asn Arg
 180 185 190

Ala Pro Ser Thr Ala Glu Leu Arg Ile Leu Pro Gly Asp Arg Asn Ser
 195 200 205

Gly Ser Cys Gln Gly Gly Asp Glu Ile Phe Leu Leu Cys Asp Lys Val
 210 215 220

Gln Lys Glu Asp Ile Glu Val Arg Phe Trp Ala Glu Gly Trp Glu Ala
 225 230 235 240

Lys Gly Ser Phe Ala Ala Ala Asp Val His Arg Gln Val Ala Ile Val
 245 250 255

Phe Arg Thr Pro Pro Phe Arg Glu Arg Ser Leu Arg
 260 265

(2) INFORMATION FOR SEQ ID NO:66:

- (i) SEQUENCE CHARACTERISTICS:
 (A) LENGTH: 263 amino acids
 (B) TYPE: amino acid
 (D) TOPOLOGY: linear
- (ii) MOLECULE TYPE: peptide
- (iii) HYPOTHETICAL: NO
- (iv) ANTI-SENSE: NO
- (v) FRAGMENT TYPE: internal
- (xi) SEQUENCE DESCRIPTION: SEQ ID NO:66:
- Met Asp Asp Leu Phe Pro Leu Ile Phe Pro Ser Glu Pro Ala Gln Ala
 1 5 10 15
- Ser Gly Pro Tyr Val Glu Ile Ile Glu Gln Pro Lys Gln Arg Gly Met
 20 25 30
- Arg Phe Arg Tyr Lys Cys Glu Gly Arg Ser Ala Gly Ser Ile Pro Gly
 35 40 45
- Glu Arg Ser Thr Asp Thr Thr Lys Thr His Pro Thr Ile Lys Ile Asn
 50 55 60
- Gly Tyr Thr Gly Pro Gly Thr Val Arg Ile Ser Leu Val Thr Lys Asp
 65 70 75 80

Pro Pro His Arg Pro His Pro His Glu Leu Val Gly Lys Asp Cys Arg
 85 90 95

Asp Gly Tyr Tyr Glu Ala Asp Leu Cys Pro Asp Arg Ser Ile His Ser
 100 105 110

Phe Gln Asn Leu Gly Ile Gln Cys Val Lys Lys Arg Asp Leu Glu Gln
 115 120 125

Ala Ile Ser Gln Arg Ile Gln Thr Asn Asn Asn Pro Phe His Val Pro
 130 135 140

Ile Glu Glu Gln Arg Gly Asp Tyr Asp Leu Asn Ala Val Arg Leu Cys
 145 150 155 160

Phe Gln Val Thr Val Arg Asp Pro Ala Gly Arg Pro Leu Leu Leu Thr
 165 170 175

Pro Val Leu Ser His Pro Ile Phe Asp Asn Arg Ala Pro Asn Thr Ala
 180 185 190

Glu Leu Lys Ile Cys Arg Val Asn Arg Asn Ser Gly Ser Cys Leu Gly
 195 200 205

Gly Asp Glu Ile Phe Leu Leu Cys Asp Lys Val Gln Lys Glu Asp Ile
 210 215 220

Glu Val Tyr Phe Thr Gly Pro Gly Trp Glu Ala Arg Gly Ser Phe Ser
 225 230 235 240

Gln Ala Asp Val His Arg Gln Val Ala Ile Val Phe Arg Thr Pro Pro
 245 250 255

Tyr Ala Asp Pro Ser Leu Gln
 260

(2) INFORMATION FOR SEQ ID NO:67:

- (i) SEQUENCE CHARACTERISTICS:
 - (A) LENGTH: 263 amino acids
 - (B) TYPE: amino acid
 - (D) TOPOLOGY: linear
- (ii) MOLECULE TYPE: peptide
- (iii) HYPOTHETICAL: NO
- (iv) ANTI-SENSE: NO
- (v) FRAGMENT TYPE: internal
- (xi) SEQUENCE DESCRIPTION: SEQ ID NO:67:

Met Asp Glu Leu Phe Pro Leu Ile Phe Pro Ala Glu Pro Ala Gln Ala
 1 5 10 15

Ser Gly Pro Tyr Val Glu Ile Ile Glu Gln Pro Lys Gln Arg Gly Met
 20 25 30

Arg Phe Arg Tyr Lys Cys Glu Gly Arg Ser Ala Gly Ser Ile Pro Gly
 35 40 45

Glu Arg Ser Thr Asp Thr Thr Lys Thr His Pro Thr Ile Lys Ile Asn
 50 55 60

Gly Tyr Thr Gly Pro Gly Thr Val Arg Ile Ser Leu Val Thr Lys Asp
 65 70 75 80

Pro Pro His Arg Pro His Pro His Glu Leu Val Gly Lys Asp Cys Arg
 85 90 95

Asp Gly Phe Tyr Glu Ala Glu Leu Cys Pro Asp Arg Cys Ile His Ser
 100 105 110

Phe Gln Asn Leu Gly Ile Gln Cys Val Lys Lys Arg Asp Leu Glu Gln
 115 120 125

Ala Ile Ser Gln Arg Ile Gln Thr Asn Asn Asn Pro Phe Gln Val Pro
 130 135 140

Ile Glu Glu Gln Arg Gly Asp Tyr Asp Leu Asn Ala Val Arg Leu Cys
 145 150 155 160

Phe Gln Val Thr Val Arg Asp Pro Ser Gly Arg Pro Leu Arg Leu Pro
 165 170 175

Pro Val Leu Pro His Pro Ile Phe Asp Asn Arg Ala Pro Asn Thr Ala
 180 185 190

Glu Leu Lys Ile Cys Arg Val Asn Arg Asn Ser Gly Ser Cys Leu Gly
 195 200 205

Gly Asp Glu Ile Phe Leu Leu Cys Asp Lys Val Gln Lys Glu Asp Ile
 210 215 220

Glu Val Tyr Phe Thr Gly Pro Gly Trp Glu Ala Arg Gly Ser Phe Ser
 225 230 235 240

Gln Ala Asp Val His Arg Gln Val Ala Ile Val Phe Arg Thr Pro Pro
 245 250 255

Tyr Ala Asp Pro Ser Leu Gln
 260

(2) INFORMATION FOR SEQ ID NO:68:

- (i) SEQUENCE CHARACTERISTICS:
 - (A) LENGTH: 299 amino acids
 - (B) TYPE: amino acid
 - (D) TOPOLOGY: linear

(ii) MOLECULE TYPE: peptide

(iii) HYPOTHETICAL: NO

(iv) ANTI-SENSE: NO

(v) FRAGMENT TYPE: internal

(xi) SEQUENCE DESCRIPTION: SEQ ID NO:68:

```

Met Phe Pro Asn Gln Asn Asn Gly Ala Ala Pro Gly Gln Gly Pro Ala
1           5           10           15

Val Asp Gly Gln Gln Ser Leu Asn Tyr Asn Gly Leu Pro Ala Gln Gln
          20           25           30

Gln Gln Gln Leu Ala Gln Ser Thr Lys Asn Val Arg Lys Lys Pro Tyr
          35           40           45

Val Lys Ile Thr Glu Gln Pro Ala Gly Lys Ala Leu Arg Phe Arg Tyr
          50           55           60

Glu Cys Glu Gly Arg Ser Ala Gly Ser Ile Pro Gly Val Asn Ser Thr
65           70           75           80

Pro Glu Asn Lys Thr Tyr Pro Thr Ile Glu Ile Val Gly Tyr Lys Gly
          85           90           95

Arg Ala Val Val Val Val Ser Cys Val Thr Lys Asp Thr Pro Tyr Arg
          100          105          110

Pro His Pro His Asn Leu Val Gly Lys Glu Gly Cys Lys Lys Gly Val
          115          120          125

Cys Thr Leu Glu Ile Asn Ser Glu Thr Met Arg Ala Val Phe Ser Asn
130          135          140

Leu Gly Ile Gln Cys Val Lys Lys Lys Asp Ile Glu Ala Ala Leu Lys
145          150          155          160

Ala Arg Glu Glu Ile Arg Val Asp Pro Phe Lys Thr Gly Phe Ser His
          165          170          175

Arg Phe Gln Pro Ser Ser Ile Asp Leu Asn Ser Val Arg Leu Cys Phe
          180          185          190

Gln Val Phe Met Glu Ser Glu Gln Lys Gly Arg Phe Thr Ser Pro Leu
          195          200          205

Pro Pro Val Val Ser Glu Pro Ile Phe Asp Lys Lys Ala Met Ser Asp
210          215          220

Leu Val Ile Cys Arg Leu Cys Ser Cys Ser Ala Thr Val Phe Gly Asn
225          230          235          240

Thr Gln Ile Ile Leu Leu Cys Glu Lys Val Ala Lys Glu Asp Ile Ser
          245          250          255

```

Val Arg Phe Phe Glu Glu Lys Asn Gly Gln Ser Val Trp Glu Ala Phe
 260 265 270

Gly Asp Phe Gln His Thr Asp Val His Lys Gln Thr Ala Ile Thr Phe
 275 280 285

Lys Thr Pro Arg Tyr His Thr Leu Asp Ile Thr
 290 295

(2) INFORMATION FOR SEQ ID NO:69:

(i) SEQUENCE CHARACTERISTICS:

- (A) LENGTH: 261 amino acids
- (B) TYPE: amino acid
- (D) TOPOLOGY: linear

(ii) MOLECULE TYPE: peptide

(iii) HYPOTHETICAL: NO

(iv) ANTI-SENSE: NO

(v) FRAGMENT TYPE: internal

(xi) SEQUENCE DESCRIPTION: SEQ ID NO:69:

Met Asp Phe Leu Thr Asn Leu Arg Phe Thr Glu Gly Ile Ser Glu Pro
 1 5 10 15

Tyr Ile Glu Ile Phe Glu Gln Pro Arg Gln Arg Gly Thr Arg Phe Arg
 20 25 30

Tyr Lys Cys Glu Gly Arg Ser Ala Gly Ser Ile Pro Gly Glu His Ser
 35 40 45

Thr Asp Asn Asn Lys Thr Phe Pro Ser Ile Gln Ile Leu Asn Tyr Phe
 50 55 60

Gly Lys Val Lys Ile Arg Thr Thr Leu Val Thr Lys Asn Glu Pro Tyr
 65 70 75 80

Lys Pro His Pro His Asp Leu Val Gly Lys Gly Cys Arg Asp Gly Tyr
 85 90 95

Tyr Glu Ala Glu Phe Gly Pro Glu Arg Gln Val Leu Ser Phe Gln Asn
 100 105 110

Leu Gly Ile Gln Cys Val Lys Lys Lys Asp Leu Lys Glu Ser Ile Ser
 115 120 125

Leu Arg Ile Ser Lys Lys Asn Pro Phe Asn Val Pro Glu Glu Gln Leu
 130 135 140

His Asn Ile Asp Glu Tyr Asp Leu Asn Val Val Arg Leu Cys Phe Gln
 145 150 155 160

Ala Phe Leu Pro Asp Glu His Gly Asn Tyr Thr Leu Ala Leu Pro Pro
 165 170 175

Leu Ile Ser Asn Pro Ile Tyr Asp Asn Arg Ala Pro Asn Thr Ala Glu
 180 185 190

Leu Arg Ile Cys Arg Val Asn Lys Asn Cys Gly Ser Val Lys Gly Gly
 195 200 205

Asp Glu Ile Phe Leu Leu Cys Asp Lys Val Gln Lys Asp Asp Ile Glu
 210 215 220

Val Arg Phe Val Leu Gly Asn Trp Glu Ala Lys Gly Ser Phe Ser Gln
 225 230 235 240

Ala Asp Val His Arg Gln Val Ala Ile Val Phe Arg Thr Pro Pro Phe
 245 250 255

Leu Gly Asp Ile Thr
 260

(2) INFORMATION FOR SEQ ID NO:70:

- (i) SEQUENCE CHARACTERISTICS:
 - (A) LENGTH: 262 amino acids
 - (B) TYPE: amino acid
 - (D) TOPOLOGY: linear

(ii) MOLECULE TYPE: peptide

(iii) HYPOTHETICAL: NO

(iv) ANTI-SENSE: NO

(v) FRAGMENT TYPE: internal

(xi) SEQUENCE DESCRIPTION: SEQ ID NO:70:

Met Asp Phe Leu Thr Asn Leu Arg Phe Thr Glu Gly Ile Ser Glu Pro
 1 5 10 15

Tyr Ile Glu Ile Phe Glu Gln Pro Arg Gln Arg Gly Met Arg Phe Arg
 20 25 30

Tyr Lys Cys Glu Gly Arg Ser Ala Gly Ser Ile Pro Gly Glu His Ser
 35 40 45

Thr Asp Asn Asn Lys Thr Phe Pro Ser Ile Gln Ile Leu Asn Tyr Phe
 50 55 60

Gly Lys Val Lys Ile Arg Thr Thr Leu Val Thr Lys Asn Glu Pro Tyr
 65 70 75 80

95

Lys	Pro	His	Pro	His	Asp	Leu	Val	Gly	Lys	Gly	Cys	Arg	Asp	Gly	Tyr				
				85					90					95					
Tyr	Glu	Ala	Glu	Phe	Gly	Pro	Glu	Arg	Gln	Val	Leu	Ser	Phe	Gln	Asn				
			100					105						110					
Leu	Gly	Ile	Gln	Cys	Val	Lys	Lys	Lys	Asp	Leu	Lys	Glu	Ser	Ile	Ser				
		115					120						125						
Leu	Arg	Ile	Ser	Lys	Lys	Ile	Asn	Pro	Phe	Asn	Val	Pro	Glu	Glu	Gln				
	130					135					140								
Leu	His	Asn	Ile	Asp	Glu	Tyr	Asp	Leu	Asn	Val	Val	Arg	Leu	Cys	Phe				
145				150						155					160				
Gln	Ala	Phe	Leu	Pro	Asp	Glu	His	Gly	Asn	Tyr	Thr	Leu	Ala	Leu	Pro				
				165					170						175				
Pro	Leu	Ile	Ser	Asn	Pro	Ile	Tyr	Asp	Asn	Arg	Ala	Pro	Asn	Thr	Ala				
			180					185						190					
Glu	Leu	Arg	Ile	Cys	Arg	Val	Asn	Lys	Asn	Cys	Gly	Ser	Val	Lys	Gly				
		195					200						205						
Gly	Asp	Glu	Ile	Phe	Leu	Leu	Cys	Asp	Lys	Val	Gln	Lys	Asp	Asp	Ile				
	210					215					220								
Glu	Val	Arg	Phe	Val	Leu	Gly	Asn	Trp	Glu	Ala	Lys	Gly	Ser	Phe	Ser				
225					230					235					240				
Gln	Ala	Asp	Val	His	Arg	Gln	Val	Ala	Ile	Val	Phe	Arg	Thr	Pro	Pro				
				245					250						255				
Phe	Leu	Gly	Asp	Ile	Thr														
			260																

(2) INFORMATION FOR SEQ ID NO:71:

- (i) SEQUENCE CHARACTERISTICS:
 - (A) LENGTH: 314 amino acids
 - (B) TYPE: amino acid
 - (D) TOPOLOGY: linear

- (ii) MOLECULE TYPE: peptide

- (iii) HYPOTHETICAL: NO

- (iv) ANTI-SENSE: NO

- (v) FRAGMENT TYPE: internal

- (xi) SEQUENCE DESCRIPTION: SEQ ID NO:71:

Met	Ser	Asn	Lys	Lys	Gln	Ser	Asn	Arg	Leu	Thr	Glu	Gln	His	Lys	Leu				
1			5					10						15					

96

Ser Gln Gly Val Ile Gly Ile Phe Gly Asp Tyr Ala Lys Ala His Asp
 20 25 30

Leu Ala Val Gly Glu Val Ser Lys Leu Val Lys Lys Ala Leu Ser Asn
 35 40 45

Glu Tyr Pro Gln Leu Ser Phe Arg Tyr Arg Asp Ser Ile Lys Lys Thr
 50 55 60

Glu Ile Asn Glu Ala Leu Lys Lys Ile Asp Pro Asp Leu Gly Gly Thr
 65 70 75 80

Leu Phe Val Ser Asn Ser Ser Ile Lys Pro Asp Gly Gly Ile Val Glu
 85 90 95

Val Lys Asp Asp Tyr Gly Glu Trp Arg Val Val Leu Val Ala Glu Ala
 100 105 110

Lys His Gln Gly Lys Asp Ile Ile Asn Ile Arg Asn Gly Leu Leu Val
 115 120 125

Gly Lys Arg Gly Asp Gln Asp Leu Met Ala Ala Gly Asn Ala Ile Glu
 130 135 140

Arg Ser His Asn Ile Ser Glu Ile Ala Asn Phe Met Leu Ser Glu Ser
 145 150 155 160

His Phe Pro Tyr Val Leu Phe Leu Glu Gly Ser Asn Phe Leu Thr Glu
 165 170 175

Asn Ile Ser Ile Thr Arg Pro Asp Gly Arg Val Val Asn Leu Glu Tyr
 180 185 190

Asn Ser Gly Ser Glu Ser His Phe Pro Tyr Val Leu Phe Leu Glu Gly
 195 200 205

Ser Asn Phe Leu Thr Glu Asn Ile Ser Ile Thr Arg Pro Asp Gly Arg
 210 215 220

Val Val Asn Leu Glu Tyr Asn Ser Gly Ile Leu Asn Arg Leu Asp Arg
 225 230 235 240

Leu Thr Ala Ala Asn Tyr Gly Met Pro Ile Asn Ser Asn Leu Cys Ile
 245 250 255

Asn Lys Phe Val Asn His Lys Asp Lys Ser Ile Met Leu Gln Ala Ala
 260 265 270

Ser Ile Tyr Thr Gln Gly Asp Gly Arg Glu Trp Asp Ser Lys Ile Met
 275 280 285

Phe Glu Ile Met Phe Asp Ile Ser Thr Thr Ser Leu Arg Val Leu Gly
 290 295 300

Arg Asp Leu Phe Glu Gln Leu Thr Ser Lys
 305 310

(2) INFORMATION FOR SEQ ID NO:72:

- (i) SEQUENCE CHARACTERISTICS:
 - (A) LENGTH: 17 amino acids
 - (B) TYPE: amino acid
 - (D) TOPOLOGY: linear

(ii) MOLECULE TYPE: peptide

(iii) HYPOTHETICAL: NO

(iv) ANTI-SENSE: NO

(v) FRAGMENT TYPE: internal

(xi) SEQUENCE DESCRIPTION: SEQ ID NO:72:

Cys Asp Thr Asp Asp Arg His Arg Ile Glu Glu Lys Arg Lys Arg Lys
 1 5 10 15

Thr

(2) INFORMATION FOR SEQ ID NO:73:

- (i) SEQUENCE CHARACTERISTICS:
 - (A) LENGTH: 168 amino acids
 - (B) TYPE: amino acid
 - (D) TOPOLOGY: linear

(ii) MOLECULE TYPE: peptide

(iii) HYPOTHETICAL: NO

(iv) ANTI-SENSE: NO

(v) FRAGMENT TYPE: internal

(xi) SEQUENCE DESCRIPTION: SEQ ID NO:73:

Gly Asp Pro Gly Lys Lys Lys Gln His Ile Cys His Ile Gln Gly Cys
 1 5 10 15

Gly Lys Val Tyr Gly Lys Thr Ser His Leu Arg Ala His Leu Arg Trp
 20 25 30

His Thr Gly Glu Arg Pro Phe Met Cys Thr Trp Ser Tyr Cys Gly Lys
 35 40 45

Arg Phe Thr Arg Ser Asp Glu Leu Gln Arg His Lys Arg Thr His Thr
 50 55 60

Gly Glu Lys Lys Phe Ala Cys Pro Glu Cys Pro Lys Arg Phe Met Arg
 65 70 75 80

Ser Asp His Leu Ser Lys His Ile Lys Thr His Gln Asn Lys Lys Gly
 85 90 95

Gly Pro Gly Val Ala Leu Ser Val Gly Thr Leu Pro Leu Asp Ser Gly
 100 105 110

Ala Gly Ser Glu Gly Ser Gly Thr Ala Thr Pro Ser Ala Leu Ile Thr
 115 120 125

Thr Asn Met Val Ala Met Glu Ala Ile Cys Pro Glu Gly Ile Ala Arg
 130 135 140

Leu Ala Asn Ser Gly Ile Asn Val Met Gln Val Ala Asp Leu Gln Ser
 145 150 155 160

Ile Asn Ile Ser Gly Asn Gly Phe
 165

(2) INFORMATION FOR SEQ ID NO:74:

(i) SEQUENCE CHARACTERISTICS:

- (A) LENGTH: 181 amino acids
- (B) TYPE: amino acid
- (D) TOPOLOGY: linear

(ii) MOLECULE TYPE: peptide

(iii) HYPOTHETICAL: NO

(iv) ANTI-SENSE: NO

(v) FRAGMENT TYPE: internal

(xi) SEQUENCE DESCRIPTION: SEQ ID NO:74:

Ser Gly Ile Val Pro Gln Leu Gln Asn Ile Val Ser Thr Val Asn Leu
 1 5 10 15

Gly Cys Lys Leu Asp Leu Lys Thr Ile Ala Leu Arg Ala Arg Asn Ala
 20 25 30

Glu Tyr Asn Pro Lys Arg Phe Ala Ala Val Ile Met Arg Ile Arg Glu
 35 40 45

Pro Arg Thr Thr Ala Leu Ile Phe Ser Ser Gly Lys Met Val Cys Thr
 50 55 60

Gly Ala Lys Ser Glu Glu Gln Ser Arg Leu Ala Ala Arg Lys Tyr Ala
 65 70 75 80

Arg Val Val Gln Lys Leu Gly Phe Pro Ala Lys Phe Leu Asp Phe Lys
 85 90 95

Ile Gln Asn Met Val Gly Ser Cys Asp Val Lys Phe Pro Ile Arg Leu
 100 105 110

Glu Gly Leu Val Leu Thr His Gln Gln Phe Ser Ser Tyr Glu Pro Glu
 115 120 125

Leu Phe Pro Gly Leu Ile Tyr Arg Met Ile Lys Pro Arg Ile Val Leu
 130 135 140

Leu Ile Phe Val Ser Gly Lys Val Val Leu Thr Gly Ala Lys Val Arg
 145 150 155 160

Ala Glu Ile Tyr Glu Ala Phe Glu Asn Ile Tyr Pro Ile Leu Lys Gly
 165 170 175

Phe Arg Lys Thr Thr
 180

(2) INFORMATION FOR SEQ ID NO:75:

- (i) SEQUENCE CHARACTERISTICS:
 - (A) LENGTH: 85 amino acids
 - (B) TYPE: amino acid
 - (D) TOPOLOGY: linear

(ii) MOLECULE TYPE: peptide

(iii) HYPOTHETICAL: NO

(iv) ANTI-SENSE: NO

(v) FRAGMENT TYPE: internal

(xi) SEQUENCE DESCRIPTION: SEQ ID NO:75:

Ser Cys Phe Ala Leu Ile Ser Gly Thr Ala Asn Gln Val Lys Cys Tyr
 1 5 10 15

Arg Phe Arg Val Lys Lys Asn His Arg His Arg Tyr Glu Asn Cys Thr
 20 25 30

Thr Thr Trp Phe Thr Val Ala Asp Asn Gly Ala Glu Arg Gln Gly Gln
 35 40 45

Ala Gln Ile Leu Ile Thr Phe Gly Ser Pro Ser Gln Arg Gln Asp Phe
 50 55 60

Leu Lys His Val Pro Leu Pro Pro Gly Met Asn Ile Ser Gly Phe Thr
 65 70 75 80

Ala Ser Leu Asp Phe
 85

(2) INFORMATION FOR SEQ ID NO:76:

- (i) SEQUENCE CHARACTERISTICS:

100

- (A) LENGTH: 87 amino acids
- (B) TYPE: amino acid
- (D) TOPOLOGY: linear

(ii) MOLECULE TYPE: peptide

(iii) HYPOTHETICAL: NO

(iv) ANTI-SENSE: NO

(v) FRAGMENT TYPE: internal

(xi) SEQUENCE DESCRIPTION: SEQ ID NO:76:

Cys Pro Cys Leu Leu Ile Gly Thr Ser Gly Asn Gly Asn Gln Val Lys
1 5 10 15

Cys Tyr Ser Phe Arg Val Lys Arg Trp His Asp Arg Asp Lys Tyr His
 20 25 30

His Thr Thr Thr Trp Trp Ala Val Gly Gly Gln Gly Ser Glu Arg Pro
 35 40 45

Gly Asp Ala Thr Val Ile Val Thr Phe Lys Asp Gln Ser Gln Arg Ser
 50 55 60

His Phe Leu Gln Gln Val Pro Leu Pro Pro Gly Met Ser Ala His Gly
65 70 75 80

Val Thr Met Thr Val Asp Phe
 85

(2) INFORMATION FOR SEQ ID NO:77:

- (i) SEQUENCE CHARACTERISTICS:
 - (A) LENGTH: 84 amino acids
 - (B) TYPE: amino acid
 - (D) TOPOLOGY: linear

(ii) MOLECULE TYPE: peptide

(iii) HYPOTHETICAL: NO

(iv) ANTI-SENSE: NO

(v) FRAGMENT TYPE: internal

(xi) SEQUENCE DESCRIPTION: SEQ ID NO:77:

Pro Pro Val Ile Cys Leu Lys Gly Gly His Asn Gln Leu Lys Cys Leu
1 5 10 15

Arg Tyr Arg Leu Lys Ser Lys His Ser Ser Leu Phe Asp Cys Ile Ser
 20 25 30

101

Thr Thr Trp Ser Trp Val Asp Thr Thr Ser Thr Cys Arg Leu Gly Ser
 35 40 45
 Gly Arg Met Leu Ile Lys Phe Ala Asp Ser Glu Gln Arg Asp Lys Phe
 50 55 60
 Leu Ser Arg Val Pro Leu Pro Ser Thr Thr Gln Val Phe Leu Gly Asn
 65 70 75 80
 Phe Tyr Gly Leu

(2) INFORMATION FOR SEQ ID NO:78:

- (i) SEQUENCE CHARACTERISTICS:
 - (A) LENGTH: 84 amino acids
 - (B) TYPE: amino acid
 - (D) TOPOLOGY: linear

(ii) MOLECULE TYPE: peptide

(iii) HYPOTHETICAL: NO

(iv) ANTI-SENSE: NO

(v) FRAGMENT TYPE: internal

(xi) SEQUENCE DESCRIPTION: SEQ ID NO:78:

Pro Pro Val Ile Leu Val Arg Gly Gly Ala Asn Thr Leu Lys Cys Phe
 1 5 10 15
 Arg Asn Arg Ala Arg Val Arg Tyr Arg Gly Leu Phe Lys Tyr Phe Ser
 20 25 30
 Thr Thr Trp Ser Trp Val Ala Gly Asp Ser Thr Glu Arg Leu Gly Arg
 35 40 45
 Ser Arg Met Leu Ile Leu Phe Thr Ser Ala Cys Gln Arg Glu Lys Pro
 50 55 60
 Asp Glu Thr Val Lys Tyr Pro Lys Gly Val Asp Thr Ser Tyr Gly Asn
 65 70 75 80
 Leu Asp Ser Leu

(2) INFORMATION FOR SEQ ID NO:79:

- (i) SEQUENCE CHARACTERISTICS:
 - (A) LENGTH: 84 amino acids
 - (B) TYPE: amino acid
 - (D) TOPOLOGY: linear

(ii) MOLECULE TYPE: peptide

(iii) HYPOTHETICAL: NO

(iv) ANTI-SENSE: NO

(v) FRAGMENT TYPE: internal

(xi) SEQUENCE DESCRIPTION: SEQ ID NO:79:

Pro	Pro	Val	Val	Cys	Val	Lys	Gly	Gly	Ala	Asn	Gln	Leu	Lys	Cys	Leu
1				5					10					15	
Arg	Tyr	Arg	Leu	Lys	Ala	Ser	Thr	Gln	Val	Asp	Phe	Asp	Ser	Ile	Ser
			20					25					30		
Thr	Thr	Trp	His	Trp	Thr	Asp	Arg	Lys	Asn	Thr	Glu	Arg	Ile	Gly	Ser
		35					40					45			
Ala	Arg	Met	Leu	Val	Lys	Phe	Ile	Asp	Glu	Ala	Gln	Arg	Glu	Lys	Phe
	50					55					60				
Leu	Glu	Arg	Val	Ala	Leu	Pro	Arg	Ser	Val	Ser	Val	Phe	Leu	Gly	Gln
65					70					75					80
Phe	Asn	Gly	Ser												

(2) INFORMATION FOR SEQ ID NO:80:

(i) SEQUENCE CHARACTERISTICS:

(A) LENGTH: 84 amino acids

(B) TYPE: amino acid

(D) TOPOLOGY: linear

(ii) MOLECULE TYPE: peptide

(iii) HYPOTHETICAL: NO

(iv) ANTI-SENSE: NO

(v) FRAGMENT TYPE: internal

(xi) SEQUENCE DESCRIPTION: SEQ ID NO:80:

Thr	Pro	Ile	Val	Gln	Leu	Gln	Gly	Asp	Ser	Asn	Cys	Leu	Lys	Cys	Phe
1				5					10					15	
Arg	Tyr	Arg	Leu	Asn	Asp	Lys	Tyr	Lys	His	Leu	Phe	Glu	Leu	Ala	Ser
			20					25					30		
Ser	Thr	Trp	His	Trp	Ala	Ser	Pro	Glu	Ala	Pro	His	Lys	Asn	Ala	Ile
		35				40						45			
Val	Thr	Leu	Thr	Tyr	Ser	Ser	Glu	Glu	Gln	Arg	Gln	Gln	Phe	Leu	Asn
50						55					60				

103

Ser Val Lys Ile Pro Pro Thr Ile Arg His Lys Val Gly Phe Met Ser
 65 70 75 80

Leu His Leu Leu

(2) INFORMATION FOR SEQ ID NO:81:

- (i) SEQUENCE CHARACTERISTICS:
 (A) LENGTH: 84 amino acids
 (B) TYPE: amino acid
 (D) TOPOLOGY: linear

(ii) MOLECULE TYPE: peptide

(iii) HYPOTHETICAL: NO

(iv) ANTI-SENSE: NO

(v) FRAGMENT TYPE: internal

(xi) SEQUENCE DESCRIPTION: SEQ ID NO:81:

Thr Pro Ile Val Gln Phe Gln Gly Glu Ser Asn Cys Leu Lys Cys Phe
 1 5 10 15

Arg Tyr Arg Leu Asn Arg Asp His Arg His Leu Phe Asp Leu Ile Ser
 20 25 30

Ser Thr Trp His Trp Ala Ser Ser Lys Ala Pro His Lys His Ala Ile
 35 40 45

Val Thr Val Thr Tyr Asp Ser Glu Glu Gln Arg Gln Gln Phe Leu Asp
 50 55 60

Val Val Lys Ile Pro Pro Thr Ile Ser His Lys Leu Gly Phe Met Ser
 65 70 75 80

Leu His Leu Leu

(2) INFORMATION FOR SEQ ID NO:82:

- (i) SEQUENCE CHARACTERISTICS:
 (A) LENGTH: 80 amino acids
 (B) TYPE: amino acid
 (D) TOPOLOGY: linear

(ii) MOLECULE TYPE: peptide

(iii) HYPOTHETICAL: NO

(iv) ANTI-SENSE: NO

(v) FRAGMENT TYPE: internal

(xi) SEQUENCE DESCRIPTION: SEQ ID NO:82:

```

Thr Pro Ile Ile His Leu Lys Gly Asp Arg Asn Ser Leu Lys Cys Leu
1           5           10           15
Arg Tyr Arg Leu Arg Lys His Ser Asp His Tyr Arg Asp Ile Ser Ser
          20           25           30
Thr Trp His Trp Thr Gly Ala Gly Asn Glu Lys Thr Gly Ile Leu Thr
          35           40           45
Val Thr Tyr His Ser Glu Thr Gln Arg Thr Lys Phe Leu Asn Thr Val
          50           55           60
Ala Ile Pro Asp Ser Val Gln Ile Leu Val Gly Tyr Asn Thr Met Tyr
          65           70           75           80

```

(2) INFORMATION FOR SEQ ID NO:83:

(i) SEQUENCE CHARACTERISTICS:

- (A) LENGTH: 80 amino acids
- (B) TYPE: amino acid
- (D) TOPOLOGY: linear

(ii) MOLECULE TYPE: peptide

(iii) HYPOTHETICAL: NO

(iv) ANTI-SENSE: NO

(v) FRAGMENT TYPE: internal

(xi) SEQUENCE DESCRIPTION: SEQ ID NO:83:

```

Thr Pro Ile Val His Leu Lys Gly Asp Ala Asn Thr Leu Lys Cys Leu
1           5           10           15
Arg Tyr Arg Phe Lys Lys His Cys Thr Leu Tyr Thr Ala Val Ser Ser
          20           25           30
Thr Trp His Trp Thr Gly His Asn Tyr Lys His Lys Ser Ala Ile Val
          35           40           45
Thr Leu Thr Tyr Asp Ser Glu Trp Gln Arg Asp Gln Phe Leu Ser Gln
          50           55           60
Val Lys Ile Pro Lys Thr Ile Thr Val Ser Thr Gly Phe Met Ser Ile
          65           70           75           80

```

(2) INFORMATION FOR SEQ ID NO:84:

(i) SEQUENCE CHARACTERISTICS:

- (A) LENGTH: 81 amino acids

105

(B) TYPE: amino acid

(D) TOPOLOGY: linear

(ii) MOLECULE TYPE: peptide

(iii) HYPOTHETICAL: NO

(iv) ANTI-SENSE: NO

(v) FRAGMENT TYPE: internal

(xi) SEQUENCE DESCRIPTION: SEQ ID NO:84:

Ala Pro Ile Val His Leu Lys Gly Glu Ser Asn Ser Leu Lys Cys Leu
 1 5 10 15

Arg Tyr Arg Leu Lys Pro Tyr Asn Glu Leu Tyr Ser Ser Met Ser Ser
 20 25 30

Thr Trp His Trp Thr Ser Asp Asn Lys Asn Ser Lys Asn Gly Ile Val
 35 40 45

Thr Val Thr Phe Val Thr Gly Gln Gln Gln Gln Met Phe Leu Gly Thr
 50 55 60

Val Lys Ile Pro Pro Thr Val Gln Ile Ser Thr Gly Phe Met Thr Leu
 65 70 75 80

Val

(2) INFORMATION FOR SEQ ID NO:85:

(i) SEQUENCE CHARACTERISTICS:

(A) LENGTH: 21 amino acids

(B) TYPE: amino acid

(D) TOPOLOGY: linear

(ii) MOLECULE TYPE: peptide

(iii) HYPOTHETICAL: NO

(iv) ANTI-SENSE: NO

(v) FRAGMENT TYPE: internal

(xi) SEQUENCE DESCRIPTION: SEQ ID NO:85:

Gly Ile Val Glu Gln Cys Cys Thr Ser Ile Cys Ser Leu Tyr Gln Leu
 1 5 10 15

Glu Asn Tyr Cys Asn
 20

(2) INFORMATION FOR SEQ ID NO:86:

- (i) SEQUENCE CHARACTERISTICS:
(A) LENGTH: 30 amino acids
(B) TYPE: amino acid
(D) TOPOLOGY: linear
- (ii) MOLECULE TYPE: peptide
- (iii) HYPOTHETICAL: NO
- (iv) ANTI-SENSE: NO
- (v) FRAGMENT TYPE: internal
- (xi) SEQUENCE DESCRIPTION: SEQ ID NO:86:
- | | | | | | | | | | | | | | | | |
|-----|-----|-----|-----|-----|-----|-----|-----|-----|-----|-----|-----|-----|-----|-----|-----|
| Phe | Val | Asn | Gln | His | Leu | Cys | Gly | Ser | His | Leu | Val | Glu | Ala | Leu | Tyr |
| 1 | | | | 5 | | | | | 10 | | | | | 15 | |
| Leu | Val | Cys | Gly | Glu | Arg | Gly | Phe | Phe | Tyr | Thr | Pro | Lys | Thr | | |
| | | | 20 | | | | | 25 | | | | | 30 | | |

(2) INFORMATION FOR SEQ ID NO:87:

- (i) SEQUENCE CHARACTERISTICS:
(A) LENGTH: 21 amino acids
(B) TYPE: amino acid
(D) TOPOLOGY: linear
- (ii) MOLECULE TYPE: peptide
- (iii) HYPOTHETICAL: NO
- (iv) ANTI-SENSE: NO
- (v) FRAGMENT TYPE: internal
- (xi) SEQUENCE DESCRIPTION: SEQ ID NO:87:
- | | | | | | | | | | | | | | | | |
|-----|-----|-----|-----|-----|-----|-----|-----|-----|-----|-----|-----|-----|-----|-----|-----|
| Gly | Ile | Val | Glu | Gln | Cys | Cys | Ala | Ser | Val | Cys | Ser | Leu | Tyr | Gln | Leu |
| 1 | | | | 5 | | | | | 10 | | | | | 15 | |
| Glu | Asn | Tyr | Cys | Asn | | | | | | | | | | | |
| | | | | 20 | | | | | | | | | | | |

(2) INFORMATION FOR SEQ ID NO:88:

- (i) SEQUENCE CHARACTERISTICS:
(A) LENGTH: 30 amino acids
(B) TYPE: amino acid
(D) TOPOLOGY: linear
- (ii) MOLECULE TYPE: peptide
- (iii) HYPOTHETICAL: NO

(iv) ANTI-SENSE: NO

(v) FRAGMENT TYPE: internal

(xi) SEQUENCE DESCRIPTION: SEQ ID NO:88:

Phe Val Asn Gln His Leu Cys Gly Ser His Leu Val Glu Ala Leu Tyr
1 5 10 15

Leu Val Cys Gly Glu Arg Gly Phe Phe Tyr Thr Pro Lys Thr
 20 25 30

(2) INFORMATION FOR SEQ ID NO:89:

(i) SEQUENCE CHARACTERISTICS:
(A) LENGTH: 24 amino acids
(B) TYPE: amino acid
(D) TOPOLOGY: linear

(ii) MOLECULE TYPE: peptide

(iii) HYPOTHETICAL: NO

(iv) ANTI-SENSE: NO

(v) FRAGMENT TYPE: internal

(xi) SEQUENCE DESCRIPTION: SEQ ID NO:89:

Gln Leu Tyr Ser Ala Leu Ala Asn Lys Cys Cys His Val Gly Cys Ile
1 5 10 15

Lys Arg Ser Leu Ala Arg Phe Cys
 20

(2) INFORMATION FOR SEQ ID NO:90:

(i) SEQUENCE CHARACTERISTICS:
(A) LENGTH: 33 amino acids
(B) TYPE: amino acid
(D) TOPOLOGY: linear

(ii) MOLECULE TYPE: peptide

(iii) HYPOTHETICAL: NO

(iv) ANTI-SENSE: NO

(v) FRAGMENT TYPE: internal

(xi) SEQUENCE DESCRIPTION: SEQ ID NO:90:

```

Asp Ser Trp Met Glu Glu Val Ile Lys Ile Cys Gly Arg Glu Leu Val
1          5          10          15

Arg Ala Gln Ile Ala Ile Cys Gly Met Ser Thr Trp Ser Lys Arg Ser
          20          25          30

Leu
    
```

(2) INFORMATION FOR SEQ ID NO:91:

- (i) SEQUENCE CHARACTERISTICS:
 - (A) LENGTH: 24 amino acids
 - (B) TYPE: amino acid
 - (D) TOPOLOGY: linear
- (ii) MOLECULE TYPE: peptide
- (iii) HYPOTHETICAL: NO
- (iv) ANTI-SENSE: NO
- (v) FRAGMENT TYPE: internal
- (xi) SEQUENCE DESCRIPTION: SEQ ID NO:91:

```

Glu Glu Lys Met Gly Thr Ala Lys Lys Cys Cys Ala Ile Gly Cys Ser
1          5          10          15

Thr Glu Asp Phe Arg Met Val Cys
          20
    
```

(2) INFORMATION FOR SEQ ID NO:92:

- (i) SEQUENCE CHARACTERISTICS:
 - (A) LENGTH: 40 amino acids
 - (B) TYPE: amino acid
 - (D) TOPOLOGY: linear
- (ii) MOLECULE TYPE: peptide
- (iii) HYPOTHETICAL: NO
- (iv) ANTI-SENSE: NO
- (v) FRAGMENT TYPE: internal
- (xi) SEQUENCE DESCRIPTION: SEQ ID NO:92:

```

Arg Pro Asn Trp Glu Glu Arg Ser Arg Leu Cys Gly Arg Asp Leu Ile
1          5          10          15

Arg Ala Phe Ile Tyr Leu Cys Gly Gly Thr Arg Trp Thr Arg Leu Pro
          20          25          30
    
```

Asn Phe Gly Asn Tyr Pro Ile Met
35 40

(2) INFORMATION FOR SEQ ID NO:93:

- (i) SEQUENCE CHARACTERISTICS:
 (A) LENGTH: 182 amino acids
 (B) TYPE: amino acid
 (D) TOPOLOGY: linear

(ii) MOLECULE TYPE: peptide

(iii) HYPOTHETICAL: NO

(iv) ANTI-SENSE: NO

(v) FRAGMENT TYPE: internal

(xi) SEQUENCE DESCRIPTION: SEQ ID NO:93:

Ser Gly Ile Val Pro Thr Leu Gln Asn Ile Val Ser Thr Val Asn Leu
1 5 10 15
 Asp Cys Lys Leu Asp Leu Lys Ala Ile Ala Leu Gln Ala Arg Asn Ala
20 25 30
 Glu Tyr Asn Pro Lys Arg Phe Ala Ala Val Ile Met Arg Ile Arg Glu
35 40 45
 Pro Lys Thr Thr Ala Leu Ile Phe Ala Ser Gly Lys Met Val Cys Thr
50 55 60
 Gly Ala Lys Ser Glu Asp Phe Ser Lys Met Ala Ala Arg Lys Tyr Ala
65 70 75 80
 Arg Ile Val Gln Lys Leu Gly Phe Pro Ala Lys Phe Lys Asp Phe Lys
85 90 95
 Ile Gln Asn Ile Val Gly Ser Cys Asp Val Lys Phe Pro Ile Arg Leu
100 105 110
 Glu Gly Leu Ala Tyr Ser His Ala Ala Phe Ser Ser Tyr Glu Pro Glu
115 120 125
 Leu Phe Pro Gly Leu Ile Tyr Arg Met Lys Val Pro Lys Ile Val Leu
130 135 140
 Leu Ile Phe Val Ser Gly Lys Ile Val Ile Thr Gly Ala Lys Met Arg
145 150 155 160
 Asp Glu Thr Tyr Lys Ala Phe Glu Asn Ile Tyr Pro Val Leu Ser Glu
165 170 175
 Phe Arg Lys Ile Gln Gln
180

(2) INFORMATION FOR SEQ ID NO:94:

- (i) SEQUENCE CHARACTERISTICS:
 - (A) LENGTH: 84 amino acids
 - (B) TYPE: amino acid
 - (D) TOPOLOGY: linear
- (ii) MOLECULE TYPE: peptide
- (iii) HYPOTHETICAL: NO
- (iv) ANTI-SENSE: NO
- (v) FRAGMENT TYPE: internal
- (xi) SEQUENCE DESCRIPTION: SEQ ID NO:94:

```

Asn Ser Asn Ser Thr Pro Ile Val His Leu Lys Gly Asp Ala Asn Thr
 1           5           10           15
Leu Lys Cys Leu Arg Tyr Arg Phe Lys Lys His Cys Thr Leu Tyr Thr
          20           25           30
Ala Val Ser Ser Thr Trp His Trp Thr Gly His Asn Val Lys His Lys
          35           40           45
Ser Ala Ile Val Thr Leu Thr Tyr Asp Ser Glu Trp Gln Arg Asp Gln
          50           55           60
Phe Leu Ser Gln Val Lys Ile Pro Lys Thr Ile Thr Val Ser Thr Gly
65           70           75           80
Phe Met Ser Ile

```

(2) INFORMATION FOR SEQ ID NO:95:

- (i) SEQUENCE CHARACTERISTICS:
 - (A) LENGTH: 84 amino acids
 - (B) TYPE: amino acid
 - (D) TOPOLOGY: linear
- (ii) MOLECULE TYPE: peptide
- (iii) HYPOTHETICAL: NO
- (iv) ANTI-SENSE: NO
- (v) FRAGMENT TYPE: internal
- (xi) SEQUENCE DESCRIPTION: SEQ ID NO:95:

```

Asn Ser Asn Thr Thr Pro Ile Val His Leu Lys Gly Asp Ala Asn Thr
 1           5           10           15

```

111

Leu Lys Cys Leu Arg Tyr Arg Phe Lys Lys His Cys Thr Leu Tyr Thr
 20 25 30

Ala Val Ser Ser Thr Trp His Trp Thr Gly His Asn Val Lys His Lys
 35 40 45

Ser Ala Ile Val Thr Leu Thr Tyr Asp Ser Glu Trp Gln Arg Asp Gln
 50 55 60

Phe Leu Ser Gln Val Lys Ile Pro Lys Thr Ile Thr Val Ser Thr Gly
 65 70 75 80

Phe Met Ser Ile

(2) INFORMATION FOR SEQ ID NO:96:

- (i) SEQUENCE CHARACTERISTICS:
 - (A) LENGTH: 83 amino acids
 - (B) TYPE: amino acid
 - (D) TOPOLOGY: linear

(ii) MOLECULE TYPE: peptide

(iii) HYPOTHETICAL: NO

(iv) ANTI-SENSE: NO

(v) FRAGMENT TYPE: internal

(xi) SEQUENCE DESCRIPTION: SEQ ID NO:96:

Ser Gly Asn Thr Thr Pro Ile Ile His Leu Lys Gly Asp Arg Asn Ser
 1 5 10 15

Leu Lys Cys Leu Arg Tyr Arg Leu Arg Lys His Ser Asp His Tyr Arg
 20 25 30

Asp Ile Ser Ser Thr Trp His Trp Thr Gly Ala Gly Asn Glu Lys Thr
 35 40 45

Gly Ile Leu Thr Val Thr Tyr His Ser Glu Thr Gln Arg Thr Lys Phe
 50 55 60

Leu Asn Thr Val Ala Ile Pro Asp Ser Val Gln Ile Leu Val Gly Tyr
 65 70 75 80

Met Thr Met

(2) INFORMATION FOR SEQ ID NO:97:

- (i) SEQUENCE CHARACTERISTICS:
 - (A) LENGTH: 84 amino acids
 - (B) TYPE: amino acid

(D) TOPOLOGY: linear

(ii) MOLECULE TYPE: peptide

(iii) HYPOTHETICAL: NO

(iv) ANTI-SENSE: NO

(v) FRAGMENT TYPE: internal

(xi) SEQUENCE DESCRIPTION: SEQ ID NO:97:

Ser Gly Asn Thr Ala Pro Ile Val His Leu Lys Gly Glu Ser Asn Ser
 1 5 10 15

Leu Lys Cys Leu Arg Tyr Arg Leu Lys Pro Tyr Lys Glu Leu Tyr Ser
 20 25 30

Ser Met Ser Ser Thr Trp His Trp Thr Ser Asp Asn Lys Asn Ser Lys
 35 40 45

Asn Gly Ile Val Thr Val Thr Phe Val Thr Glu Gln Gln Gln Gln Met
 50 55 60

Phe Leu Gly Thr Val Lys Ile Pro Pro Thr Val Gln Ile Ser Thr Gly
 65 70 75 80

Phe Met Thr Leu

(2) INFORMATION FOR SEQ ID NO:98:

(i) SEQUENCE CHARACTERISTICS:

- (A) LENGTH: 89 amino acids
- (B) TYPE: amino acid
- (D) TOPOLOGY: linear

(ii) MOLECULE TYPE: peptide

(iii) HYPOTHETICAL: NO

(iv) ANTI-SENSE: NO

(v) FRAGMENT TYPE: internal

(xi) SEQUENCE DESCRIPTION: SEQ ID NO:98:

Ser Gly Asn Thr Ser Cys Phe Ala Leu Ile Ser Gly Thr Ala Asn Gln
 1 5 10 15

Val Lys Cys Tyr Arg Phe Arg Val Lys Lys Asn His Arg His Arg Tyr
 20 25 30

Glu Asn Cys Thr Thr Thr Trp Phe Thr Val Ala Asp Asn Gly Ala Glu
 35 40 45

Arg Gln Gly Gln Ala Gln Ile Leu Ile Thr Phe Gly Ser Pro Ser Gln
 50 55 60

Arg Gln Asp Phe Leu Lys His Val Pro Leu Pro Pro Gly Met Asn Ile
 65 70 75 80

Ser Gly Phe Thr Ala Ser Leu Asp Phe
 85

(2) INFORMATION FOR SEQ ID NO:99:

- (i) SEQUENCE CHARACTERISTICS:
 - (A) LENGTH: 7 amino acids
 - (B) TYPE: amino acid
 - (D) TOPOLOGY: linear

(ii) MOLECULE TYPE: peptide

(iii) HYPOTHETICAL: NO

(iv) ANTI-SENSE: NO

(v) FRAGMENT TYPE: C-terminal

(xi) SEQUENCE DESCRIPTION: SEQ ID NO:99:

Ser Asn Lys Lys Thr Thr Ala
 1 5

(2) INFORMATION FOR SEQ ID NO:100:

- (i) SEQUENCE CHARACTERISTICS:
 - (A) LENGTH: 4 amino acids
 - (B) TYPE: amino acid
 - (D) TOPOLOGY: linear

(ii) MOLECULE TYPE: peptide

(iii) HYPOTHETICAL: NO

(iv) ANTI-SENSE: NO

(v) FRAGMENT TYPE: internal

(xi) SEQUENCE DESCRIPTION: SEQ ID NO:100:

Asn Ser Asn Thr
 1

(2) INFORMATION FOR SEQ ID NO:101:

- (i) SEQUENCE CHARACTERISTICS:
 - (A) LENGTH: 4 amino acids

(B) TYPE: amino acid
(D) TOPOLOGY: linear

- (ii) MOLECULE TYPE: peptide
(iii) HYPOTHETICAL: NO
(iv) ANTI-SENSE: NO
(v) FRAGMENT TYPE: internal
(xi) SEQUENCE DESCRIPTION: SEQ ID NO:101:

Ser Gly Asn Thr
1

(2) INFORMATION FOR SEQ ID NO:102:

(i) SEQUENCE CHARACTERISTICS:
(A) LENGTH: 6 amino acids
(B) TYPE: amino acid
(D) TOPOLOGY: linear

- (ii) MOLECULE TYPE: peptide
(iii) HYPOTHETICAL: NO
(iv) ANTI-SENSE: NO
(v) FRAGMENT TYPE: internal
(xi) SEQUENCE DESCRIPTION: SEQ ID NO:102:

Ser Ser Gly Ser Ser Gly
1 5

(2) INFORMATION FOR SEQ ID NO:103:

(i) SEQUENCE CHARACTERISTICS:
(A) LENGTH: 15 amino acids
(B) TYPE: amino acid
(D) TOPOLOGY: linear

- (ii) MOLECULE TYPE: peptide
(iii) HYPOTHETICAL: NO
(iv) ANTI-SENSE: NO
(v) FRAGMENT TYPE: internal
(xi) SEQUENCE DESCRIPTION: SEQ ID NO:103:

Cys Tyr Pro Glu Ile Lys Asp Lys Glu Glu Val Gln Arg Lys Arg
1 5 10 15

116

Thr Lys Thr Ala Lys Asp Leu Gly Val Tyr Gln Ser Ala Ile Asn Lys
 20 25 30

Ala Ile His Ala Gly Arg Lys Ile Phe Leu Thr Ile Asn Ala Asp Gly
 35 40 45

Ser Val Tyr Ala Glu Glu Val Lys Pro Phe Pro Ser Asn Lys Lys Thr
 50 55 60

Thr Ala
 65

(2) INFORMATION FOR SEQ ID NO:106:

- (i) SEQUENCE CHARACTERISTICS:
 - (A) LENGTH: 66 amino acids
 - (B) TYPE: amino acid
 - (D) TOPOLOGY: linear
- (ii) MOLECULE TYPE: protein
- (iii) HYPOTHETICAL: NO
- (iv) ANTI-SENSE: NO
- (v) FRAGMENT TYPE: N-terminal
- (xi) SEQUENCE DESCRIPTION: SEQ ID NO:106:

Met Arg Gln Arg Ile Thr Leu Lys Asp Tyr Ala Met Arg Phe Gly Gln
 1 5 10 15

Thr Lys Thr Ala Lys Asp Leu Gly Val Tyr Gln Ser Ala Ile Asn Lys
 20 25 30

Ala Ile His Ala Gly Arg Lys Ile Phe Leu Thr Ile Asn Ala Asp Gly
 35 40 45

Ser Val Tyr Ala Glu Glu Val Lys Pro Phe Pro Ser Asn Lys Lys Thr
 50 55 60

Thr Ala
 65

(2) INFORMATION FOR SEQ ID NO:107:

- (i) SEQUENCE CHARACTERISTICS:
 - (A) LENGTH: 96 amino acids
 - (B) TYPE: amino acid
 - (D) TOPOLOGY: linear
- (ii) MOLECULE TYPE: peptide
- (iii) HYPOTHETICAL: NO

117

(iv) ANTI-SENSE: NO

(v) FRAGMENT TYPE: N-terminal

(xi) SEQUENCE DESCRIPTION: SEQ ID NO:107:

```

Ser Thr Lys Lys Lys Pro Leu Thr Gln Glu Gln Leu Glu Asp Ala Arg
 1           5           10           15
Arg Leu Lys Ala Ile Tyr Glu Lys Lys Lys Asn Glu Leu Gly Leu Ser
           20           25           30
Gln Glu Ser Val Ala Asp Lys Met Gly Met Gly Gln Ser Gly Val Gly
           35           40           45
Ala Leu Phe Asn Gly Ile Asn Ala Leu Asn Ala Tyr Asn Ala Ala Leu
 50           55           60
Leu Ala Lys Ile Leu Lys Val Ser Val Glu Glu Phe Ser Pro Ser Ile
65           70           75           80
Ala Arg Glu Ile Tyr Glu Met Tyr Glu Ala Val Ser Met Glu Pro Ser
           85           90           95

```

(2) INFORMATION FOR SEQ ID NO:108:

(i) SEQUENCE CHARACTERISTICS:

- (A) LENGTH: 96 amino acids
- (B) TYPE: amino acid
- (D) TOPOLOGY: linear

(ii) MOLECULE TYPE: peptide

(iii) HYPOTHETICAL: NO

(iv) ANTI-SENSE: NO

(v) FRAGMENT TYPE: N-terminal

(xi) SEQUENCE DESCRIPTION: SEQ ID NO:108:

```

Ser Thr Lys Lys Lys Pro Leu Thr Gln Glu Gln Leu Glu Asp Ala Arg
 1           5           10           15
Arg Leu Lys Ala Ile Tyr Glu Lys Lys Lys Asn Glu Leu Gly Leu Ser
           20           25           30
Gln Glu Ser Val Ala Asp Lys Met Gly Met Gly Gln Ser Gly Val Gly
           35           40           45
Ala Leu Phe Asn Gly Ile Asn Ala Leu Asn Ala Tyr Asn Ala Ala Leu
 50           55           60
Leu Ala Lys Ile Leu Lys Val Ser Val Glu Glu Phe Ser Pro Ser Ile
65           70           75           80

```

Ala Arg Glu Ile Tyr Glu Met Cys Glu Ala Val Ser Met Glu Pro Ser
 85 90 95

(2) INFORMATION FOR SEQ ID NO:109:

- (i) SEQUENCE CHARACTERISTICS:
 - (A) LENGTH: 180 amino acids
 - (B) TYPE: amino acid
 - (D) TOPOLOGY: linear

(ii) MOLECULE TYPE: protein

(iii) HYPOTHETICAL: NO

(iv) ANTI-SENSE: NO

(v) FRAGMENT TYPE: N-terminal

(xi) SEQUENCE DESCRIPTION: SEQ ID NO:109:

Gly Ile Val Glu Gln Cys Cys Thr Ser Ile Cys Ser Leu Tyr Gln Leu
 1 5 10 15

Glu Asn Tyr Cys Asn Met Ser Met Glu Gln Arg Ile Thr Leu Lys Asp
 20 25 30

Tyr Ala Met Arg Phe Gly Gln Thr Lys Thr Ala Lys Asp Leu Gly Val
 35 40 45

Tyr Gln Ser Ala Ile Asn Lys Ala Ile His Ala Gly Arg Lys Ile Phe
 50 55 60

Leu Thr Ile Asn Ala Asp Gly Ser Val Tyr Ala Glu Glu Val Lys Pro
 65 70 75 80

Phe Pro Ser Asn Lys Lys Thr Thr Ala Ser Asn Lys Lys Thr Thr Ala
 85 90 95

Asn Ser Asn Thr Thr Pro Ile Val His Leu Lys Gly Asp Ala Asn Thr
 100 105 110

Leu Lys Cys Leu Arg Tyr Arg Phe Lys Lys His Cys Thr Leu Tyr Thr
 115 120 125

Ala Val Ser Ser Thr Trp His Trp Thr Gly His Asn Val Lys His Lys
 130 135 140

Ser Ala Ile Val Thr Leu Thr Tyr Asp Ser Glu Trp Gln Arg Asp Gln
 145 150 155 160

Phe Leu Ser Gln Val Lys Ile Pro Lys Thr Ile Thr Val Ser Thr Gly
 165 170 175

Phe Met Ser Ile
 180

(2) INFORMATION FOR SEQ ID NO:110:

- (i) SEQUENCE CHARACTERISTICS:
 (A) LENGTH: 113 amino acids
 (B) TYPE: amino acid
 (D) TOPOLOGY: linear
- (ii) MOLECULE TYPE: protein
- (iii) HYPOTHETICAL: NO
- (iv) ANTI-SENSE: NO
- (v) FRAGMENT TYPE: N-terminal
- (xi) SEQUENCE DESCRIPTION: SEQ ID NO:110:
- | | | | | | | | | | | | | | | | |
|-----|-----|-----|-----|-----|-----|-----|-----|-----|-----|-----|-----|-----|-----|-----|-----|
| Gly | Ile | Val | Glu | Gln | Cys | Cys | Thr | Ser | Ile | Cys | Ser | Leu | Tyr | Gln | Leu |
| 1 | | | | 5 | | | | | 10 | | | | | 15 | |
| Glu | Asn | Tyr | Cys | Asn | Met | Ser | Met | Glu | Gln | Arg | Ile | Thr | Leu | Lys | Asp |
| | | | 20 | | | | | 25 | | | | | 30 | | |
| Tyr | Ala | Met | Arg | Phe | Gly | Gln | Thr | Lys | Thr | Ala | Lys | Asp | Leu | Gly | Val |
| | | 35 | | | | | 40 | | | | | 45 | | | |
| Tyr | Gln | Ser | Ala | Ile | Asn | Lys | Ala | Ile | His | Ala | Gly | Arg | Lys | Ile | Phe |
| | 50 | | | | | 55 | | | | | 60 | | | | |
| Leu | Thr | Ile | Asn | Ala | Asp | Gly | Ser | Val | Tyr | Ala | Glu | Glu | Val | Lys | Pro |
| 65 | | | | | 70 | | | | | 75 | | | | 80 | |
| Phe | Pro | Ser | Asn | Lys | Lys | Thr | Thr | Ala | Ser | Asn | Lys | Lys | Thr | Thr | Ala |
| | | | | 85 | | | | | 90 | | | | | 95 | |
| Cys | Asp | Thr | Asp | Asp | Arg | His | Arg | Ile | Glu | Glu | Lys | Arg | Lys | Arg | Lys |
| | | | 100 | | | | | 105 | | | | | | 110 | |
- Thr

(2) INFORMATION FOR SEQ ID NO:111:

- (i) SEQUENCE CHARACTERISTICS:
 (A) LENGTH: 292 amino acids
 (B) TYPE: amino acid
 (D) TOPOLOGY: linear
- (ii) MOLECULE TYPE: protein
- (iii) HYPOTHETICAL: NO
- (iv) ANTI-SENSE: NO
- (v) FRAGMENT TYPE: N-terminal

120

(xi) SEQUENCE DESCRIPTION: SEQ ID NO:111:

Phe	Val	Asn	Gln	His	Leu	Cys	Gly	Ser	His	Leu	Val	Glu	Ala	Leu	Tyr	1	5	10	15
Leu	Val	Cys	Gly	Glu	Arg	Gly	Phe	Phe	Tyr	Thr	Pro	Lys	Thr	Met	Ser	20	25	30	
Met	Glu	Gln	Glu	Ile	Thr	Leu	Lys	Asp	Tyr	Ala	Met	Arg	Phe	Gly	Gln	35	40	45	
Thr	Lys	Thr	Ala	Lys	Asp	Leu	Gly	Val	Tyr	Gln	Ser	Ala	Ile	Asn	Lys	50	55	60	
Ala	Ile	His	Ala	Gly	Arg	Lys	Ile	Phe	Leu	Thr	Ile	Asn	Ala	Asp	Gly	65	70	75	80
Ser	Val	Tyr	Ala	Glu	Glu	Val	Lys	Pro	Phe	Pro	Ser	Asn	Lys	Lys	Thr	85	90	95	
Thr	Ala	Ser	Asn	Lys	Lys	Thr	Thr	Ala	Ser	Ser	Gly	Ser	Ser	Gly	Ser	100	105	110	
Gly	Ile	Val	Pro	Gln	Leu	Gln	Asn	Ile	Val	Ser	Thr	Val	Asn	Leu	Gly	115	120	125	
Cys	Lys	Leu	Asp	Leu	Lys	Thr	Ile	Ala	Leu	Arg	Ala	Arg	Asn	Ala	Glu	130	135	140	
Tyr	Asn	Pro	Lys	Arg	Phe	Ala	Ala	Val	Ile	Met	Arg	Ile	Arg	Glu	Pro	145	150	155	160
Arg	Thr	Thr	Ala	Leu	Ile	Phe	Ser	Ser	Gly	Lys	Met	Val	Cys	Thr	Gly	165	170	175	
Ala	Lys	Ser	Glu	Glu	Gln	Ser	Arg	Leu	Ala	Ala	Arg	Lys	Tyr	Ala	Arg	180	185	190	
Val	Val	Gln	Lys	Leu	Gly	Phe	Pro	Ala	Lys	Phe	Leu	Asp	Phe	Lys	Ile	195	200	205	
Gln	Asn	Met	Val	Gly	Ser	Cys	Asp	Val	Lys	Phe	Pro	Ile	Arg	Leu	Glu	210	215	220	
Gly	Leu	Val	Leu	Thr	His	Gln	Gln	Phe	Ser	Ser	Tyr	Glu	Pro	Glu	Leu	225	230	235	240
Phe	Pro	Gly	Leu	Ile	Tyr	Arg	Met	Ile	Lys	Pro	Arg	Ile	Val	Leu	Leu	245	250	255	
Ile	Phe	Val	Ser	Gly	Lys	Val	Val	Leu	Thr	Gly	Ala	Lys	Val	Arg	Ala	260	265	270	
Glu	Ile	Tyr	Glu	Ala	Phe	Glu	Asn	Ile	Tyr	Pro	Ile	Leu	Lys	Gly	Phe	275	280	285	

Arg Lys Thr Thr
290

(2) INFORMATION FOR SEQ ID NO:112:

- (i) SEQUENCE CHARACTERISTICS:
 (A) LENGTH: 273 amino acids
 (B) TYPE: amino acid
 (D) TOPOLOGY: linear

(ii) MOLECULE TYPE: protein

(iii) HYPOTHETICAL: NO

(iv) ANTI-SENSE: NO

(v) FRAGMENT TYPE: N-terminal

(xi) SEQUENCE DESCRIPTION: SEQ ID NO:112:

Phe	Val	Asn	Gln	His	Leu	Cys	Gly	Ser	His	Leu	Val	Glu	Ala	Leu	Tyr	1	5	10	15
Leu	Val	Cys	Gly	Glu	Arg	Gly	Phe	Phe	Tyr	Thr	Pro	Lys	Thr	Met	Ser	20	25	30	
Met	Arg	Gln	Arg	Ile	Thr	Leu	Lys	Asp	Tyr	Ala	Met	Arg	Phe	Gly	Gln	35	40	45	
Thr	Lys	Thr	Ala	Lys	Asp	Leu	Gly	Val	Tyr	Gln	Ser	Ala	Ile	Asn	Lys	50	55	60	
Ala	Ile	His	Ala	Gly	Arg	Lys	Ile	Phe	Leu	Thr	Ile	Asn	Ala	Asp	Gly	65	70	75	80
Ser	Val	Tyr	Ala	Glu	Glu	Val	Lys	Pro	Phe	Pro	Ser	Asn	Lys	Lys	Thr	85	90	95	
Thr	Ala	Ser	Asn	Lys	Lys	Thr	Thr	Ala	Gly	Asp	Pro	Gly	Lys	Lys	Lys	100	105	110	
Gln	His	Ile	Cys	His	Ile	Gln	Gly	Cys	Gly	Lys	Val	Tyr	Gly	Lys	Thr	115	120	125	
Ser	His	Leu	Arg	Ala	His	Leu	Arg	Trp	His	Thr	Gly	Glu	Arg	Pro	Phe	130	135	140	
Met	Cys	Thr	Trp	Ser	Tyr	Cys	Gly	Lys	Arg	Phe	Thr	Arg	Ser	Asp	Glu	145	150	155	160
Leu	Gln	Arg	His	Lys	Arg	Thr	His	Thr	Gly	Glu	Lys	Lys	Phe	Ala	Cys	165	170	175	
Pro	Glu	Cys	Pro	Lys	Arg	Phe	Met	Arg	Ser	Asp	His	Leu	Ser	Lys	His	180	185	190	

122

Ile Lys Thr His Gln Asn Lys Lys Gly Gly Pro Gly Val Ala Leu Ser
 195 200 205

Val Gly Thr Leu Pro Leu Asp Ser Gly Ala Gly Ser Glu Gly Ser Gly
 210 215 220

Thr Ala Thr Pro Ser Ala Leu Ile Thr Thr Asn Met Val Ala Met Glu
 225 230 235 240

Ala Ile Cys Pro Glu Gly Ile Ala Arg Leu Ala Asn Ser Gly Ile Asn
 245 250 255

Val Met Gln Val Ala Asp Leu Gln Ser Ile Asn Ile Ser Gly Asn Gly
 260 265 270

Phe

(2) INFORMATION FOR SEQ ID NO:113:

- (i) SEQUENCE CHARACTERISTICS:
 - (A) LENGTH: 421 amino acids
 - (B) TYPE: amino acid
 - (D) TOPOLOGY: linear
- (ii) MOLECULE TYPE: protein
- (iii) HYPOTHETICAL: NO
- (iv) ANTI-SENSE: NO
- (v) FRAGMENT TYPE: N-terminal
- (xi) SEQUENCE DESCRIPTION: SEQ ID NO:113:

Gln Leu Tyr Ser Ala Leu Ala Asn Lys Cys Cys His Val Gly Cys Ile
 1 5 10 15

Lys Arg Ser Leu Ala Arg Phe Cys Met Ser Met Arg Gln Arg Ile Thr
 20 25 30

Leu Lys Asp Tyr Ala Met Arg Phe Gly Gln Thr Lys Thr Ala Lys Asp
 35 40 45

Leu Gly Val Tyr Gln Ser Ala Ile Asn Lys Ala Ile His Ala Gly Arg
 50 55 60

Lys Ile Phe Leu Thr Ile Asn Ala Asp Gly Ser Val Tyr Ala Glu Glu
 65 70 75 80

Val Lys Pro Phe Pro Ser Asn Lys Lys Thr Thr Ala Ser Asn Lys Lys
 85 90 95

Thr Thr Ala Met Ala Asp Asp Asp Pro Tyr Gly Thr Gly Gln Met Phe
 100 105 110

123

His Leu Asn Thr Ala Leu Thr His Ser Ile Phe Asn Ala Glu Leu Tyr
 115 120 125

Ser Pro Glu Ile Pro Leu Ser Thr Asp Gly Pro Tyr Leu Gln Ile Leu
 130 135 140

Glu Gln Pro Lys Gln Arg Gly Phe Arg Phe Arg Tyr Val Cys Glu Gly
 145 150 155 160

Pro Ser His Gly Gly Leu Pro Gly Ala Ser Ser Glu Lys Asn Lys Lys
 165 170 175

Ser Tyr Pro Gln Val Lys Ile Cys Asn Tyr Val Gly Pro Ala Lys Val
 180 185 190

Ile Val Gln Leu Val Thr Asn Gly Lys Asn Ile His Leu His Ala His
 195 200 205

Ser Leu Val Gly Lys His Cys Glu Asp Gly Val Cys Thr Val Thr Ala
 210 215 220

Gly Pro Lys Asp Met Val Val Gly Phe Ala Asn Leu Gly Ile Leu His
 225 230 235 240

Val Thr Lys Lys Lys Val Phe Glu Thr Leu Glu Ala Arg Met Thr Glu
 245 250 255

Ala Cys Ile Arg Gly Tyr Asn Pro Gly Leu Leu Val His Ser Asp Leu
 260 265 270

Ala Tyr Leu Gln Ala Glu Gly Gly Gly Asp Arg Gln Leu Thr Asp Arg
 275 280 285

Glu Lys Glu Ile Ile Arg Gln Ala Ala Val Gln Gln Thr Lys Glu Met
 290 295 300

Asp Leu Ser Val Val Arg Leu Met Phe Thr Ala Phe Leu Pro Asp Ser
 305 310 315 320

Thr Gly Ser Phe Thr Arg Arg Leu Glu Pro Val Val Ser Asp Ala Ile
 325 330 335

Tyr Asp Ser Lys Ala Pro Asn Ala Ser Asn Leu Lys Ile Val Arg Met
 340 345 350

Asp Arg Thr Ala Gly Cys Val Thr Gly Gly Glu Glu Ile Tyr Leu Leu
 355 360 365

Cys Asp Lys Val Gln Lys Asp Asp Ile Gln Ile Arg Phe Tyr Glu Glu
 370 375 380

Glu Glu Asn Gly Gly Val Trp Glu Gly Phe Gly Asp Phe Ser Pro Thr
 385 390 395 400

Asp Val His Arg Gln Phe Ala Ile Val Phe Lys Thr Pro Lys Tyr Lys
 405 410 415

Asp Val Asn Ile Thr
420

(2) INFORMATION FOR SEQ ID NO:114:

- (i) SEQUENCE CHARACTERISTICS:
 - (A) LENGTH: 391 amino acids
 - (B) TYPE: amino acid
 - (D) TOPOLOGY: linear

(ii) MOLECULE TYPE: protein

(iii) HYPOTHETICAL: NO

(iv) ANTI-SENSE: NO

(v) FRAGMENT TYPE: N-terminal

(xi) SEQUENCE DESCRIPTION: SEQ ID NO:114:

Met	Arg	Gln	Arg	Ile	Thr	Leu	Lys	Asp	Tyr	Ala	Met	Arg	Phe	Gly	Gln
1				5					10					15	
Thr	Lys	Thr	Ala	Lys	Asp	Leu	Gly	Val	Tyr	Gln	Ser	Ala	Ile	Asn	Lys
			20					25					30		
Ala	Ile	His	Ala	Gly	Arg	Lys	Ile	Phe	Leu	Thr	Ile	Asn	Ala	Asp	Gly
		35					40					45			
Ser	Val	Tyr	Ala	Glu	Glu	Val	Lys	Pro	Phe	Pro	Ser	Asn	Lys	Lys	Thr
	50					55					60				
Thr	Ala	Met	Ala	Glu	Asp	Asp	Pro	Tyr	Leu	Gly	Arg	Pro	Glu	Gln	Met
65					70					75					80
Phe	His	Leu	Asp	Pro	Ser	Leu	Thr	His	Thr	Ile	Phe	Asn	Pro	Glu	Val
				85					90					95	
Phe	Gln	Pro	Gln	Met	Ala	Leu	Pro	Thr	Ala	Asp	Gly	Pro	Tyr	Leu	Gln
			100					105					110		
Ile	Leu	Glu	Gln	Pro	Lys	Gln	Arg	Gly	Phe	Arg	Phe	Arg	Tyr	Val	Cys
		115					120					125			
Glu	Gly	Pro	Ser	His	Gly	Gly	Leu	Pro	Gly	Ala	Ser	Ser	Glu	Lys	Asn
	130						135				140				
Lys	Lys	Ser	Tyr	Pro	Gln	Val	Lys	Ile	Cys	Asn	Tyr	Val	Gly	Pro	Ala
145					150					155					160
Lys	Val	Ile	Val	Gln	Leu	Val	Thr	Asn	Gly	Lys	Asn	Ile	His	Leu	His
				165					170					175	
Ala	His	Ser	Leu	Val	Gly	Lys	His	Cys	Glu	Asp	Gly	Ile	Cys	Thr	Val
			180					185					190		

125

Thr Ala Gly Pro Glu Asp Cys Val His Gly Phe Ala Asn Leu Gly Ile
 195 200 205
 Leu His Val Thr Lys Lys Lys Val Phe Glu Thr Leu Glu Ala Arg Met
 210 215 220
 Thr Glu Ala Cys Ile Arg Gly Tyr Asn Pro Gly Leu Leu Val His Pro
 225 230 235 240
 Asp Leu Ala Tyr Leu Gln Ala Glu Gly Gly Gly Asp Arg Gln Leu Gly
 245 250 255
 Asp Arg Glu Lys Glu Leu Ile Arg Gln Ala Ala Leu Gln Gln Thr Lys
 260 265 270
 Glu Met Asp Leu Ser Val Val Arg Leu Met Phe Thr Ala Phe Leu Pro
 275 280 285
 Asp Ser Thr Gly Ser Phe Thr Arg Arg Leu Glu Pro Val Val Ser Asp
 290 295 300
 Ala Ile Tyr Asp Ser Lys Ala Pro Asn Ala Ser Asn Leu Lys Ile Val
 305 310 315 320
 Arg Met Asp Arg Thr Ala Gly Cys Val Thr Gly Gly Glu Glu Ile Tyr
 325 330 335
 Leu Leu Cys Asp Lys Val Gln Lys Asp Asp Ile Gln Ile Arg Phe Tyr
 340 345 350
 Glu Glu Glu Glu Asn Gly Gly Val Trp Glu Gly Phe Gly Asp Phe Ser
 355 360 365
 Pro Thr Asp Val His Arg Gln Phe Ala Ile Val Phe Lys Thr Pro Lys
 370 375 380
 Tyr Lys Asp Ile Asn Ile Thr
 385 390

(2) INFORMATION FOR SEQ ID NO:115:

(i) SEQUENCE CHARACTERISTICS:

- (A) LENGTH: 391 amino acids
- (B) TYPE: amino acid
- (D) TOPOLOGY: linear

(ii) MOLECULE TYPE: protein

(iii) HYPOTHETICAL: NO

(iv) ANTI-SENSE: NO

(v) FRAGMENT TYPE: N-terminal

(xi) SEQUENCE DESCRIPTION: SEQ ID NO:115:

Met	Glu	Gln	Glu	Ile	Thr	Leu	Lys	Asp	Tyr	Ala	Met	Arg	Phe	Gly	Gln	1	5	10	15
Thr	Lys	Thr	Ala	Lys	Asp	Leu	Gly	Val	Tyr	Gln	Ser	Ala	Ile	Asn	Lys	20	25	30	
Ala	Ile	His	Ala	Gly	Arg	Lys	Ile	Phe	Leu	Thr	Ile	Asn	Ala	Asp	Gly	35	40	45	
Ser	Val	Tyr	Ala	Glu	Glu	Val	Lys	Pro	Phe	Pro	Ser	Asn	Lys	Lys	Thr	50	55	60	
Thr	Ala	Met	Ala	Glu	Asp	Asp	Pro	Tyr	Leu	Gly	Arg	Pro	Glu	Gln	Met	65	70	75	80
Phe	His	Leu	Asp	Pro	Ser	Leu	Thr	His	Thr	Ile	Phe	Asn	Pro	Glu	Val	85	90	95	
Phe	Gln	Pro	Gln	Met	Ala	Leu	Pro	Thr	Ala	Asp	Gly	Pro	Tyr	Leu	Gln	100	105	110	
Ile	Leu	Glu	Gln	Pro	Lys	Gln	Arg	Gly	Phe	Arg	Phe	Arg	Tyr	Val	Cys	115	120	125	
Glu	Gly	Pro	Ser	His	Gly	Gly	Leu	Pro	Gly	Ala	Ser	Ser	Glu	Lys	Asn	130	135	140	
Lys	Lys	Ser	Tyr	Pro	Gln	Val	Lys	Ile	Cys	Asn	Tyr	Val	Gly	Pro	Ala	145	150	155	160
Lys	Val	Ile	Val	Gln	Leu	Val	Thr	Asn	Gly	Lys	Asn	Ile	His	Leu	His	165	170	175	
Ala	His	Ser	Leu	Val	Gly	Lys	His	Cys	Glu	Asp	Gly	Ile	Cys	Thr	Val	180	185	190	
Thr	Ala	Gly	Pro	Glu	Asp	Cys	Val	His	Gly	Phe	Ala	Asn	Leu	Gly	Ile	195	200	205	
Leu	His	Val	Thr	Lys	Lys	Lys	Val	Phe	Glu	Thr	Leu	Glu	Ala	Arg	Met	210	215	220	
Thr	Glu	Ala	Cys	Ile	Arg	Gly	Tyr	Asn	Pro	Gly	Leu	Leu	Val	His	Pro	225	230	235	240
Asp	Leu	Ala	Tyr	Leu	Gln	Ala	Glu	Gly	Gly	Gly	Asp	Arg	Gln	Leu	Gly	245	250	255	
Asp	Arg	Glu	Lys	Glu	Leu	Ile	Arg	Gln	Ala	Ala	Leu	Gln	Gln	Thr	Lys	260	265	270	
Glu	Met	Asp	Leu	Ser	Val	Val	Arg	Leu	Met	Phe	Thr	Ala	Phe	Leu	Pro	275	280	285	

127

Asp Ser Thr Gly Ser Phe Thr Arg Arg Leu Glu Pro Val Val Ser Asp
 290 295 300
 Ala Ile Tyr Asp Ser Lys Ala Pro Asn Ala Ser Asn Leu Lys Ile Val
 305 310 315 320
 Arg Met Asp Arg Thr Ala Gly Cys Val Thr Gly Gly Glu Glu Ile Tyr
 325 330 335
 Leu Leu Cys Asp Lys Val Gln Lys Asp Asp Ile Gln Ile Arg Phe Tyr
 340 345 350
 Glu Glu Glu Glu Asn Gly Gly Val Trp Glu Gly Phe Gly Asp Phe Ser
 355 360 365
 Pro Thr Asp Val His Arg Gln Phe Ala Ile Val Phe Lys Thr Pro Lys
 370 375 380
 Tyr Lys Asp Ile Asn Ile Thr
 385 390

(2) INFORMATION FOR SEQ ID NO:116:

(i) SEQUENCE CHARACTERISTICS:

- (A) LENGTH: 241 amino acids
- (B) TYPE: amino acid
- (D) TOPOLOGY: linear

(ii) MOLECULE TYPE: protein

(iii) HYPOTHETICAL: NO

(iv) ANTI-SENSE: NO

(v) FRAGMENT TYPE: N-terminal

(xi) SEQUENCE DESCRIPTION: SEQ ID NO:116:

Met Arg Gln Arg Ile Thr Leu Lys Asp Tyr Ala Met Arg Phe Gly Gln
 1 5 10 15
 Thr Lys Thr Ala Lys Asp Leu Gly Val Tyr Gln Ser Ala Ile Asn Lys
 20 25 30
 Ala Ile His Ala Gly Arg Lys Ile Phe Leu Thr Ile Asn Ala Asp Gly
 35 40 45
 Ser Val Tyr Ala Glu Glu Val Lys Pro Phe Pro Ser Asn Lys Lys Thr
 50 55 60
 Thr Ala Ser Asn Lys Lys Thr Thr Ala Gly Asp Pro Gly Lys Lys Lys
 65 70 75 80
 Gln His Ile Cys His Ile Gln Gly Cys Gly Lys Val Tyr Gly Lys Thr
 85 90 95

128

Ser His Leu Arg Ala His Leu Arg Trp His Thr Gly Glu Arg Pro Phe
100 105 110

Met Cys Thr Trp Ser Tyr Cys Gly Lys Arg Phe Thr Arg Ser Asp Glu
115 120 125

Leu Gln Arg His Lys Arg Thr His Thr Gly Glu Lys Lys Phe Ala Cys
130 135 140

Pro Glu Cys Pro Lys Arg Phe Met Arg Ser Asp His Leu Ser Lys His
145 150 155 160

Ile Lys Thr His Gln Asn Lys Lys Gly Gly Pro Gly Val Ala Leu Ser
165 170 175

Val Gly Thr Leu Pro Leu Asp Ser Gly Ala Gly Ser Glu Gly Ser Gly
180 185 190

Thr Ala Thr Pro Ser Ala Leu Ile Thr Thr Asn Met Val Ala Met Glu
195 200 205

Ala Ile Cys Pro Glu Gly Ile Ala Arg Leu Ala Asn Ser Gly Ile Asn
210 215 220

Val Met Gln Val Ala Asp Leu Gln Ser Ile Asn Ile Ser Gly Asn Gly
225 230 235 240

Phe

(2) INFORMATION FOR SEQ ID NO:117:

- (i) SEQUENCE CHARACTERISTICS:
 - (A) LENGTH: 10 base pairs
 - (B) TYPE: nucleic acid
 - (C) STRANDEDNESS: both
 - (D) TOPOLOGY: linear
- (ii) MOLECULE TYPE: cdna
- (iii) HYPOTHETICAL: NO
- (iv) ANTI-SENSE: NO
- (xi) SEQUENCE DESCRIPTION: SEQ ID NO:117:

GGGAMTNYCC

10

(2) INFORMATION FOR SEQ ID NO:118:

- (i) SEQUENCE CHARACTERISTICS:
 - (A) LENGTH: 72 amino acids
 - (B) TYPE: amino acid
 - (D) TOPOLOGY: linear

Claims

What is claimed is:

- 1 1. A probe nucleic acid (PNA) comprising:
2 (a) a single-stranded sequence, 1/2 TBR, which is capable of forming, under
3 hybridizing conditions, a hybrid, TBR, with a 1/2 TBR present in a target nucleic
4 acid (TNA);
5 (b) a single stranded sequence, 1/2 BBR, which is capable of forming, under
6 hybridizing conditions, a hybrid BBR, with about 0-10 1/2 BBR present in a
7 booster nucleic acid (BNA); and
8 (c) an OSA, which is no attached support and/or indicator, or an attached support or
9 other means of localization, including, but not limited to, attachment to beads,
10 polymers, and surfaces, and/or indicators;
11 wherein said TBR is capable of binding with high affinity to a TBA, said TBA being a substance
12 capable of discriminating between a paired TBR and a TBR having unpaired nucleotides, and
13 further, wherein said BBR is capable of binding with high affinity to a BBA, said BBA being a
14 substance capable of discriminating between a paired BBR and a BBR having unpaired nucleotides.

- 1 2. A booster nucleic acid (BNA) comprising:
2 (a) a 1/2 BBR which has a sequence which is complementary to a 1/2 BBR sequence
3 in a PNA or another BNA and which is capable of forming, under hybridizing
4 conditions, a hybrid, BBR, with the PNA;
5 (b) an OSA, which is no attached support or indicator or an attached support or other
6 means of localization, including, but not limited to, attachment to beads, polymers,
7 and surfaces, and/or indicators; and
8 (c) additional hybridization sites, 1/2 BBRs, for hybridization with additional BNAs;
9 wherein said BBR is capable of binding with high affinity to a BBA, said BBA being a substance
10 capable of discriminating between a paired BBR and a BBR having unpaired nucleotides.

- 1 3. A Hairpin Nucleic Acid (HNA) comprising a single-stranded sequence, 1/2 BBR, which
2 under hybridizing conditions is capable of forming a hairpin while at the same time binding to a
3 BNA to form a BBR capable of binding a BBA, wherein said BBR is capable of binding with high
4 affinity to a BBA, said BBA being a substance capable of discriminating between a perfect BBR and
5 a BBR having unpaired nucleotides.

1 4. The PNA of claim 1 wherein the TBR is comprised of one or more recognition sites for
2 a nucleic acid binding protein, a DNA binding protein, a DNA-RNA hybrid binding protein or an
3 RNA binding protein.

1 5. The PNA of claim 4 wherein the TBR is a nucleic acid binding protein recognition site
2 present in the genome of a pathogen or is a binding site associated with a pathogenic condition in
3 a vertebrate genome or is a nucleic acid binding protein recognition site present in the genome of an
4 organism which contaminates a fermentation process.

1 6. The PNA of claim 4 wherein the TBR is the HIV-LTR or a portion thereof.

1 7. A method for detecting or localizing a specific TNA sequence, comprising the steps of:
2 (a) hybridizing said TNA with the PNA of claim 1;
3 (b) hybridizing said PNA with a BNA containing a 1/2 BBR whose sequence is
4 complementary to a 1/2 BBR sequence in the PNA;
5 (c) adding the products of steps (a) and (b) containing a TBR and a BBR, to a surface,
6 liquid or other medium containing a TBA;
7 (d) adding BBAs to the mixture in step (c) wherein said BBA comprises:
8 (i) a molecule or a portion of a molecule which is capable of selectively
9 binding to a BBR;
10 (ii) a detectible indicator; and
11 (e) detecting signal produced by the indicator attached to the BBA.

1 8. The method of claim 7 wherein said indicator is a protein, including enzymes capable of
2 catalyzing reactions leading to production of colored reaction products; a radionuclide; colored
3 beads.

1 9. A method for detecting the presence in a sample of a specific Target Nucleic Acid, TNA,
2 which comprises:
3 (a) contacting said sample with a Probe Nucleic Acid, PNA, which, upon hybridization
4 with said TNA if present in said sample, forms a Target Binding Region, TBR,
5 which is capable of binding a Target Binding Assembly, TBA; and

- 6 (b) contacting said sample, already in contact with said PNA, with a TBA capable of
7 binding to any TBRs formed by the hybridization of said PNA and said TNA in the
8 sample.

1 10. A method for detecting or localizing specific nucleic acid sequences with a high degree
2 of sensitivity and specificity which comprises:

- 3 (a) adding PNAs containing a 1/2 BBR and a 1/2 TBR to a sample containing or
4 suspected of containing TNAs containing 1/2 TBR sequences, to form a complex
5 having target binding regions, TBRs, formed by the hybridization of
6 complementary 1/2 TBRs present in the PNAs and TNAs respectively;
- 7 (b) binding the TBRs formed in step (a) to an immobilized TBA to form a TBA-TNA-
8 PNA complex;
- 9 (c) adding Booster Nucleic Acids, BNAs, containing booster binding regions, 1/2
10 BBRs, to the complex formed in step (b) such that the 1/2 BBRs in the BNAs
11 hybridize with the 1/2 BBR sequences present in the PNAs or to 1/2 BBRs present
12 in BNAs already bound to the PNA, to form BBRs, such that TBA-TNA-PNA-
13 (BNA)_n complexes are formed;
- 14 (d) adding Hairpin Nucleic Acids, HNAs, containing 1/2 BBR sequences, to the
15 complex formed in step (c) such that the 1/2 BBRs in the HNAs hybridize with any
16 available 1/2 BBR sequences present in the BNAs of the complex of step (c),
17 thereby capping the extension of the BNAs onto the TBA-TNA-PNA-(BNA)_n
18 complexes of step (c) to form TBA-TNA-PNA-(BNA)_n-HNA complexes;
- 19 (e) adding Booster Binding Assemblies, BBAs, linked to indicator moieties, to the
20 TBA-TNA-PNA-(BNA)_n-HNA complexes formed in step (d) to form TBA-TNA-
21 PNA-(BNA-BBA)_n-HNA complexes; and
- 22 (f) detecting the signals produced by the indicator moieties linked to the TBAs, PNAs,
23 BNAs, BBAs or HNAs in the TBA-TNA-PNA-(BNA-BBA)_n-HNA complexes of
24 step (e);

25 wherein the TNA comprises:

- 26 (i) one or more specific 1/2 TBR nucleic acid sequences, the presence or
27 absence of which in a particular sample is to be confirmed;

28 the PNA comprises:

- 29 (i) a single-stranded sequence, 1/2 TBR, which is capable of forming, under
30 hybridizing conditions, a hybrid, TBR, with a 1/2 TBR present in a target
31 nucleic acid (TNA);
- 32 (ii) a single stranded sequence, 1/2 BBR, which is capable of forming, under
33 hybridizing conditions, a hybrid BBR with a 1/2 BBR present in a booster
34 nucleic acid (BNA); and
- 35 (iii) an OSA, which is no attached support and/or indicator, or an attached
36 support or other means of localization, including, but not limited to,
37 attachment to beads, polymers, and surfaces, and/or indicators;

38 the BNA comprises:

- 39 (i) a 1/2 BBR, as shown in Figure 1(IIb), which has a sequence which is
40 complementary to a 1/2 BBR sequence in a PNA and which is capable of
41 forming, under hybridizing conditions, a hybrid, BBR, with the PNA;
- 42 (ii) an OSA, which is no attached support or indicator or an attached support
43 or other means of localization, including, but not limited to, attachment to
44 beads, polymers, and surfaces, and/or indicators;
- 45 (iii) additional hybridization sites, 1/2 BBRs, for other BNAs; and
- 46 (iv) sequences, 1/2 BBRs, which can hybridize to BNAs already hybridized to
47 the PNA;

48 the BBA comprises:

- 49 (i) a molecule or a portion of a molecule which is capable of selectively
50 binding to a BBR; and
- 51 (ii) an OSA, which is no attached support and/or indicator, or an attached
52 support or other means of localization, including, but not limited to,
53 attachment to beads, polymers, and surfaces, and/or indicators;

54 and the TBA comprises:

- 55 (i) a molecule or a portion of a molecule which is capable of selectively
56 binding to a TBR; and
- 57 (ii) no attached support and/or indicator, or an attached support or other
58 means of localization, including, but not limited to, attachment to beads,
59 polymers, and surfaces, and/or indicators.

1 11. In a solid phase hybridization method for detecting the presence of a target
2 polynucleotide involving: immobilizing a target polynucleotide, if present in a test sample, directly

3 or via an intermediate capture structure, on a solid phase at a capture site; before, during or after said
4 immobilization, attaching a detectable label to said target polynucleotide, if present; and detecting
5 said label, if any, at said capture site; the improvement comprising:

- 6 (a) using a Target Binding Assembly, TBA, as the means for achieving immobilization
7 of said target polynucleotide, wherein said TBA binds only to a unique hybrid
8 formed between a specific Probe Nucleic Acid, PNA, and said target nucleic acid
9 such that a perfect Target Binding Region, TBR, recognizable by said TBA is
10 formed; and
11 (b) including in the PNA a single stranded sequence, 1/2 BBR, capable of binding a
12 Booster Nucleic Acid, BNA, containing a single stranded complementary 1/2 BBR
13 which, upon hybridization with the 1/2 BBR in the PNA, forms a BBR capable of
14 binding labeled Booster Binding Assemblies, BBAs.

1 12. A target binding assembly, TBA, or a booster binding assembly, BBA, comprising at
2 least one nucleic acid recognition unit, and optionally one or all of the sequences selected from the
3 group consisting of a linker sequence, an assembly sequence, an asymmetry sequence, a nuclear
4 localization signal sequence (NLS) and an OSA.

1 13. The TBA of claim 12 wherein the nucleic acid recognition unit is selected from the
2 group consisting of an NF-kB binding unit, an SP1 binding unit, a TATA binding unit, a human
3 papillomavirus E2 binding unit, an HPV LTR binding unit, an HIV LTR binding unit, and Tat.

1 14. The TBA of claim 13 wherein the nucleic acid recognition unit has the sequence
2 selected from the group consisting of SEQ ID NO. 63, SEQ ID NO. 64, SEQ ID NO. 65, SEQ ID
3 NO. 66, SEQ ID NO. 67, SEQ ID NO. 68, SEQ ID NO. 69, SEQ ID NO. 70, SEQ ID NO. 71, SEQ
4 ID NO. 72, SEQ ID NO. 73, SEQ ID NO. 74, SEQ ID NO. 75, SEQ ID NO. 76, SEQ ID NO. 77,
5 SEQ ID NO. 78, SEQ ID NO. 79, SEQ ID NO. 80, SEQ ID NO. 81, SEQ ID NO. 82, SEQ ID NO.
6 83, SEQ ID NO. 84, SEQ ID NO. 93, SEQ ID NO. 94, SEQ ID NO. 95, SEQ ID NO. 96, SEQ ID
7 NO. 97, SEQ ID NO. 98, and SEQ ID NO. 118.

1 15. The TBA of claim 12 wherein the linker sequence is an oligopeptide which does not
2 interfere with the nucleic acid recognition function of the nucleic acid recognition unit and which
3 provides stability and control over the spacing of the nucleic acid recognition unit from the remainder
4 of the TBA.

1 16. The TBA of claim 15 wherein the linker sequence is an oligopeptide sequence from the
2 interdomain primary sequence of a structural protein.

1 17. The TBA of claim 12 wherein the assembly sequence is an oligopeptide sequence which
2 directs the folding and association of nucleic acid recognition units.

1 18. The TBA of claim 17 wherein the assembly sequence is derived from the bacteriophage
2 lambda *cro* protein or the CI protein and is selected from the group consisting of SEQ ID NO. 104,
3 SEQ ID NO. 105, SEQ ID NO. 106, SEQ ID NO. 107, and SEQ ID NO. 108.

1 19. The TBA of claim 12 wherein the asymmetry sequence directs the association of nucleic
2 acid recognition and assembly sequences in a predetermined order.

1 20. The TBA of claim 19 wherein the asymmetry sequence is derived from insulin,
2 gonadotropic hormone, FSH, HCG, LH, ACTH, or relaxin.

1 21. The TBA of claim 20 wherein the asymmetry sequence is selected from the group
2 consisting of SEQ ID NO. 85, SEQ ID NO. 86, SEQ ID NO. 87, SEQ ID NO. 88, SEQ ID NO. 89,
3 SEQ ID NO. 90, SEQ ID NO. 91, and SEQ ID NO. 92.

1 22. The TBA of claim 12 wherein the NLS is an oligopeptide which directs the migration
2 and uptake of a protein or complex associated with said NLS into the nucleus of a cell.

1 23. The TBA of claim 22 wherein the NLS is selected from the group consisting of SEQ
2 ID NO. 72 and SEQ ID NO. 103.

1 24. The TBA of claim 12 which is HIV Detect I-IV or HPV Detect I-IV.

1 25. The TBA of claim 12 having a sequence selected from the group consisting of SEQ ID
2 NO. 109, SEQ ID NO. 110, SEQ ID NO. 111, SEQ ID NO. 112, SEQ ID NO. 113, SEQ ID NO.
3 114, SEQ ID NO. 115, and SEQ ID NO. 116.

1 26. A method of using the TBA of claim 12 to bind a particular nucleic acid sequence in
2 a target nucleic acid sample which comprises:

- 3 (a) fragmenting the nucleic acid in the target nucleic acid sample;
4 (b) contacting, under hybridizing conditions, the fragmented nucleic acid with a probe
5 nucleic acid complementary to the particular nucleic acid sequence of interest,
6 wherein said probe nucleic acid, upon hybridization with said particular nucleic
7 acid sequence of interest forms a target binding region to which said TBA
8 specifically binds.

1 27. The method of claim 26 wherein said probe nucleic acid, in addition to sequences
2 complementary to said particular nucleic acid sequence of interest, also has additional sequences to
3 which a booster nucleic acid can bind to form a booster binding site to which a labeled booster
4 binding assembly can bind to provide a signal showing and amplifying the binding of the probe
5 nucleic acid to the target nucleic acid sequence of interest.

1 28. A method of using the TBA of claim 12 wherein said TBA is administered to patient
2 in need of such treatment a therapeutically or prophylactically effective amount of said TBA, which
3 comprises administering the TBA, either in the form of a purified protein complex or in the form of
4 a recombinant vector which, upon entry into the patient is able to express the TBA, such that the
5 TBA binds the particular nucleic acid sequence to achieve the desired prophylactic or therapeutic
6 result.

1 29. The method of claim 28 wherein said TBA is selected from the group consisting of SEQ
2 ID NO. 109, SEQ ID NO. 110, SEQ ID NO. 111, SEQ ID NO. 112, SEQ ID NO. 113, SEQ ID NO.
3 114, SEQ ID NO. 115, and SEQ ID NO. 116, and the patient is infected with HIV or HPV.

1 30. The method of claim 26 further comprising the step of:
2 (c) monitoring the shift in mobility of nucleic acids in the target nucleic acid sample
3 as a function of the size such that binding of the TBA to a particular fragment in
4 the sample modifies the mobility of the fragment.

1 31. A diagnostic or forensic test kit for the detection in a sample of nucleic acid having a
2 specific sequence composition, which comprises:

3 (a) a first nucleic acid probe complementary to nucleic acid with specific sequence
4 composition, the presence of which is to be ascertained in a test sample, wherein said first nucleic
5 acid probe and said nucleic acid with specific sequence composition forming, upon hybridization,
6 a binding site for a first nucleic acid binding protein, and wherein said first nucleic acid probe further
7 comprises additional sequence complementary to a second nucleic acid probe;

8 (b) a first nucleic acid binding protein specific for the duplex formed by hybridization of
9 said first nucleic acid probe and said nucleic acid with specific sequence composition;

10 (c) a second nucleic acid probe complementary to said additional sequence in said first
11 nucleic acid probe, wherein, upon hybridization of said first and second nucleic acid probes, a
12 binding site for a second nucleic acid binding protein is formed;

13 (d) a second nucleic acid binding protein which binds specifically to the duplex formed
14 upon hybridization of said first nucleic acid probe and said second nucleic acid probe, wherein said
15 second nucleic acid binding protein is labeled with a detectable label.

1 32. The diagnostic or forensic test kit of claim 31 wherein said first nucleic acid probe is
2 complementary to the HIV LTR, such that upon hybridization of said first nucleic acid probe with
3 an HIV LTR, a binding site is formed for NF-kB or a subunit thereof, SP1, TATA binding protein,
4 HIV-Detect I, II, III, or IV, or HIV-Lock.

1 33. The diagnostic or forensic test kit of claim 32 wherein said first nucleic acid binding
2 protein is NF-kB or a subunit thereof, SP1, TATA binding protein, HIV-Detect I, II, III, or IV, or
3 HIV-Lock .

1 34. The diagnostic or forensic test kit of claim 33 wherein said first nucleic acid probe, in
2 addition to being complementary to the HIV LTR, comprises a sequence encoding the bacteriophage
3 lambda left or right operator and said second nucleic acid probe comprises sequences complementary
4 to said bacteriophage lambda left or right operator sequences in said first nucleic acid probe, such
5 that upon hybridization of said first and second nucleic acid probes, a binding site for the
6 bacteriophage lambda CI repressor protein, the bacteriophage lambda *cro* protein or a derivative or
7 homology thereof, is formed.

1 35. The diagnostic or forensic test kit of claim 34 wherein said second nucleic acid binding
2 protein is the bacteriophage lambda CI repressor protein, the bacteriophage lambda *cro* protein or
3 a derivative or homology thereof.

1 36. A composition comprising HIV-Lock or a recombinant vector encoding HIV-Lock and
2 a pharmaceutically acceptable carrier.

1 37. A method of differentially binding a nucleic acid binding protein to a nucleic acid
2 sequence correlated with a pathogenic condition which comprises:

3 (a) selecting a particular configuration of nucleic acid binding protein sequences
4 present in the nucleic acid sequence correlated with a pathogenic condition as a
5 target sequence for designing a probe nucleic acid which will hybridize to that
6 particular configuration of nucleic acid sequences if present in a test sample, and
7 further, ensuring that a binding site for an available nucleic acid binding protein is
8 formed upon hybridization of said probe nucleic acid and said particular
9 configuration of nucleic acid sequences chosen as a target;

10 (b) selecting a nucleic acid binding protein which specifically binds to the selected
11 particular configuration of nucleic acid binding protein sequences correlated with
12 a pathogenic condition, but which does not bind to sequences not correlated with
13 said pathogenic condition;

14 (c) hybridizing said probe nucleic acid with a test sample suspected of containing said
15 particular configuration of nucleic acid binding protein sequences present in nucleic
16 acid sequences correlated with a pathogenic condition;

17 (d) contacting said nucleic acid binding protein with any hybrids formed in step (b);
18 and

19 (e) detecting any binding of said nucleic acid binding protein with said hybrids.

1 38. The method of claim 37 wherein said particular configuration of nucleic acid binding
2 protein sequences is chosen from a necessary step or control point in the development of a
3 pathogenic condition.

1 39. The method of claim 9 wherein said method is carried out in an automated fashion.

1 40. The method of claim 39 wherein the method is carried out in the Abbott Laboratories
2 IMx machine.

1 41. The method of claim 9 carried out in a microtiter plate.

1 42. A method of amplifying the signal obtained through binding the PNA of claim 1 to a
2 TNA which comprises binding BNAs to the PNA-TNA hybrid and binding labeled BBAs to the
3 BNAs.

1 43. A method of assembling a nucleic acid binding complex which comprises using
2 asymmetry sequences to direct the association or non-association of components of the nucleic acid
3 binding complex.

1 44. A method of assembling a nucleic acid binding complex which comprises using
2 assembly sequences derived from bacteriophage lambda *cro* or CI to assemble associated
3 components of the nucleic acid binding complex.

1 45. A method of using assembly, asymmetry, or piloting sequences to assemble a
2 multimeric protein complex which comprises linking subunits to be incorporated into the multimeric
3 protein complex to said assembly, asymmetry, or piloting sequence, and recovering said multimeric
4 complex.

1 46. A composition comprising SEQ ID NO. 105, SEQ ID NO. 106, or SEQ ID NO. 108.

1 47. A nucleic acid encoding the TBA or BBA of claim 12.

1 48. The TBA of claim 12 or a nucleic acid encoding said TBA, wherein the amino acid
2 sequence of said TBA is selected from the group consisting of set A, set B and set C, wherein said
3 sets are comprised as follows:

4 Set Link Sequences from Groups

5 A I + II + III

6 B IV + V + III

7 C IV + III

8 wherein groups I-V consist of sequences selected from:

9 Group Selected from Sequences

10 I Any of SEQ ID NOS. 85-92

11 II Met Ser, linked to any of SEQ ID NOS. 104-106, each of which is linked to SEQ

12 ID NO. 99

- 13 III SEQ ID NO. 100 linked to any of SEQ ID NOS. 75-84 or 94-98; SEQ ID NO. 101
14 linked to either SEQ ID NO. 74 of SEQ ID NO. 93; or SEQ ID NO. 102 linked to
15 SEQ ID NO. 74 or SEQ ID NO. 93; or any of SEQ ID NOS. 72, 103, 73, or 63-71
16 IV Any of SEQ ID NOS. 104-108
17 V SEQ ID NO. 99.

1 49. A method of assembling multimeric TBAs *in vivo* or *in situ* which comprises
2 introducing component TBAs into a cell utilizing a covalently or non-covalently attached protein or
3 bi-layer vesicle or by introducing nucleic acids encoding component TBAs into a cell, said
4 component TBAs each comprising a DNA recognition unit, assembly sequences, asymmetry
5 sequences, nuclear localization signal sequences, and optional linker sequences, such that upon
6 proximal binding via the DNA recognition unit of each component TBA to nucleic acid sequences
7 encountered in the nucleus or elsewhere in the cell, component expressed TBAs assemble via said
8 assembly and asymmetry sequences into multimeric TBAs.

1 50. A method for identifying nucleic acid binding molecules for preparation of a target
2 binding assembly or a booster binding assembly comprising:
3 a. Obtaining a sample containing the target nucleic acid;
4 b. Fragmenting the sample so as to expose the nucleic acids and to reduce the size
5 complexity of the nucleic acids contained in the sample;
6 c. Contacting a first aliquot of the fragmented nucleic acids with a control buffer
7 medium and contacting a second aliquot of the fragmented nucleic acids with the
8 control buffer medium containing a known profile of nucleic acid binding
9 molecules;
10 d. Analyzing the two aliquots to identify fragments which have altered behavior in the
11 aliquot contacted with the target binding molecules as opposed to the aliquot
12 contacted with the control buffer medium;
13 e. Identifying and isolating fragments which do exhibit altered behavior when
14 contacted with the nucleic acid binding molecule and either sequencing the nucleic
15 acid fragment to determine whether known nucleic acid binding molecule motifs are
16 present, or directly identifying the nucleic acid binding molecule bound to the
17 nucleic acid; and

18 f. synthesizing TBAs comprising the nucleic acid binding molecules which produced
19 the altered behavior using assembly, asymmetry nuclear localization and,
20 optionally, linker sequences.

1 51. A method for identifying specific nucleic acid sequences in a sample
2 comprising:
3 a. Fragmenting the nucleic acids in said sample to expose the nucleic acids and reduce
4 the size complexity of the nucleic acids;
5 b. Contacting a TBA with the sample, said TBA comprising two or more nucleic acid
6 binding components each of which has a relatively weak binding for its nucleic acid
7 recognition unit within the TBR but which in combination provides strong binding
8 for the complete TBR; and
9 c. Eliminating any "cross-talk" produced by binding of the TBA to cousin nucleic
10 acids that contain individual recognition units, which comprises contacting the
11 sample with excess nucleic acid binding components with relatively strong binding
12 affinity for cousin nucleic acids that contain the individual recognition units but
13 relatively weak binding relative to the TBA's affinity for binding to the complete
14 TBR having said two or more nucleic acid binding components.

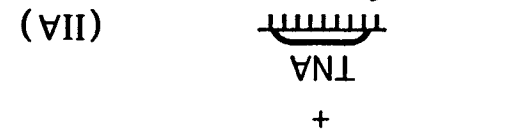
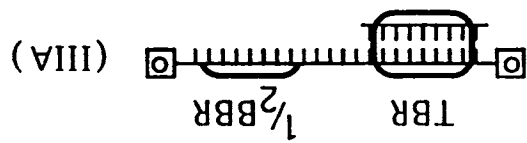
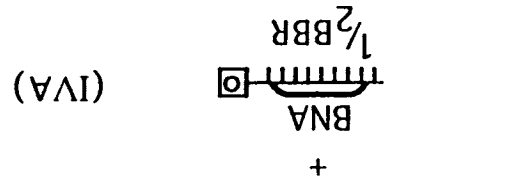
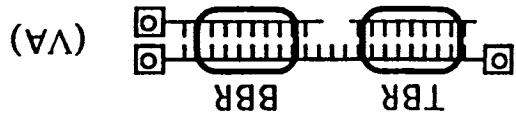
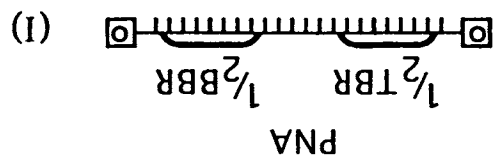
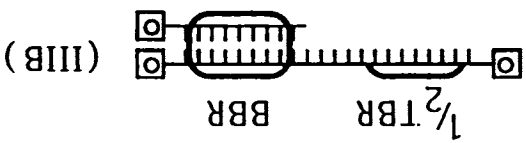
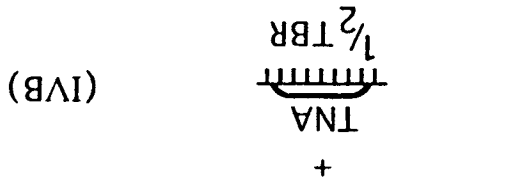
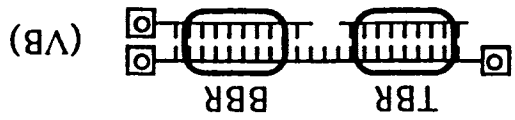
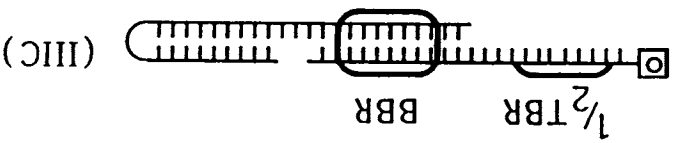
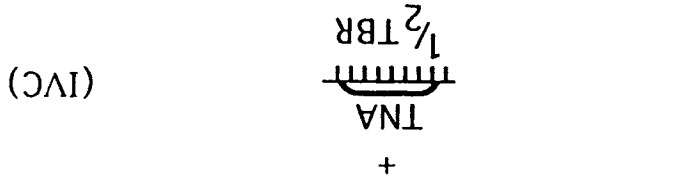
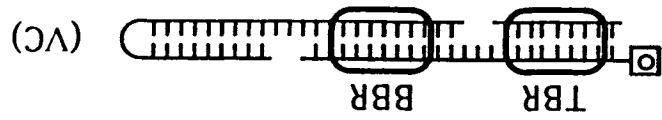
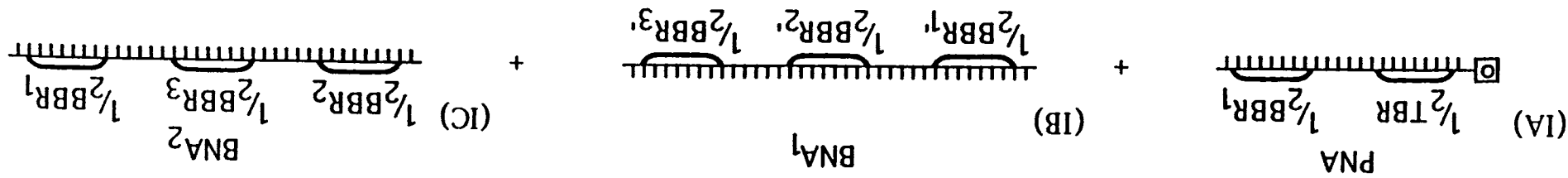

FIGURE 1



⇧

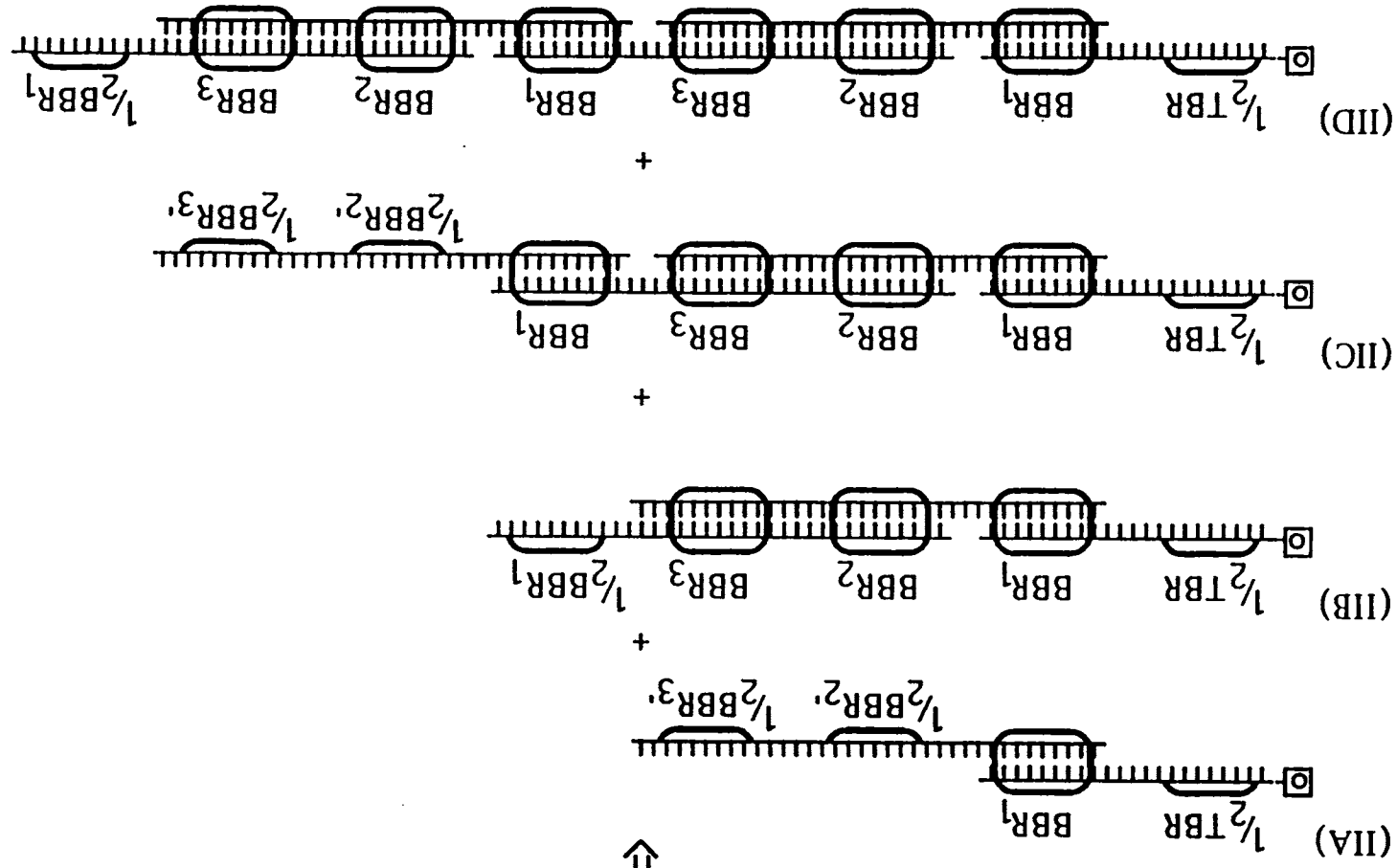

FIGURE 2A

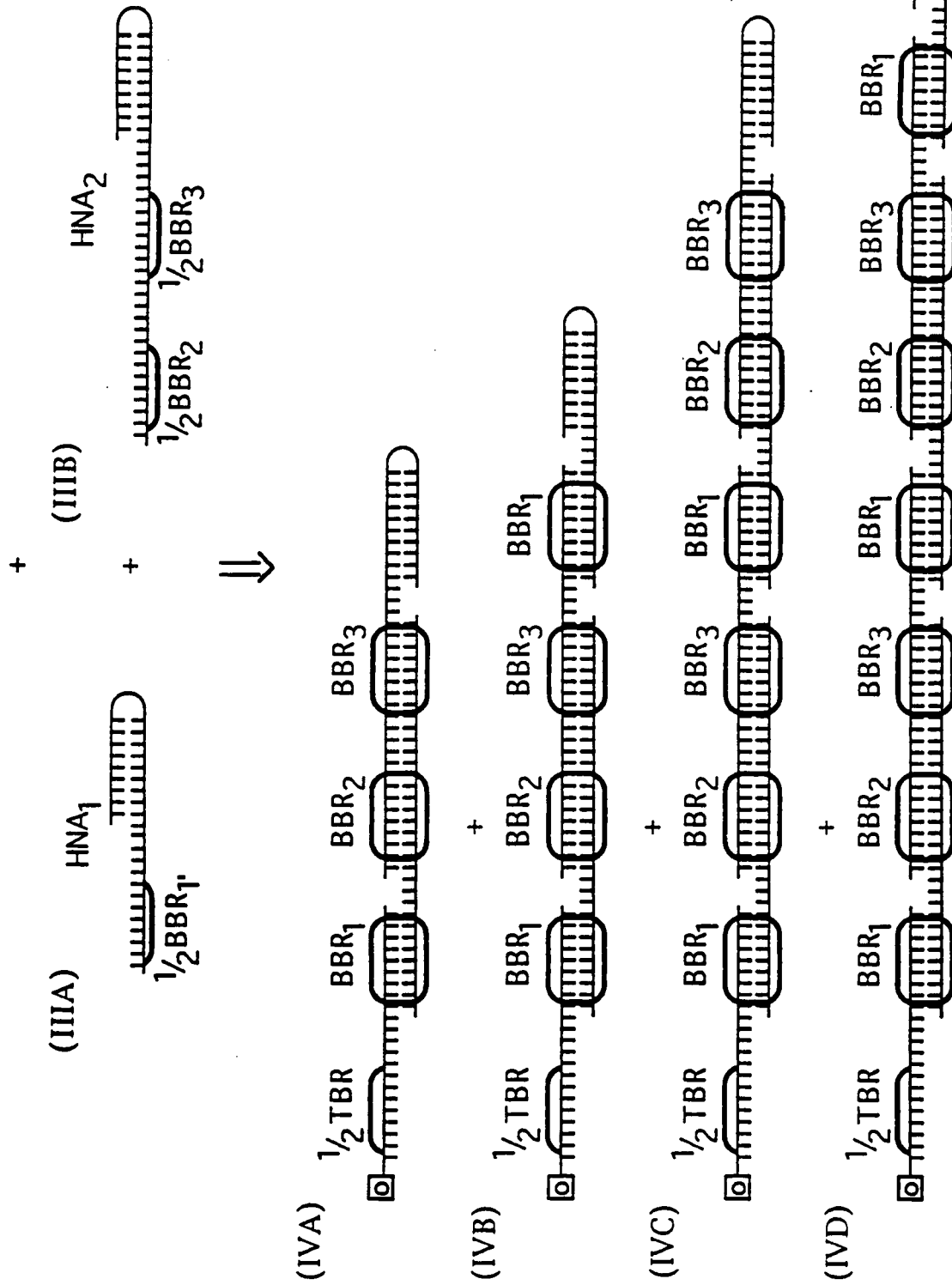

FIGURE 2B

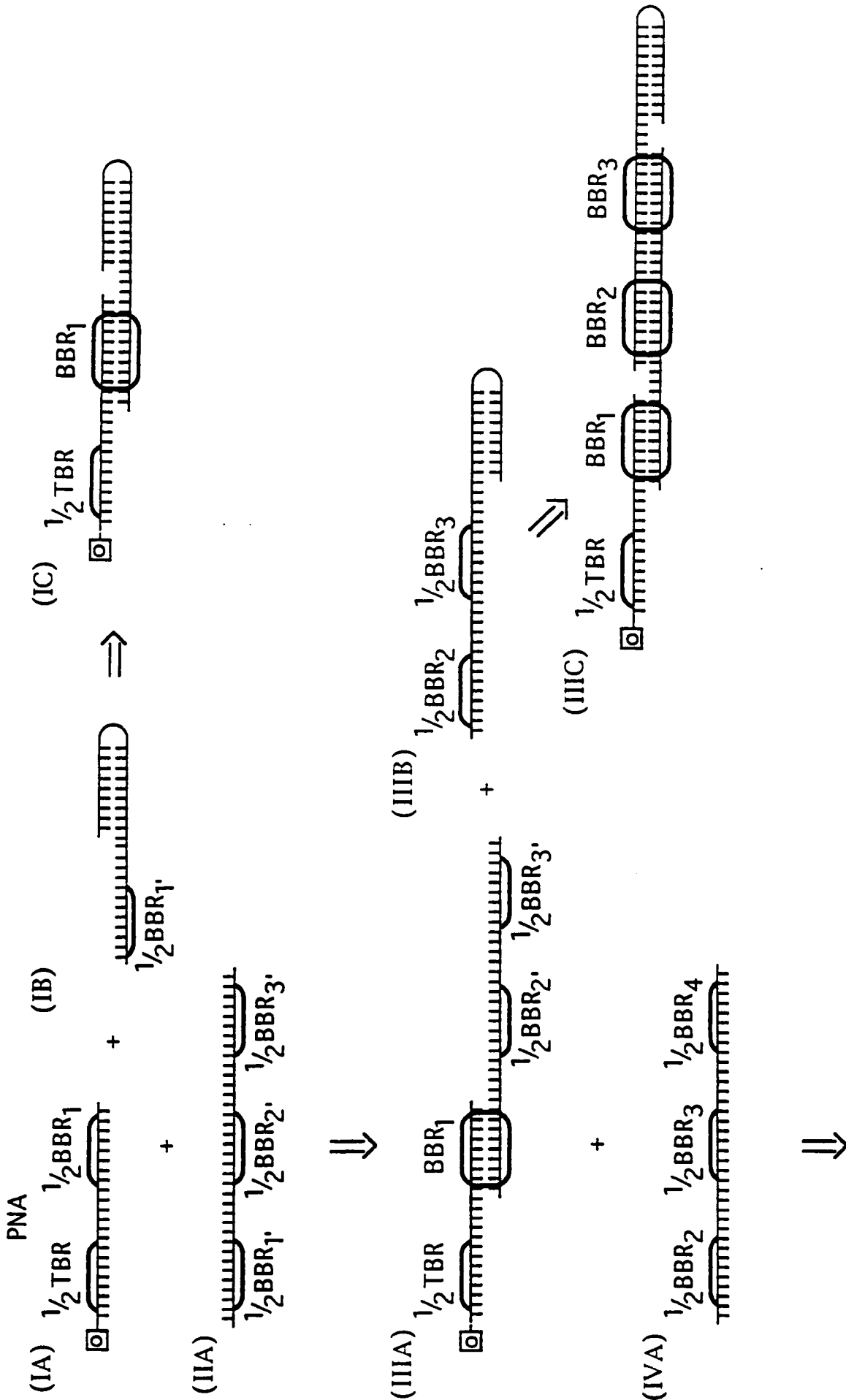

FIGURE 2C

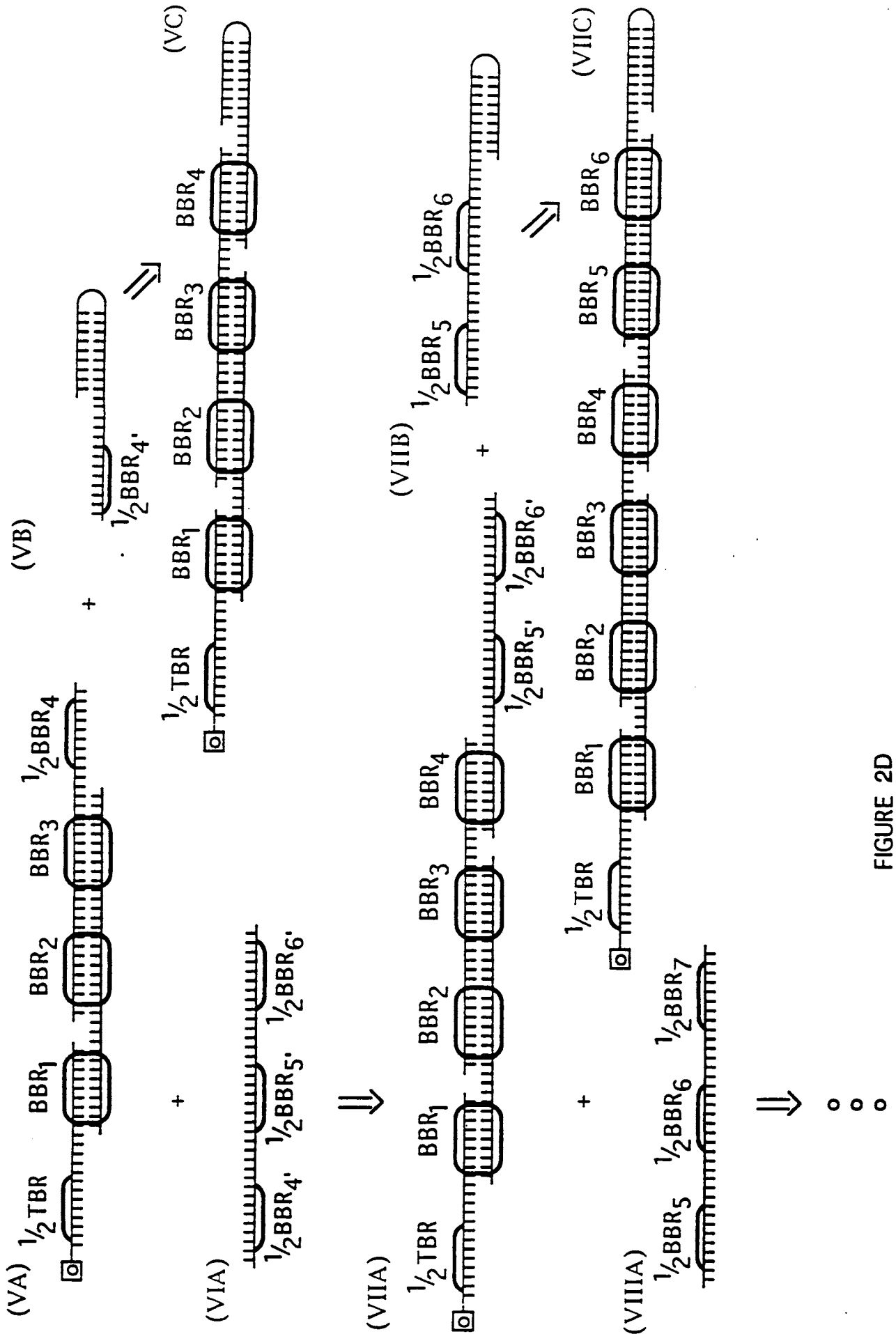

FIGURE 2D

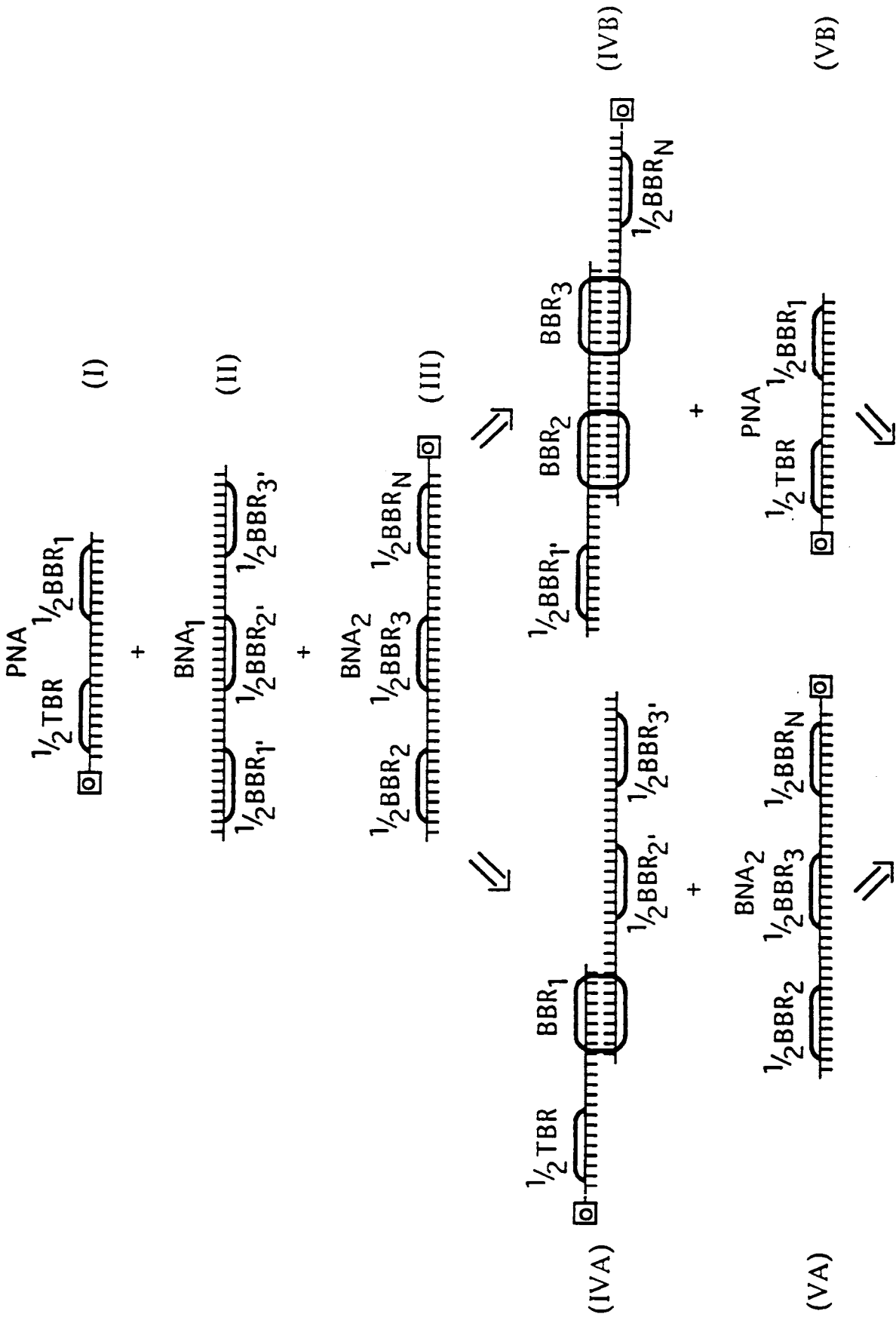

FIGURE 3A

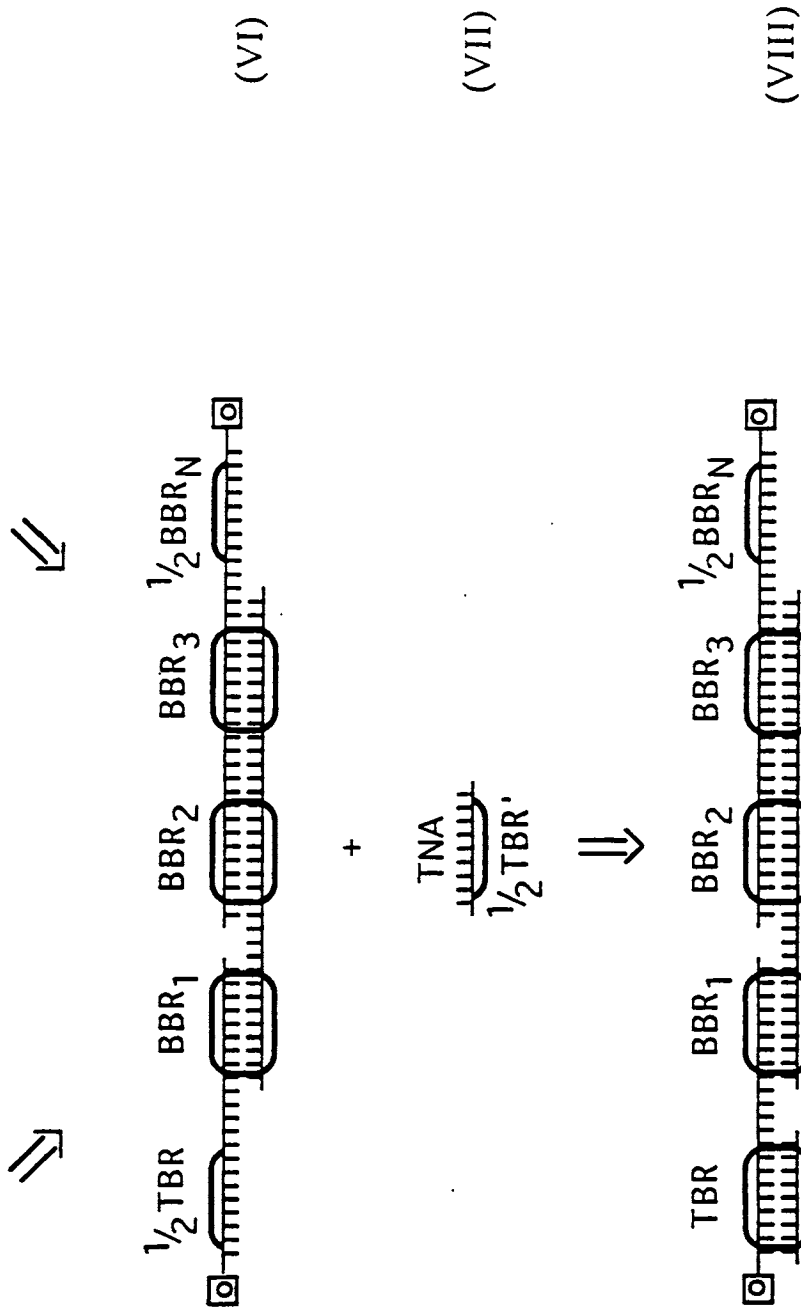

FIGURE 3 B

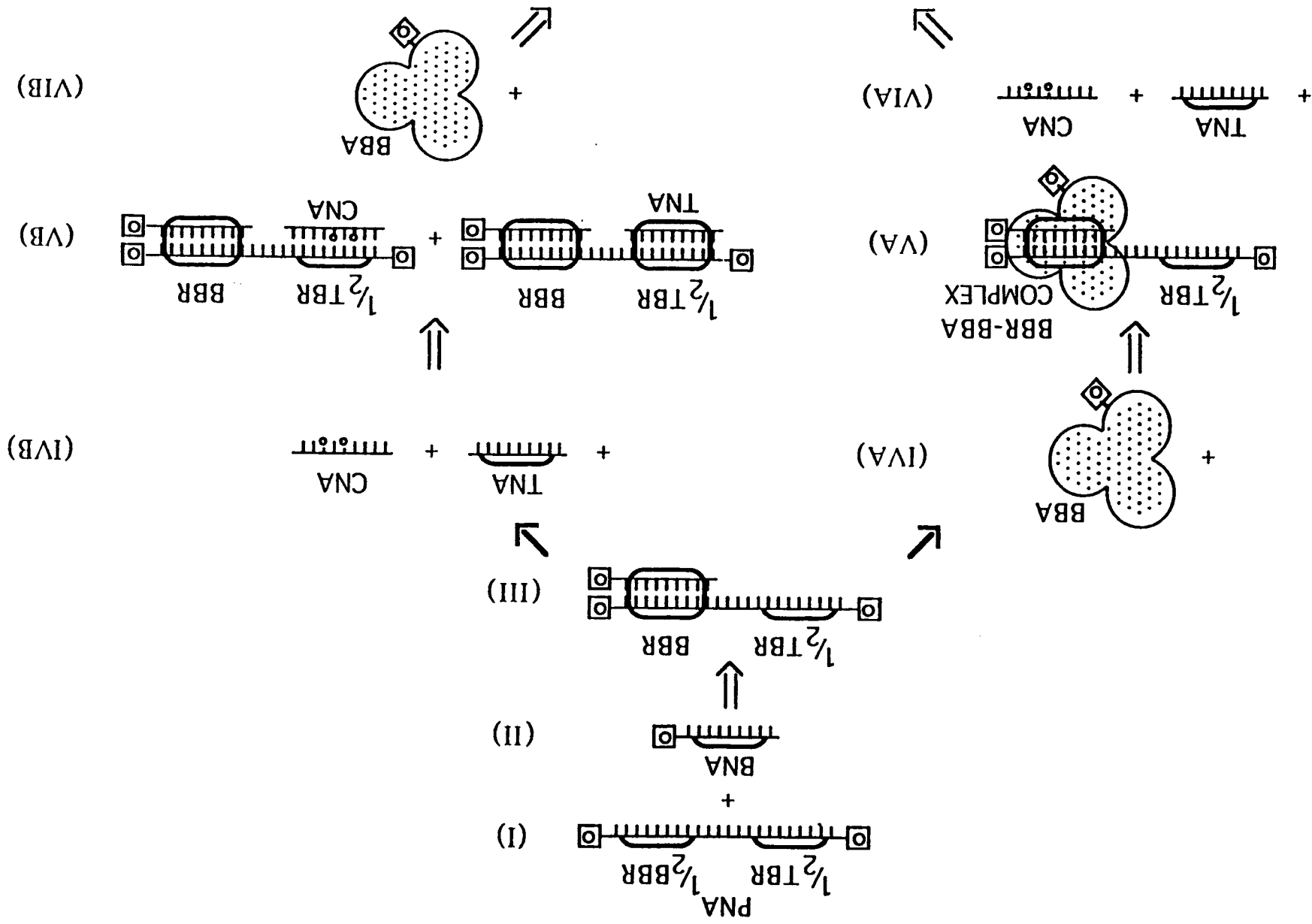

FIGURE 4A

SUBSTITUTE SHEET (RULE 26)

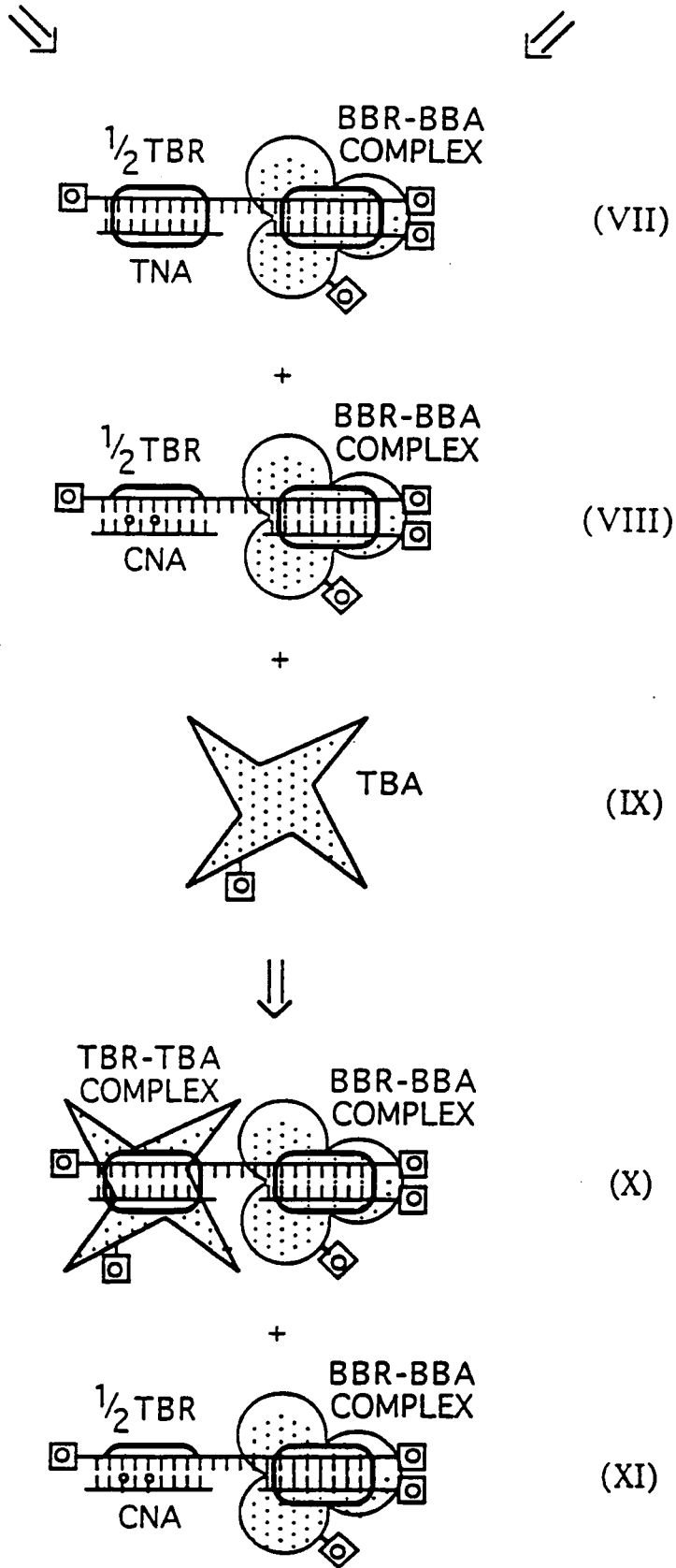

FIGURE 4B

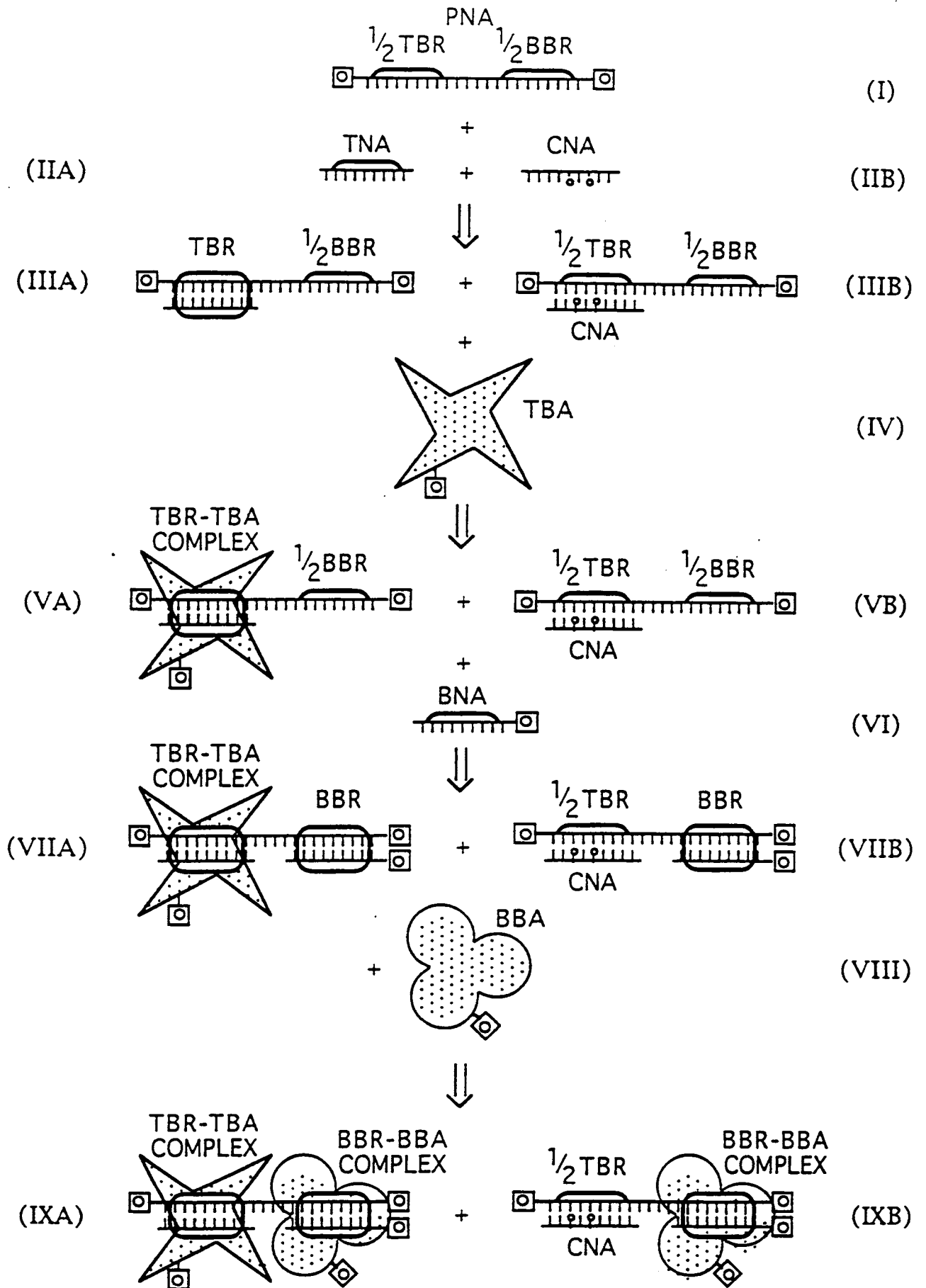

FIGURE 4C

11/29

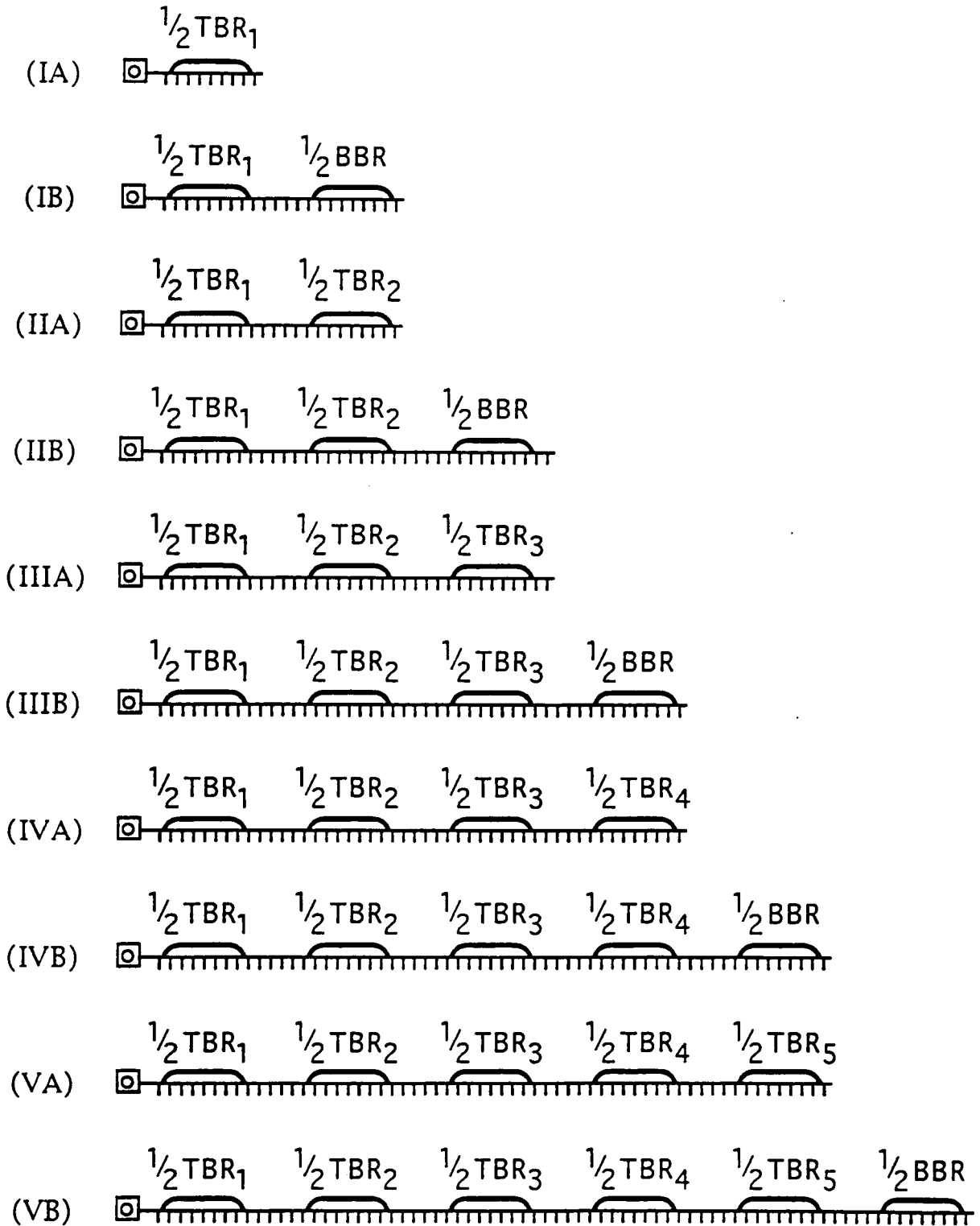

FIGURE 5

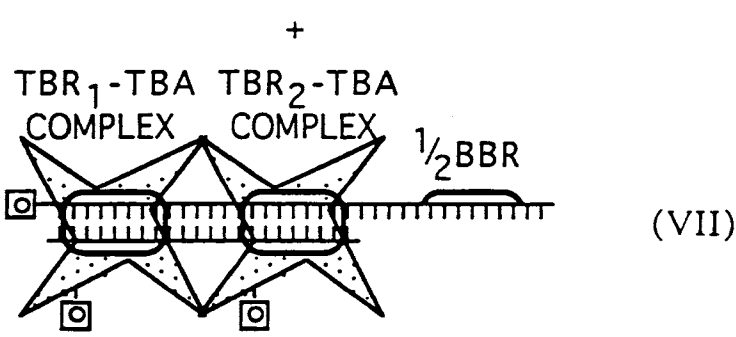
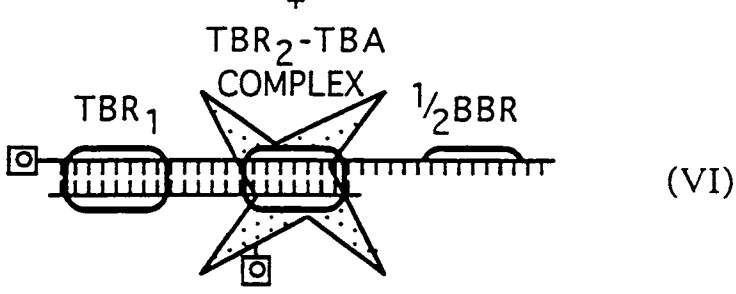
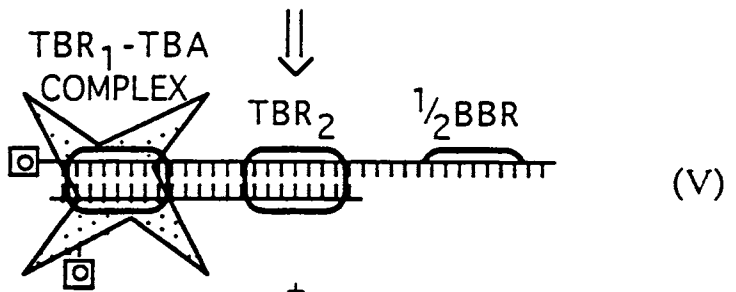
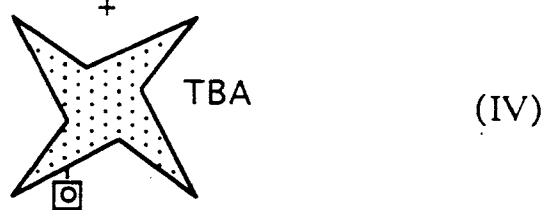
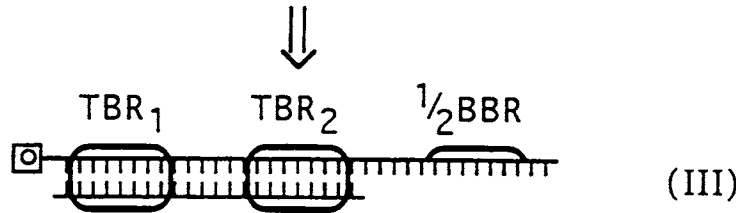
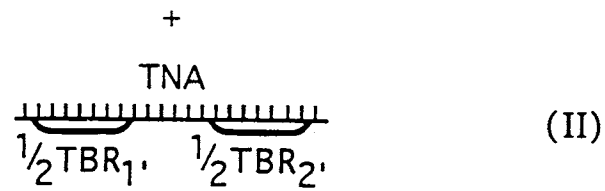
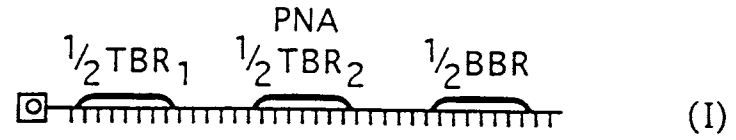

FIGURE 6A

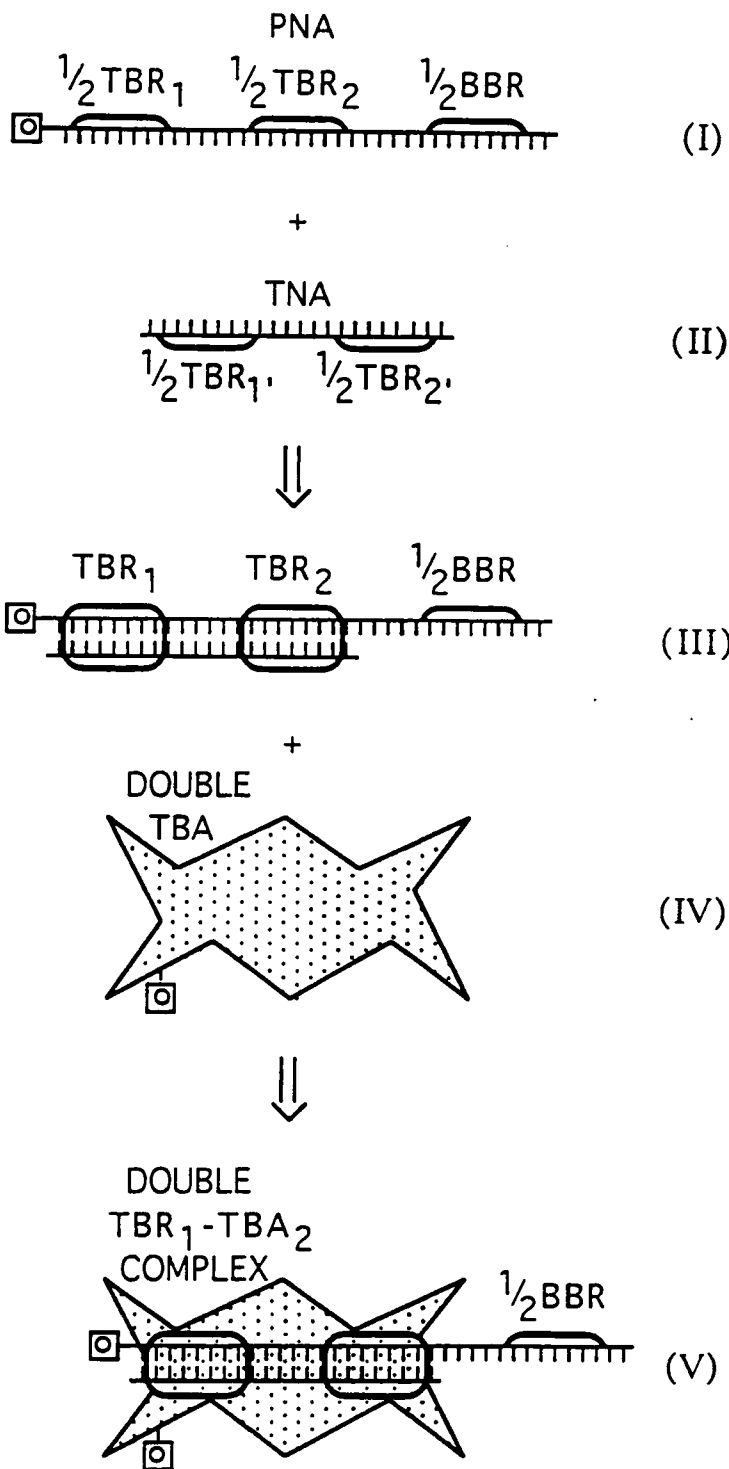

FIGURE 6B

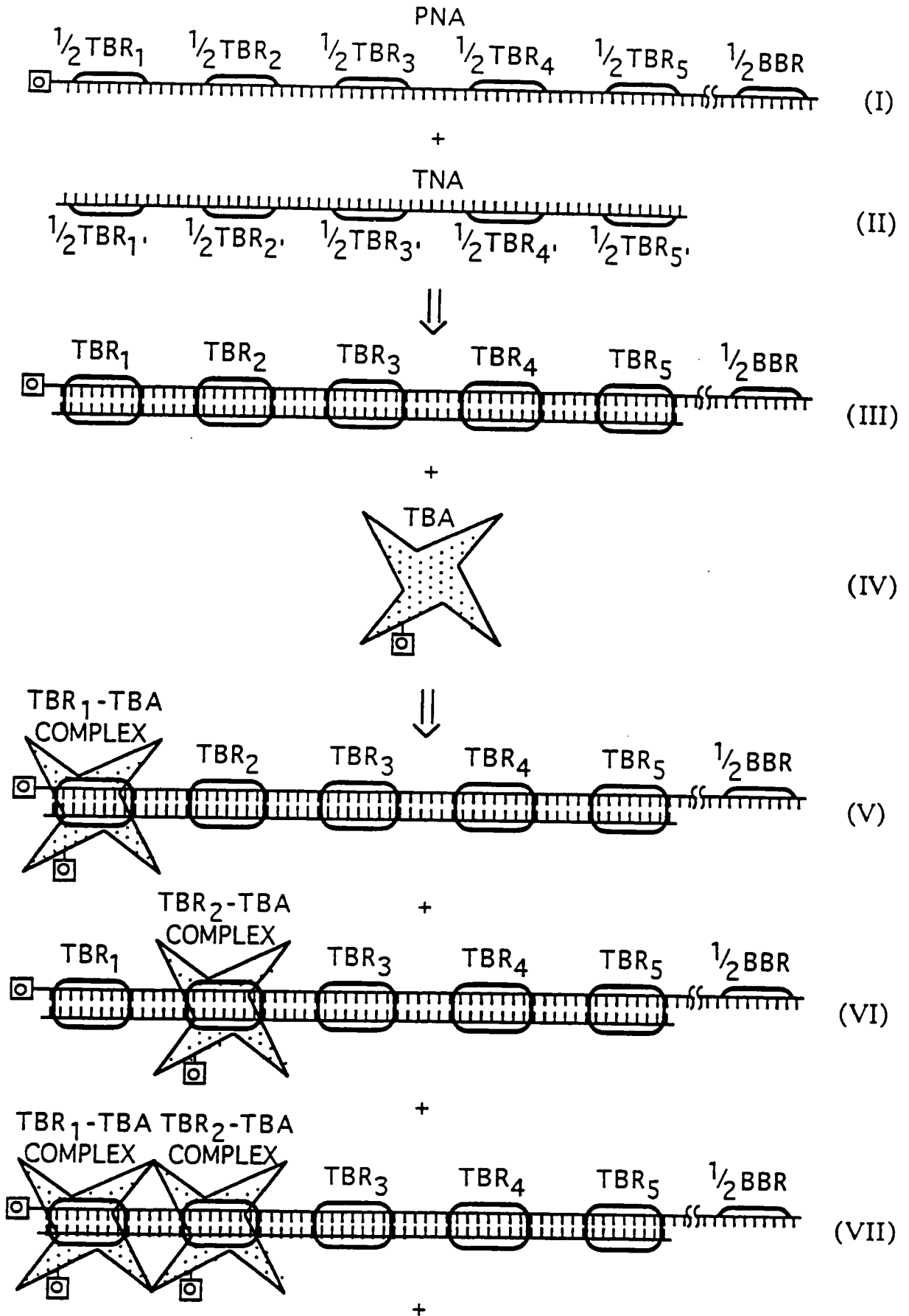

FIGURE 6C

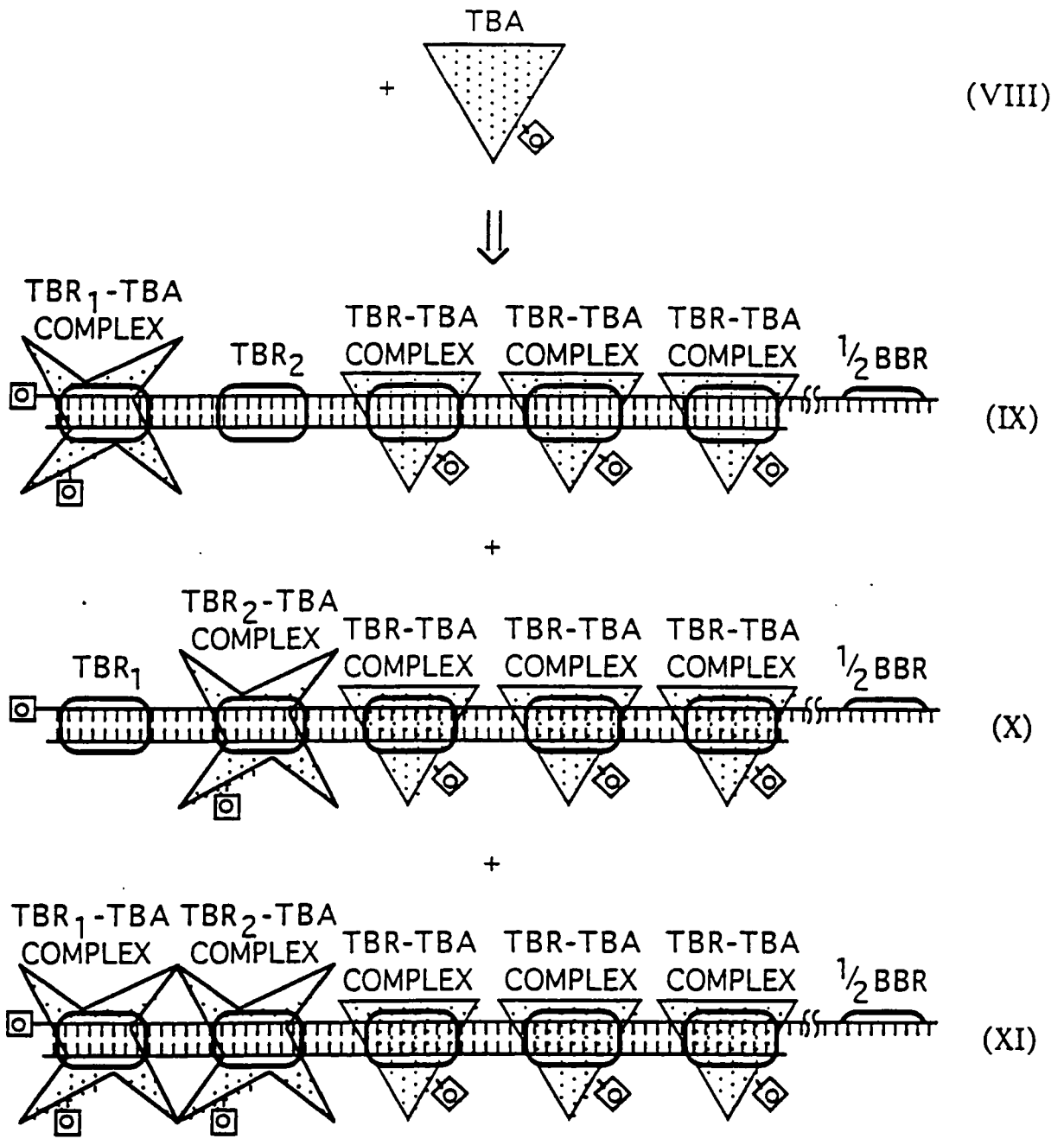

FIGURE 6D

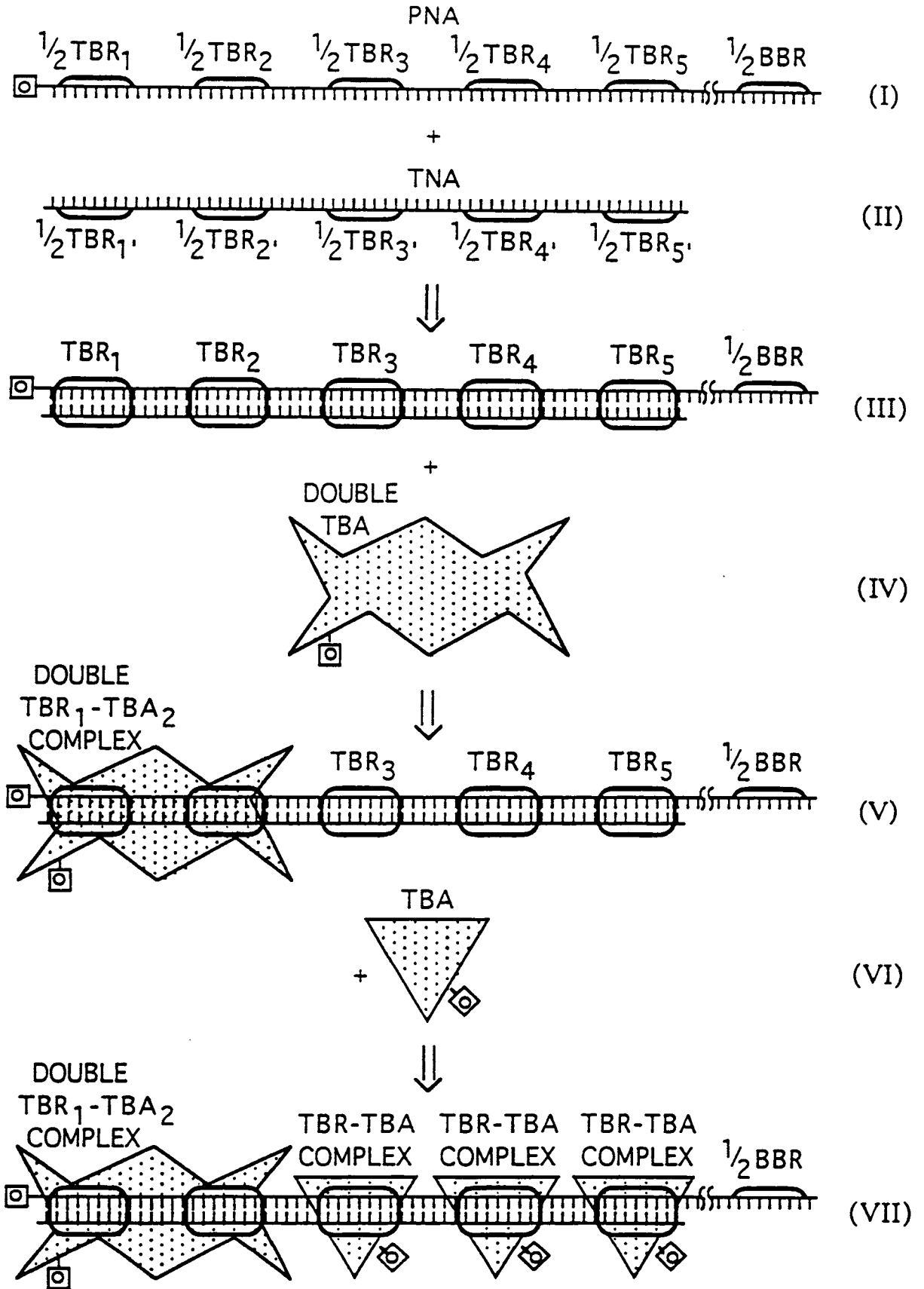

FIGURE 6E

SEQ. ID: 37:

12345678901234567890123456789012345678901234567890
 CTACAAGGGACTTTCCGCTGGGGACTTTCCAGGGAGGCGTGGCCTGGGCGGGACTGGGGAGTGGCGTCCC
 ++++++
 NF-kB NF-kB SP1 SP1 SP1

HIV Test Kit PNA1 (+++ from above), SEQ.ID:38:

CTACAAGGGACTTTCCGCTGGGGACTTTCCAGGGAGG

HIV Test Kit PNA2 (=== from above), SEQ. ID:39:

###CGGGACTGGGGAGTGGCGTCCC###

The sticky end sequence in PNA2 is complimentary to one of the ends of the operator DNA formed from:

###OL1-OL2-OL3
 OL1'-OL2'-OL3'***

or

###OR3-OR2-OR1
 OR3'-OR2'-OR1'***

FIGURE 7

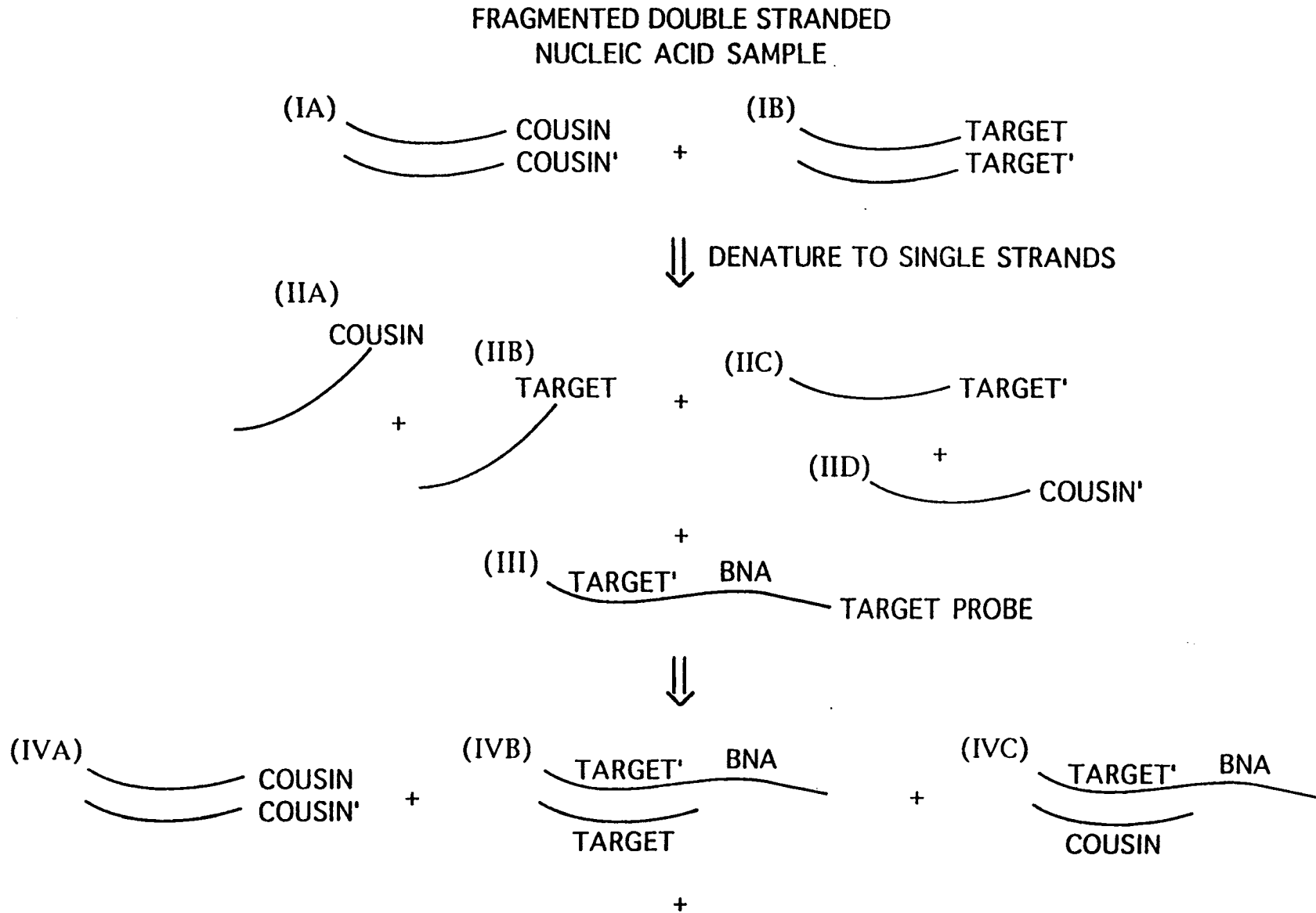

FIGURE 8A

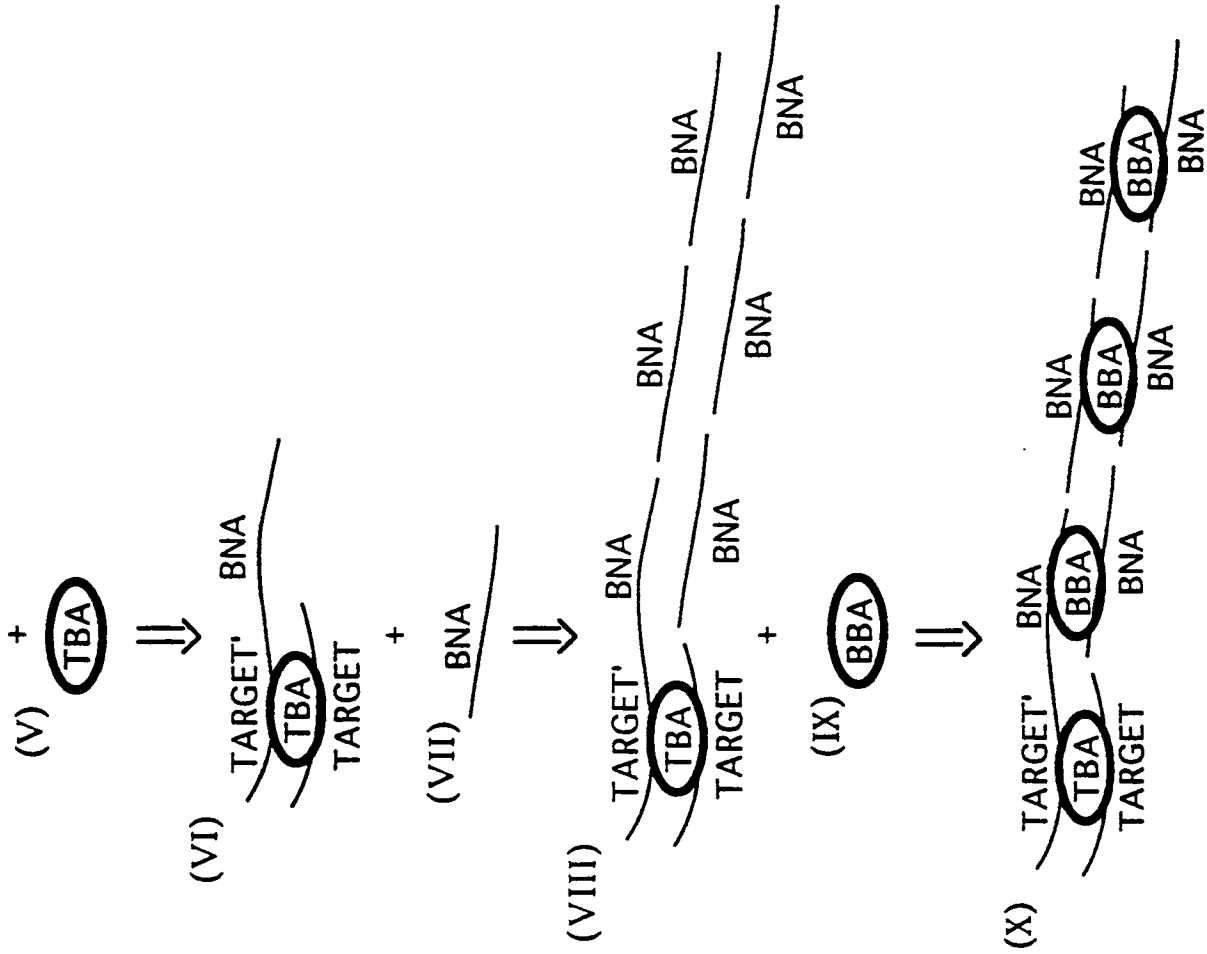

FIGURE 8B

TBA: TARGET BINDING ASSEMBLY

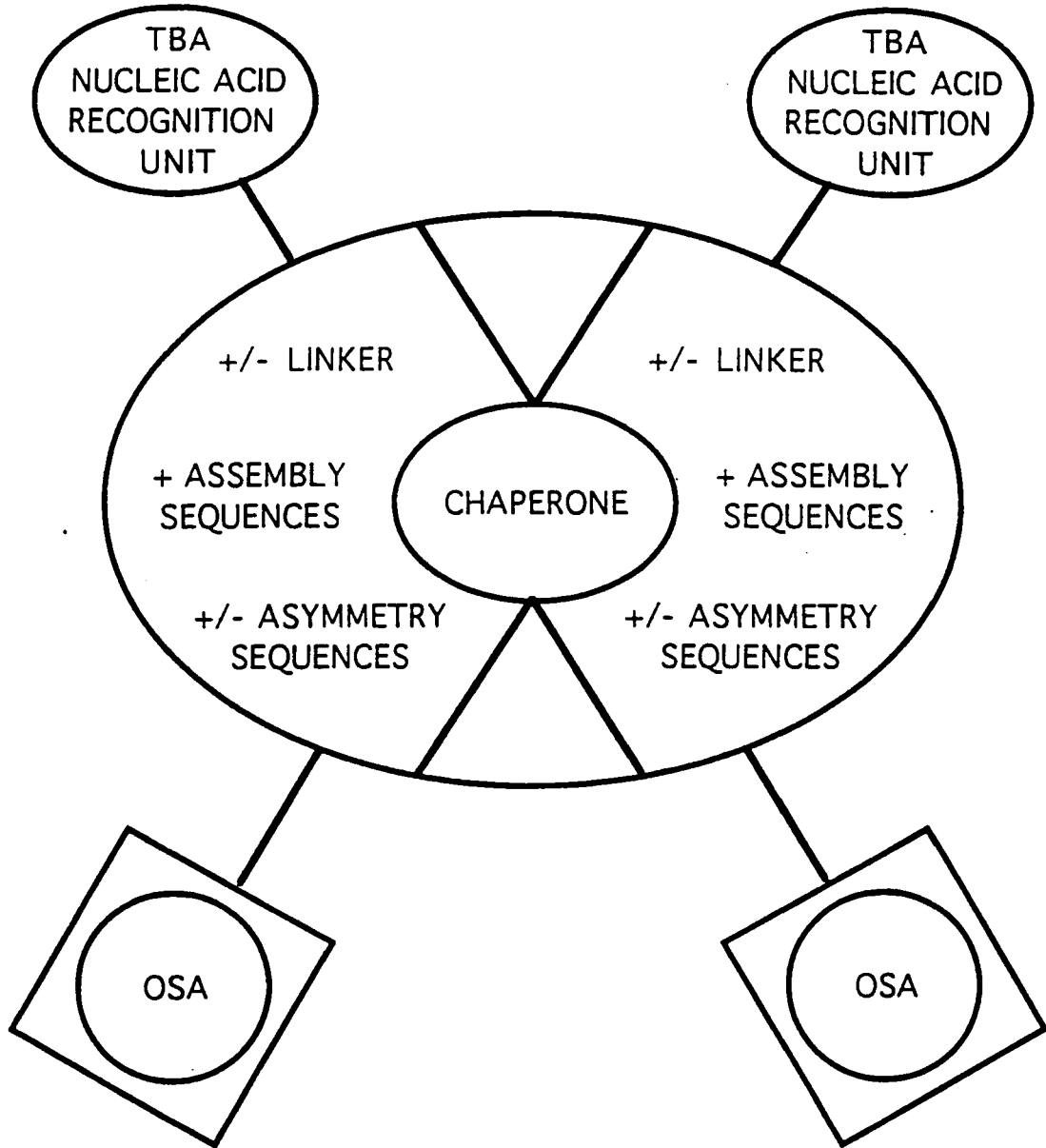
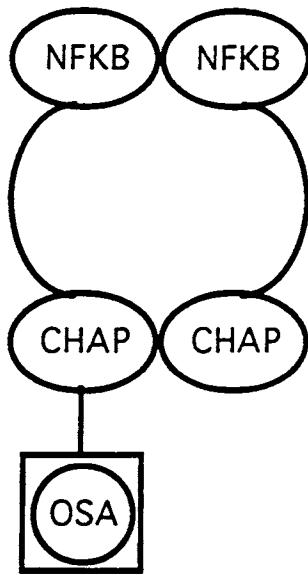
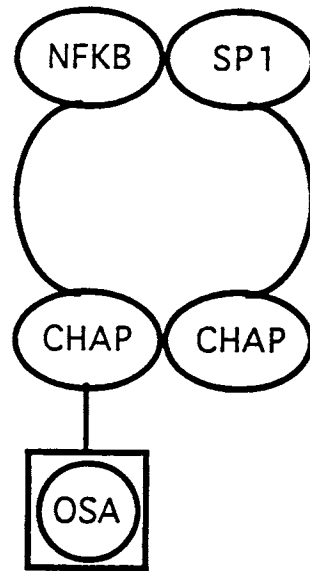

FIGURE 9



HIV-DETECT I



HIV-DETECT II

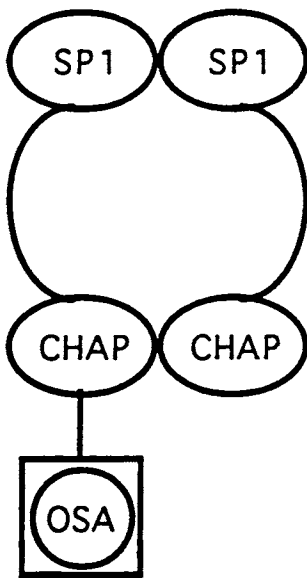

HIV-DETECT III

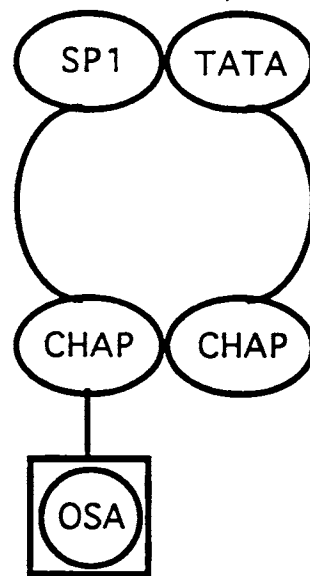

HIV-DETECT IV

FIGURE 10

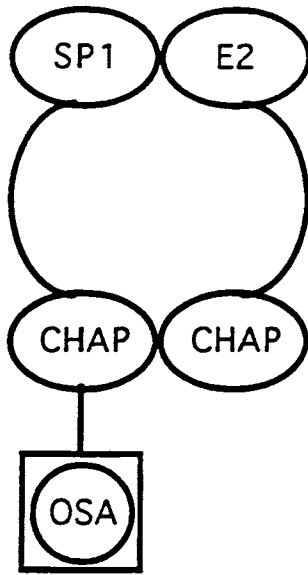

HPV-DETECT I

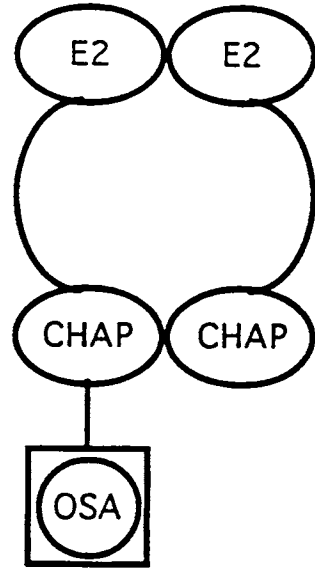

HPV-DETECT II

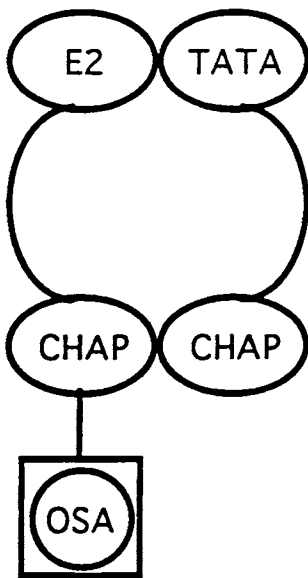

HPV-DETECT III

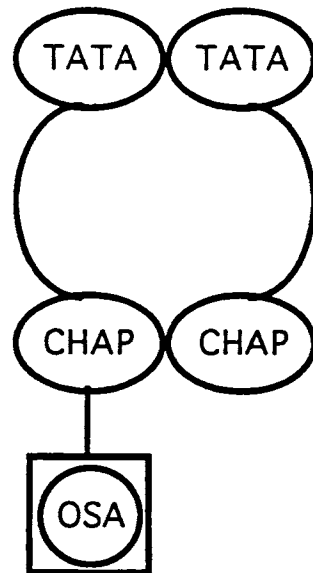

HPV-DETECT IV

FIGURE 11

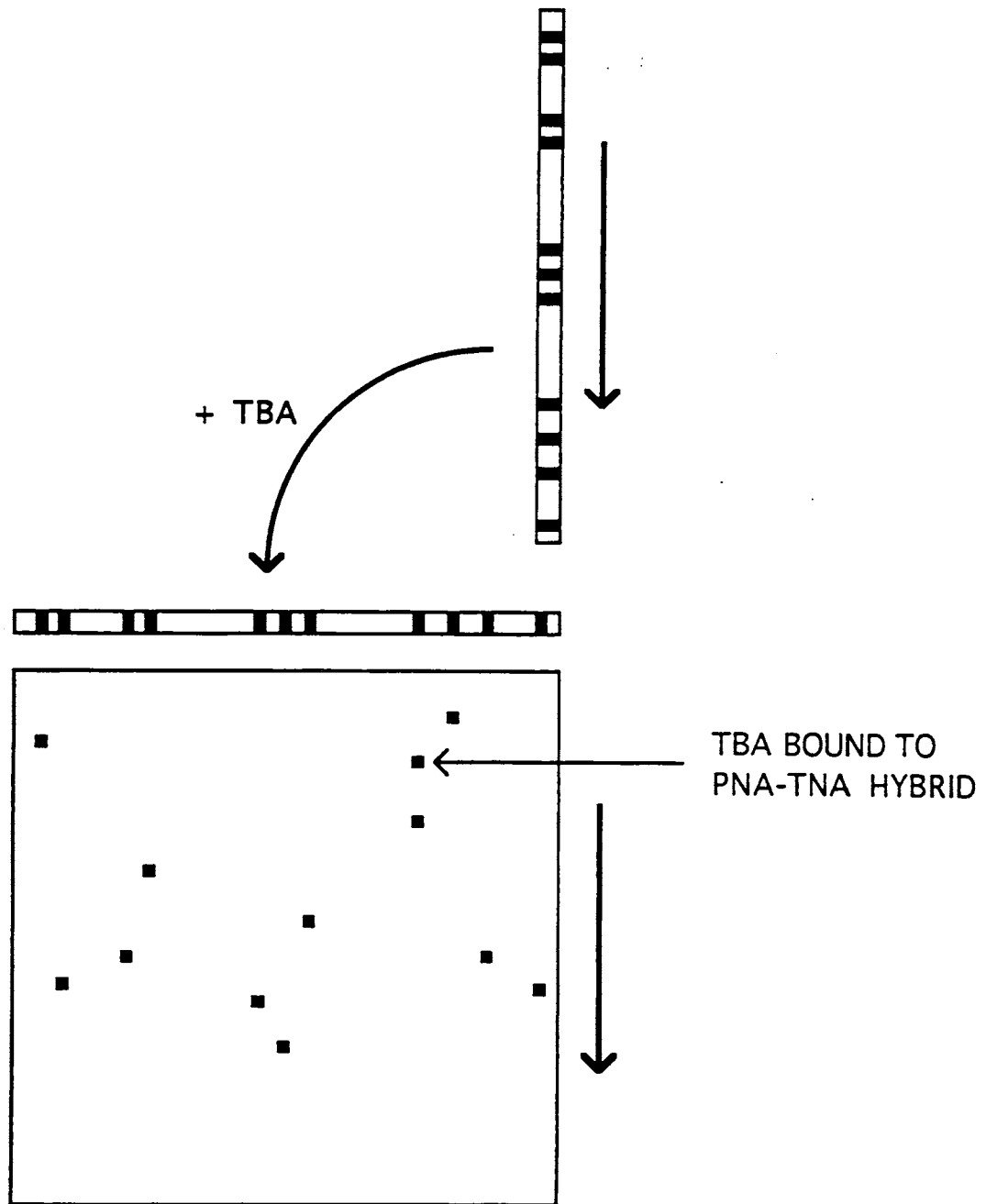

FIGURE 12A

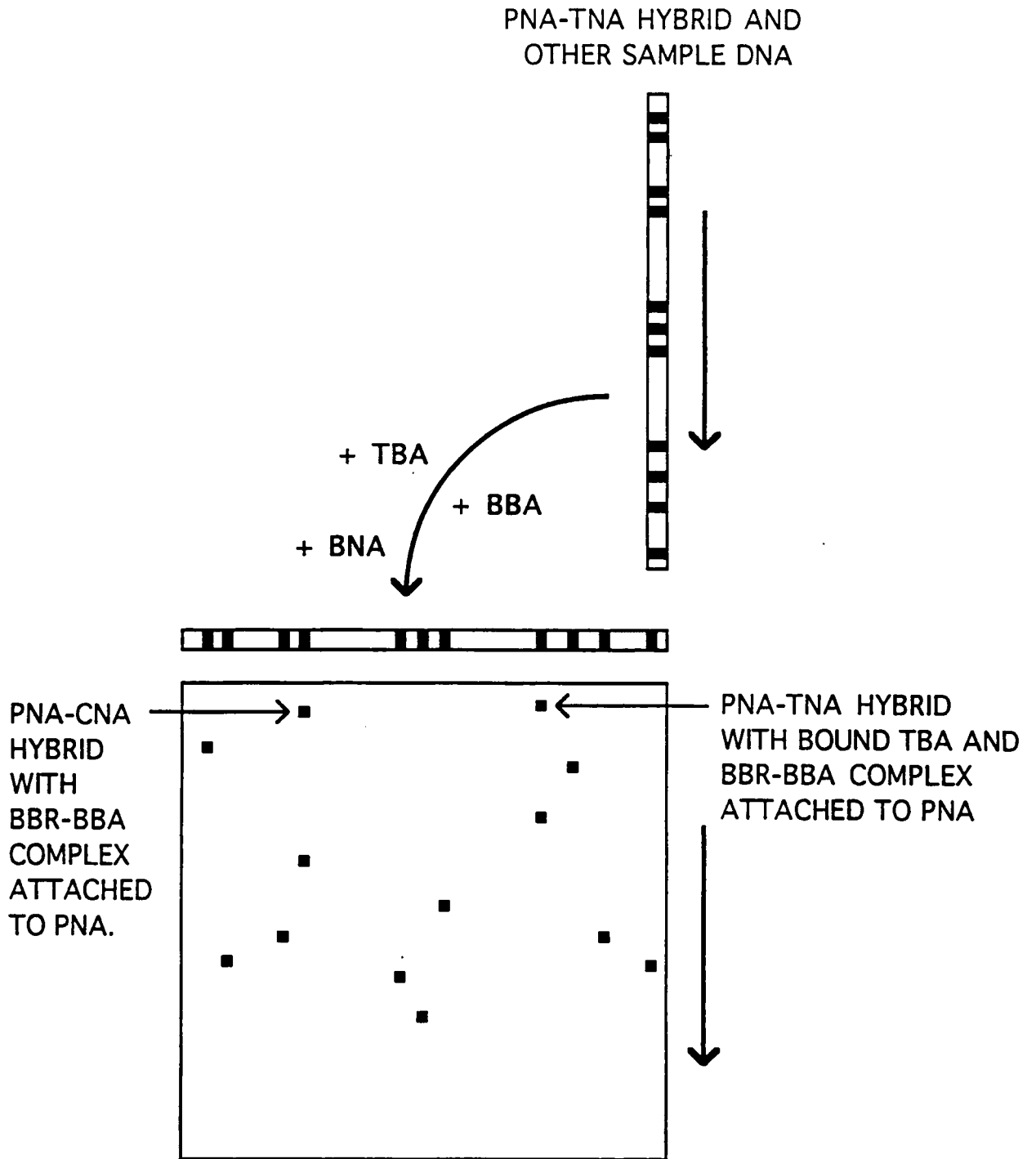

FIGURE 12B

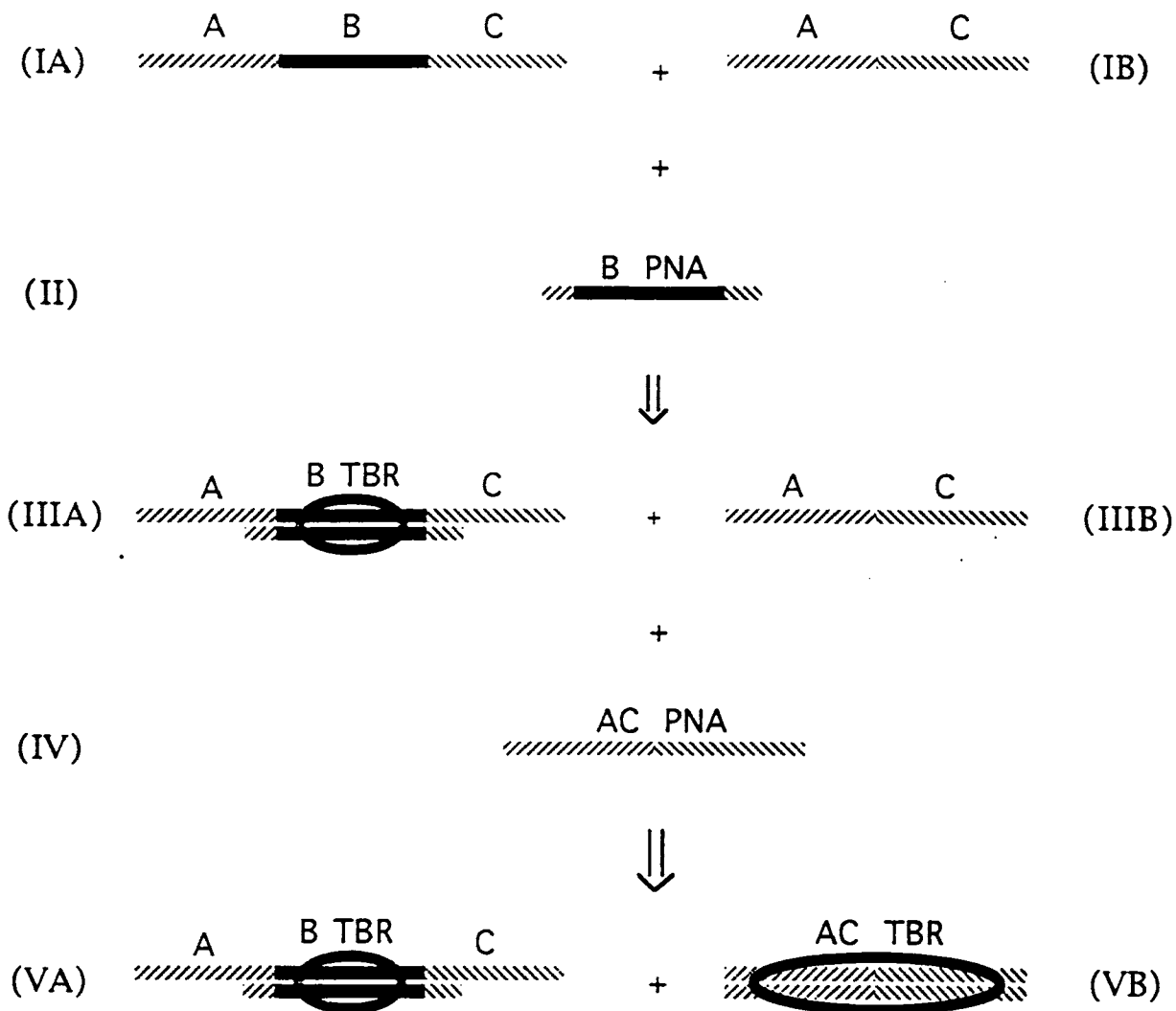

FIGURE 13

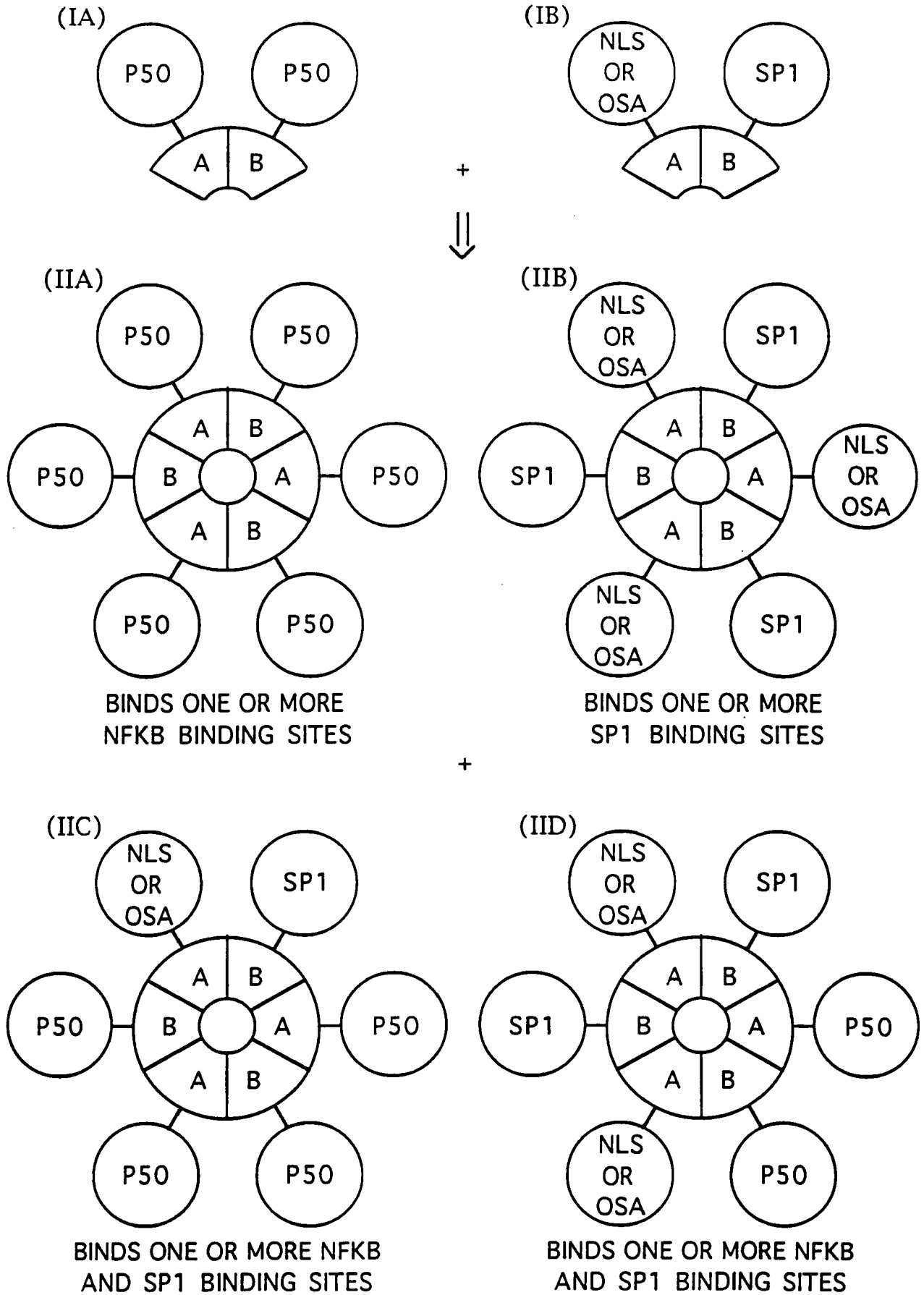

FIGURE 14

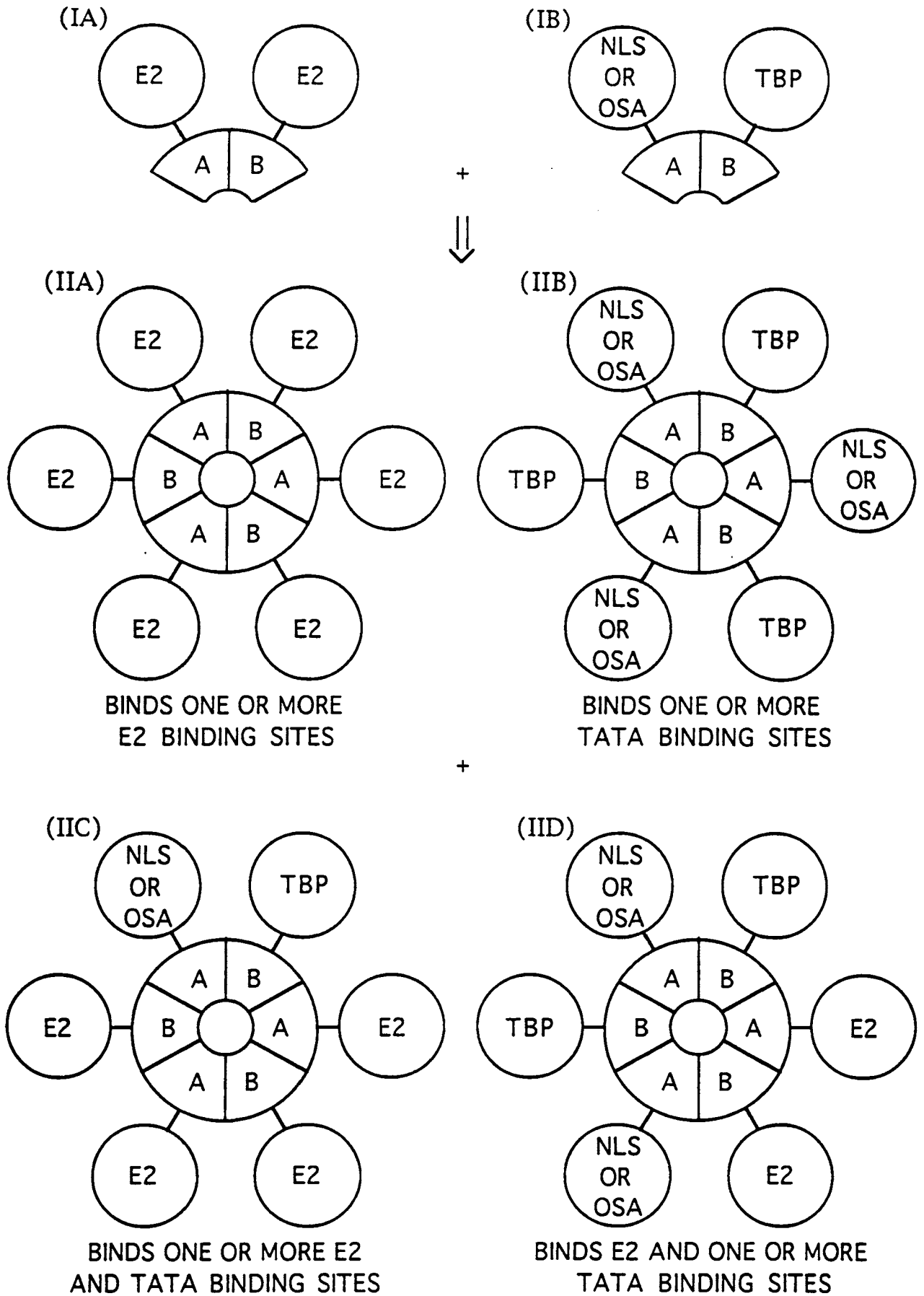

FIGURE 15

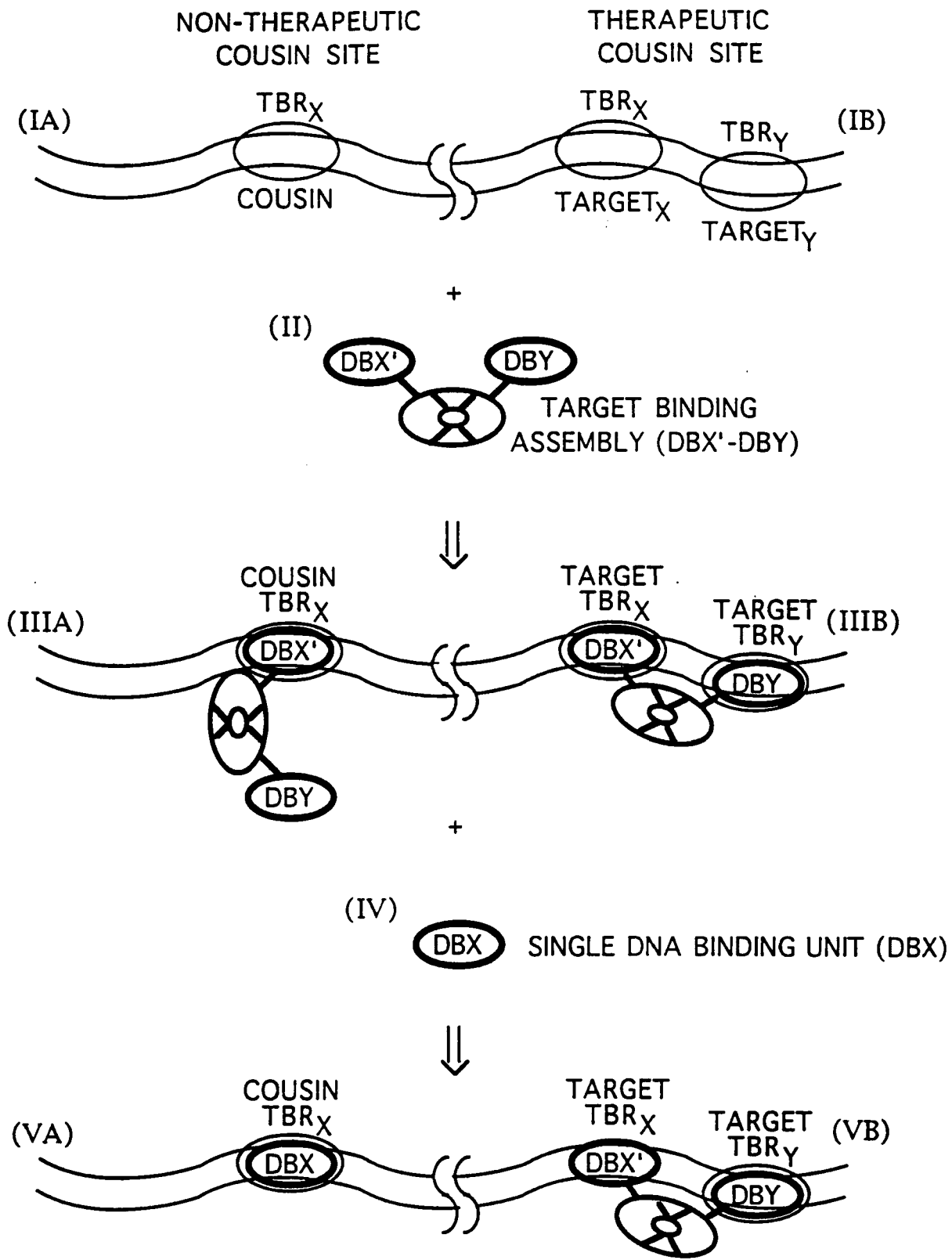

FIGURE 16

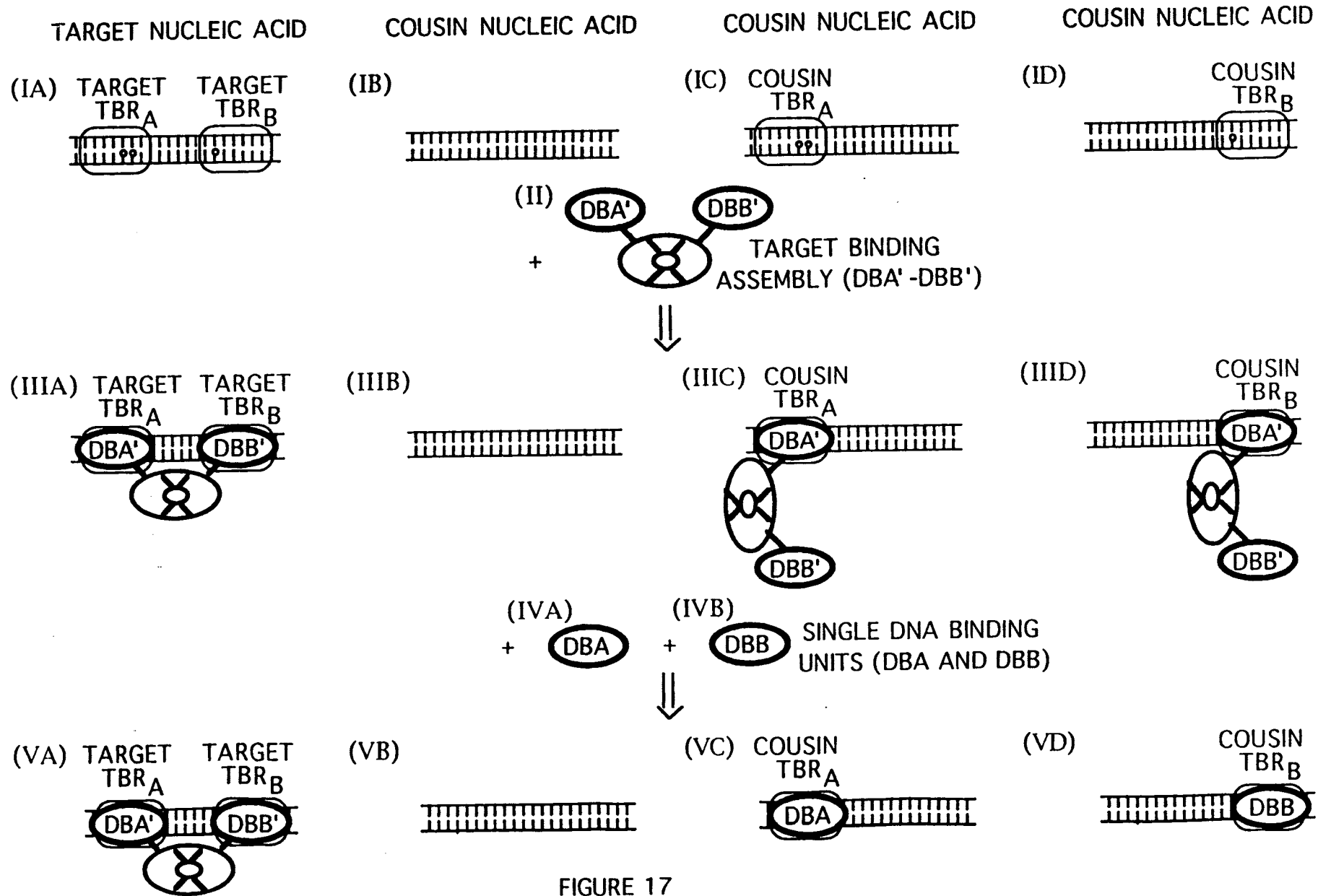

FIGURE 17

970 2681 -9

31 JUL 1997